



Features

- Low power consumption
- Low voltage drop
- Low temperature coefficient
- High input voltage (up to 37V)
- Output voltage accuracy: tolerance $\pm 2\%$
- TO92、SOT23-3 and SOT89 package

Applications

- Battery-powered equipment
- Communication equipment
- Audio/Video equipment

General Description

The TX75XXS series is a set of three-terminal low power high voltage regulators implemented in CMOS technology. They allow input voltages as high as 37V. They are available with several fixed output voltages ranging from 3.0V to 5.0V. CMOS technology ensures low voltage drop and low quiescent current. Although designed primarily as fixed voltage regulators, these devices can be used with external components to obtain variable voltages and currents.

Selection Table

Part No.	Output Voltage	Package	Marking
TX7530Sxx	3.0V	TO92 SOT89	75XX-H#(for TO92) 75XX-H#(for SOT89) XX-H(for SOT23-3)
TX7533Sxx	3.3V		
TX7536Sxx	3.6V		
TX7544Sxx	4.4V		
TX7550Sxx	5.0V		

Note:"xx" stands for package and RoHS.

TO92 & SOT89 packages will add a "#" mark at the end of the marking.

Order Information

TX75①②③④⑤

Designator	Symbol	Description
① ②	Integer	Output Voltage(3.0~5.0V)
③	S	Standard
④	T	Package:TO-92
	P	Package:SOT89
	M	Package:SOT23-3
⑤	R	RoHS / Pb Free
	G	Halogen Free



Block Diagram

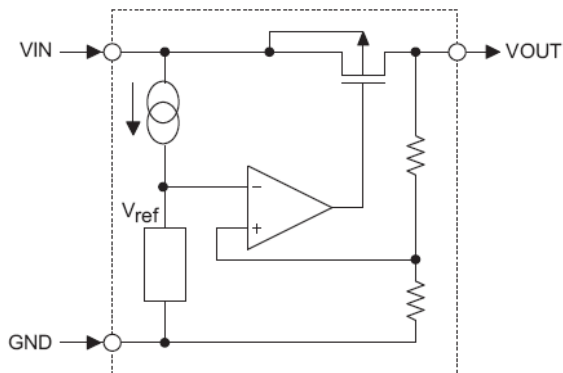

Pin Assignment

TO92 (Front view)



GND VIN VOUT

SOT89 (Top view)



GND VIN VOUT

SOT23-3 (Top view)

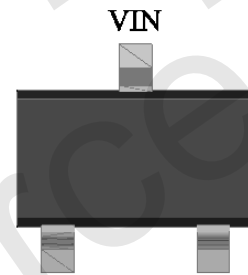

GND VOUT

Absolute Maximum Ratings

Supply Voltage-0.3V to 37V Storage Temperature-50°C to 125°C
Operating Temperature-40°C to 85°C

Note: These are stress ratings only. Stresses exceeding the range specified under “Absolute Maximum Ratings” may cause substantial damage to the device. Functional operation of this device at other conditions beyond those listed in the specification is not implied and prolonged exposure to extreme conditions may affect device reliability.

Thermal Information

Symbol	Parameter	Package	Max.	Unit
θ_{JA}	Thermal Resistance (Junction to Ambient) (Assume no ambient airflow, no heat sink)	SOT23	500	°C/W
		TO92	200	°C/W
		SOT89	200	°C/W
P_D	Power Dissipation	SOT23	0.20	W
		TO92	0.50	W
		SOT89	0.50	W

Note: P_D is measured at $T_a = 25^\circ\text{C}$



Electrical Characteristics

TX7530Sxx, +3.0V Output Type

Symbol	Parameter	Test Conditions		Min.	Typ.	Max.	Unit
		V _{IN}	Conditions				
V _{OUT}	Output Voltage	8V	I _{OUT} =10mA	2.94	3.00	3.06	V
I _{OUT}	Output Current	6V	-	-	200	-	mA
ΔV _{OUT}	Load Regulation	8V	1mA ≤ I _{OUT} ≤ 20mA	-	40	60	mV
V _{DIF}	Voltage Drop(Note)	-	I _{OUT} =1mA, ΔV _{OUT} =2%	-	10	-	mV
ISS	Current Consumption	8V	No load	-	2.0	5.0	μA
$\frac{\Delta V_{OUT}}{\Delta V_{IN} \times V_{OUT}}$	Line Regulation	-	4V ≤ V _{IN} ≤ 37V I _{OUT} =1mA	-	0.3	-	%/V
V _{IN}	Input Voltage	-	-	-	-	35	V
$\frac{\Delta V_{OUT}}{\Delta T_a}$	Temperature Coefficient	8V	I _{OUT} =10mA 0°C < T _a < 100°C	-	±0.12	-	mV/°C

Note: Dropout voltage is defined as the input voltage minus the output voltage that produces a 2% change in the output voltage from the value at V_{IN} = V_{OUT}+2V with a fixed load.

TX7533Sxx, +3.3V Output Type

Symbol	Parameter	Test Conditions		Min.	Typ.	Max.	Unit
		V _{IN}	Conditions				
V _{OUT}	Output Voltage	8V	I _{OUT} =10mA	3.234	3.300	3.366	V
I _{OUT}	Output Current	6.3V	-	-	200	-	mA
ΔV _{OUT}	Load Regulation	8V	1mA ≤ I _{OUT} ≤ 20mA	-	40	60	mV
V _{DIF}	Voltage Drop(Note)	-	I _{OUT} =1mA, ΔV _{OUT} =2%	-	10	-	mV
ISS	Current Consumption	8V	No load	-	2.0	5.0	μA
$\frac{\Delta V_{OUT}}{\Delta V_{IN} \times V_{OUT}}$	Line Regulation	-	4.5V ≤ V _{IN} ≤ 37V I _{OUT} =1mA	-	0.3	-	%/V
V _{IN}	Input Voltage	-	-	-	-	35	V
$\frac{\Delta V_{OUT}}{\Delta T_a}$	Temperature Coefficient	8V	I _{OUT} =10mA 0°C < T _a < 100°C	-	±0.12	-	mV/°C

Note: Dropout voltage is defined as the input voltage minus the output voltage that produces a 2% change in the output voltage from the value at V_{IN} = V_{OUT}+2V with a fixed load.



TX7536Sxx, +3.6V Output Type

Symbol	Parameter	Test Conditions		Min.	Typ.	Max.	Unit
		V _{IN}	Conditions				
V _{OUT}	Output Voltage	8V	I _{OUT} =10mA	3.528	3.600	3.672	V
I _{OUT}	Output Current	6.6V	-	-	200	-	mA
ΔV _{OUT}	Load Regulation	8V	1mA ≤ I _{OUT} ≤ 20mA	-	40	60	mV
V _{DIF}	Voltage Drop(Note)	-	I _{OUT} =1mA, ΔV _{OUT} =2%	-	10	-	mV
ISS	Current Consumption	8V	No load	-	2.0	5.0	μA
$\frac{\Delta V_{OUT}}{\Delta V_{IN} \times V_{OUT}}$	Line Regulation	-	4.6V ≤ V _{IN} ≤ 37V I _{OUT} =1mA	-	0.3	-	%/V
V _{IN}	Input Voltage	-	-	-	-	35	V
$\frac{\Delta V_{OUT}}{\Delta T_a}$	Temperature Coefficient	8V	I _{OUT} =10mA 0°C < T _a < 100°C	-	±0.12	-	mV/°C

Note: Dropout voltage is defined as the input voltage minus the output voltage that produces a 2% change in the output voltage from the value at V_{IN} = V_{OUT}+2V with a fixed load.

TX7544Sxx, +4.4V Output Type

Symbol	Parameter	Test Conditions		Min.	Typ.	Max.	Unit
		V _{IN}	Conditions				
V _{OUT}	Output Voltage	8V	I _{OUT} =10mA	4.312	4.400	4.488	V
I _{OUT}	Output Current	7.4V	-	-	200	-	mA
ΔV _{OUT}	Load Regulation	8V	1mA ≤ I _{OUT} ≤ 20mA	-	40	60	mV
V _{DIF}	Voltage Drop(Note)	-	I _{OUT} =1mA, ΔV _{OUT} =2%	-	10	-	mV
ISS	Current Consumption	8V	No load	-	2.0	5.0	μA
$\frac{\Delta V_{OUT}}{\Delta V_{IN} \times V_{OUT}}$	Line Regulation	-	5.4V ≤ V _{IN} ≤ 38V I _{OUT} =1mA	-	0.3	-	%/V
V _{IN}	Input Voltage	-	-	-	-	36	V
$\frac{\Delta V_{OUT}}{\Delta T_a}$	Temperature Coefficient	8V	I _{OUT} =10mA 0°C < T _a < 100°C	-	±0.12	-	mV/°C

Note: Dropout voltage is defined as the input voltage minus the output voltage that produces a 2% change in the output voltage from the value at V_{IN} = V_{OUT}+2V with a fixed load.



TX7550Sxx, +5.0V Output Type

Symbol	Parameter	Test Conditions		Min.	Typ.	Max.	Unit
		V _{IN}	Conditions				
V _{OUT}	Output Voltage	8V	I _{OUT} =10mA	4.90	5.00	5.10	V
I _{OUT}	Output Current	8V	-	-	200	-	mA
ΔV _{OUT}	Load Regulation	8V	1mA ≤ I _{OUT} ≤ 20mA	-	40	60	mV
V _{DIF}	Voltage Drop(Note)	-	I _{OUT} =1mA, ΔV _{OUT} =2%	-	10	-	mV
ISS	Current Consumption	8V	No load	-	2.0	5.0	μA
$\frac{\Delta V_{OUT}}{\Delta V_{IN} \times V_{OUT}}$	Line Regulation	-	6V ≤ V _{IN} ≤ 39V I _{OUT} =1mA	-	0.3	-	%/V
V _{IN}	Input Voltage	-	-	-	-	36	V
$\frac{\Delta V_{OUT}}{\Delta T_a}$	Temperature Coefficient	8V	I _{OUT} =10mA 0°C < T _a < 100°C	-	±0.12	-	mV/°C

Note: Dropout voltage is defined as the input voltage minus the output voltage that produces a 2% change in the output voltage from the value at V_{IN} = V_{OUT}+2V with a fixed load.

Application Circuits

Basic Circuits

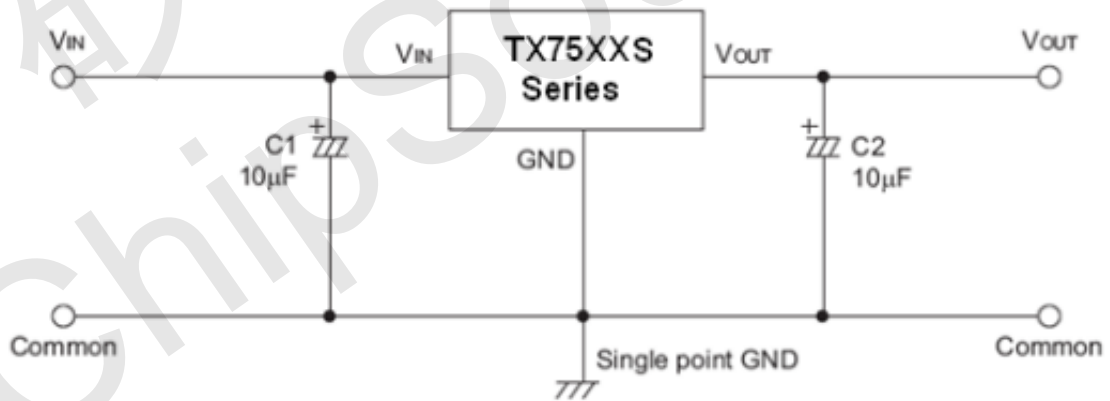



Package Information

3-pin SOT23-3 Outline Dimensions

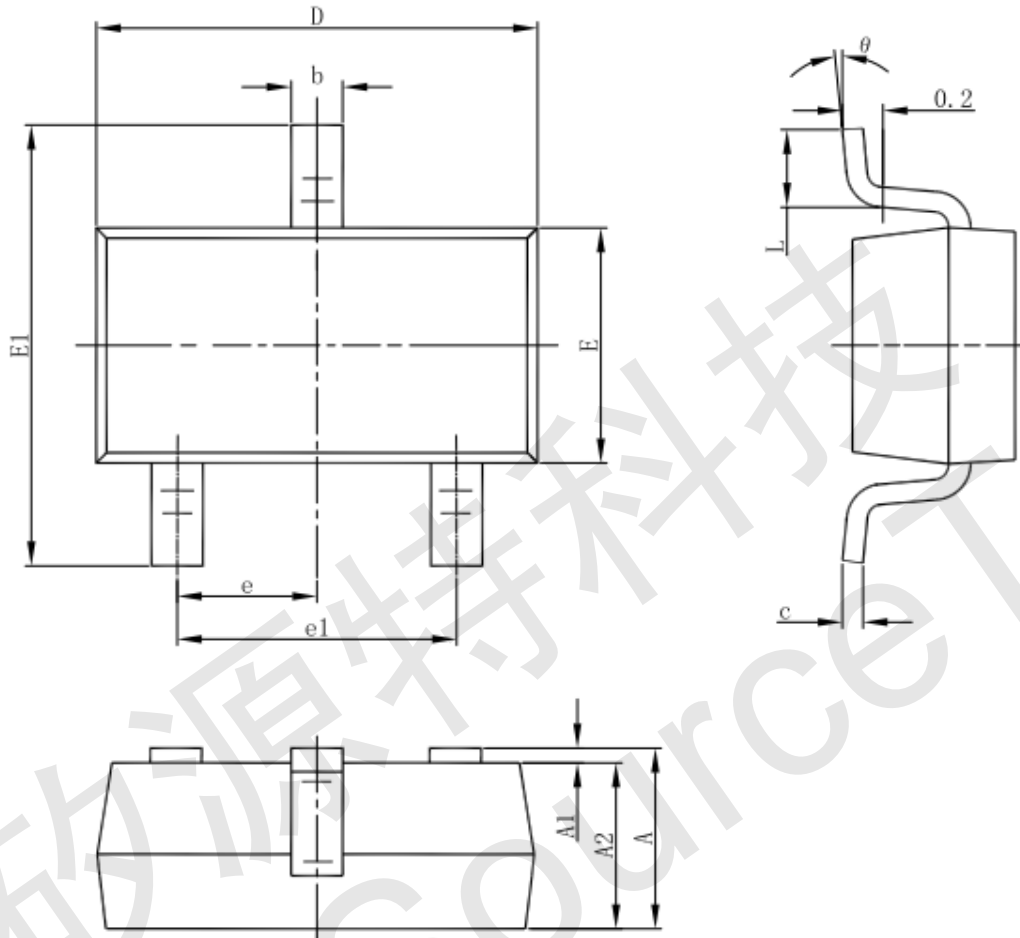

Symbol	Dimensions In Millimeters		Dimensions In Inches	
	Min	Max	Min	Max
A	1.050	1.250	0.041	0.049
A1	0.000	0.100	0.000	0.004
A2	1.050	1.150	0.041	0.045
b	0.300	0.500	0.012	0.020
c	0.100	0.200	0.004	0.008
D	2.820	3.020	0.111	0.119
E	1.500	1.700	0.059	0.067
E1	2.650	2.950	0.104	0.116
e	0.950(BSC)		0.037(BSC)	
e1	1.800	2.000	0.071	0.079
L	0.300	0.600	0.012	0.024
θ	0°	8°	0°	8°



3-pin TO92 Outline Dimensions

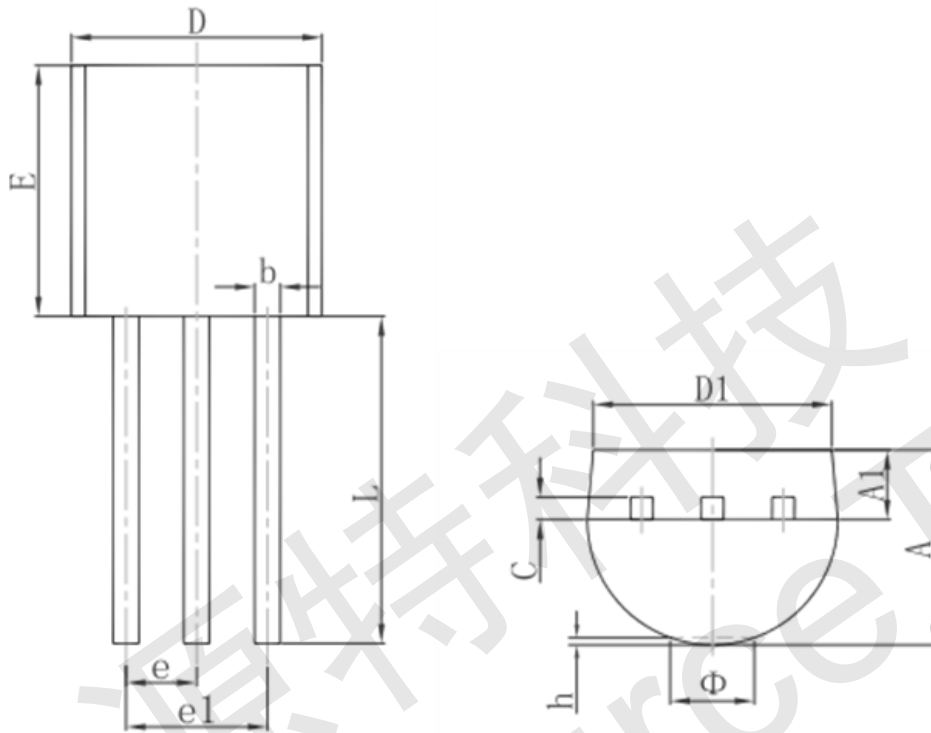

Symbol	Dimensions In Millimeters		Dimensions In Inches	
	Min.	Max.	Min.	Max.
A	3.300	3.700	0.130	0.146
A1	1.100	1.400	0.043	0.055
b	0.380	0.550	0.015	0.022
c	0.360	0.510	0.014	0.020
D	4.300	4.700	0.169	0.185
D1	3.430		0.135	
E	4.300	4.700	0.169	0.185
e	1.270 TYP.		0.050 TYP.	
e1	2.440	2.640	0.096	0.104
L	14.100	14.500	0.555	0.571
Φ		1.600		0.063
h	0.000	0.380	0.000	0.015



3-pin SOT89 Outline Dimensions

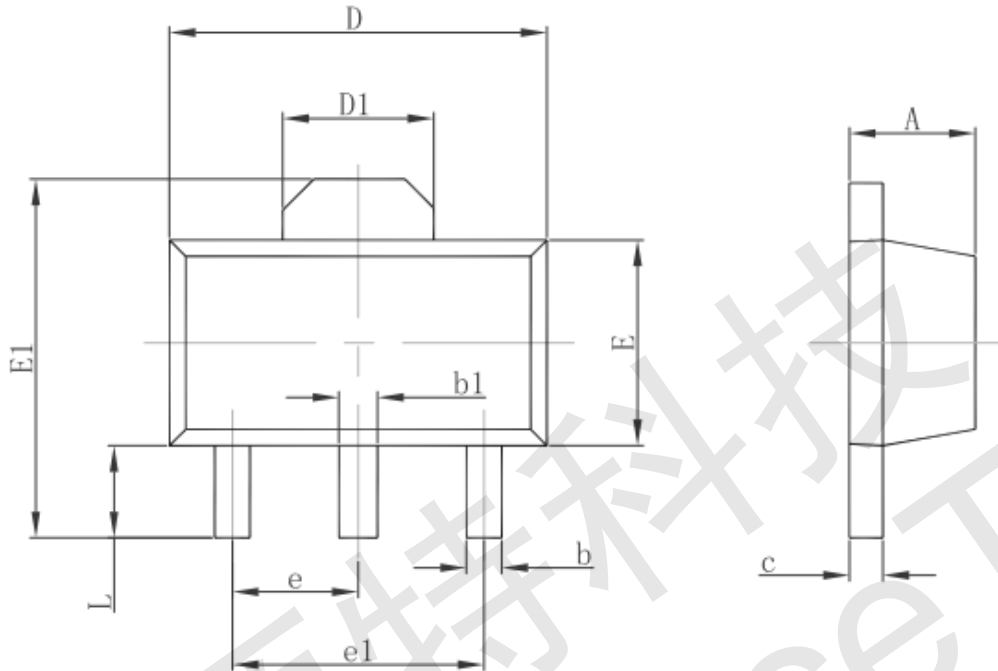

Symbol	Dimensions In Millimeters		Dimensions In Inches	
	Min.	Max.	Min.	Max.
A	1.400	1.600	0.055	0.063
b	0.320	0.520	0.013	0.020
b1	0.400	0.580	0.016	0.023
c	0.350	0.440	0.014	0.017
D	4.400	4.600	0.173	0.181
D1	1.550 REF.		0.061 REF.	
E	2.300	2.600	0.091	0.102
E1	3.940	4.250	0.155	0.167
e	1.500 TYP.		0.060 TYP.	
e1	3.000 TYP.		0.118 TYP.	
L	0.900	1.200	0.035	0.047



Product Tape and Reel Specifications
3-pin TO92 Reel Dimensions (Unit: mm)

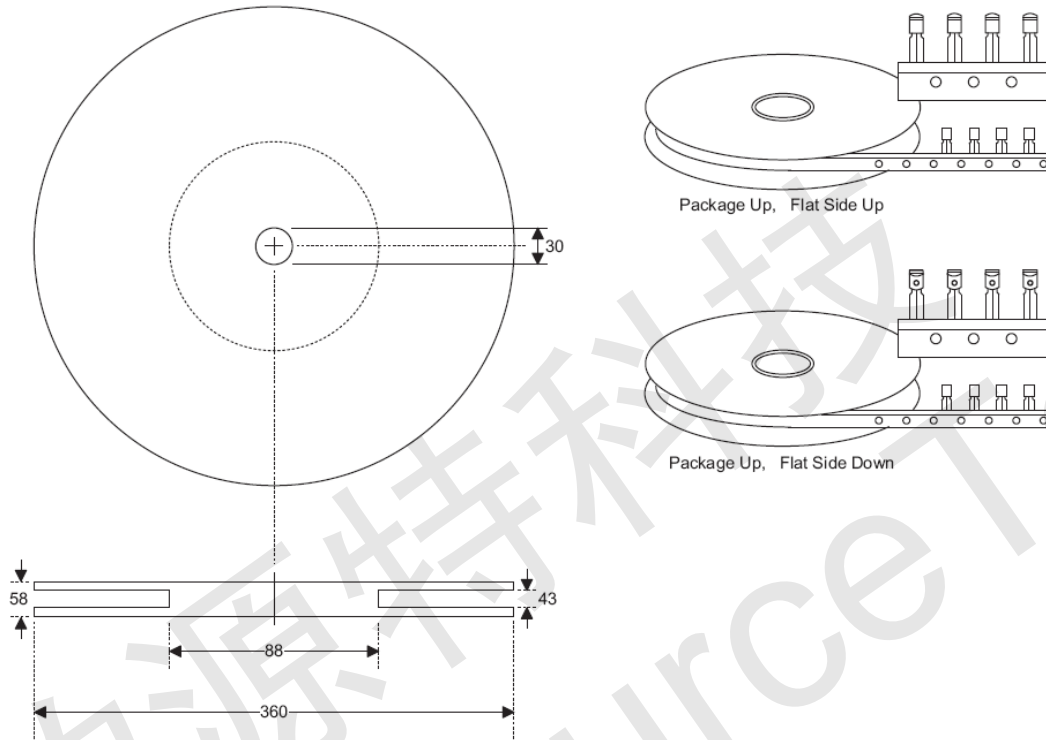



Reel Dimensions

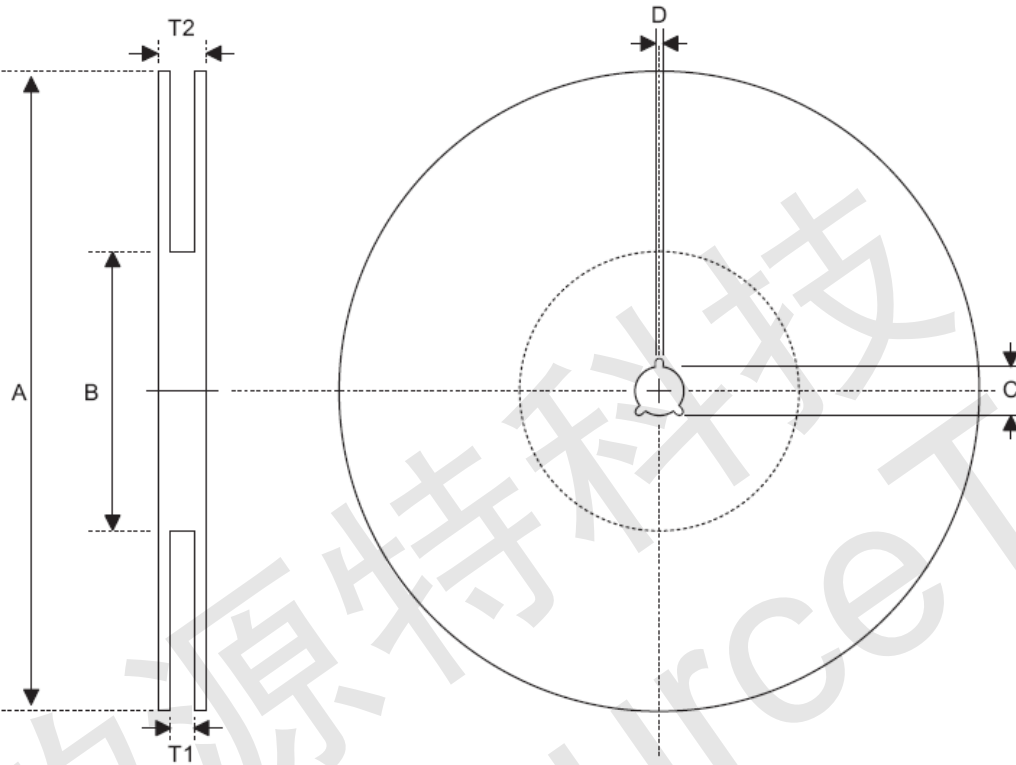

SOT89

Symbol	Description	Dimensions in mm
A	Reel Outer Diameter	180.0±1.0
B	Reel Inner Diameter	62.0±1.5
C	Spindle Hole Diameter	12.75 ^{+0.15/-0.00}
D	Key Slit Width	1.90±0.15
T1	Space Between Flange	12.4 ^{+0.2/-0.00}
T2	Reel Thickness	17.0 ^{+0.0/-0.4}

SOT23-5

Symbol	Description	Dimensions in mm
A	Reel Outer Diameter	178.0±1.0
B	Reel Inner Diameter	62.0±1.0
C	Spindle Hole Diameter	13.0±0.2
D	Key Slit Width	2.50±0.25
T1	Space Between Flange	8.4 ^{+1.5/-0.0}
T2	Reel Thickness	11.4 ^{+1.5/-0.0}



Carrier Tape Dimensions

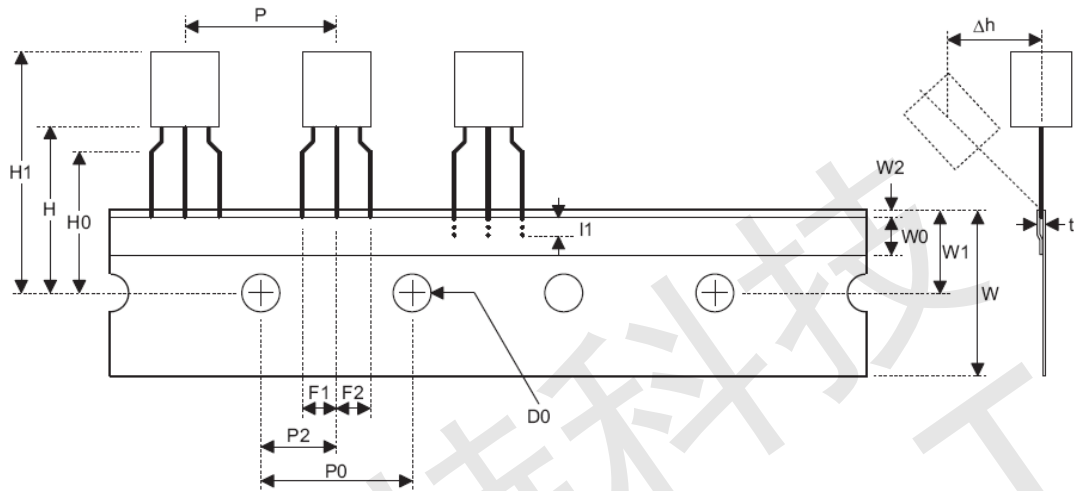

TO92

Symbol	Description	Dimensions in mm
I1	Taped Lead Length	(2.5)
P	Component Pitch	12.7±1.0
P ₀	Perforation Pitch	12.7±0.3
P ₂	Component to Perforation (Length Direction)	6.35±0.40
F ₁	Lead Spread	2.5 ^{+0.4/-0.1}
F ₂	Lead Spread	2.5 ^{+0.4/-0.1}
Δh	Component Alignment	0.0±0.1
W	Carrier Tape Width	18.0 ^{+1.0/-0.5}
W ₀	Hold-down Tape Width	6.0±0.5
W ₁	Perforation Position	9.0±0.5
W ₂	Hold-down Tape Position	(0.5)
H ₀	Lead Clinch Height	16.0±0.5
H ₁	Component Height	Less than 24.7
D ₀	Perforation Diameter	4.0±0.2
t	Taped Lead Thickness	0.7±0.2
H	Component Base Height	19.0±0.5

Note: Thickness less than 0.38_0.05mm~0.5mm

P₀ Accumulated pitch tolerance: _1mm/20pitches.

() Bracketed figures are for consultation only



Carrier Tape Dimensions

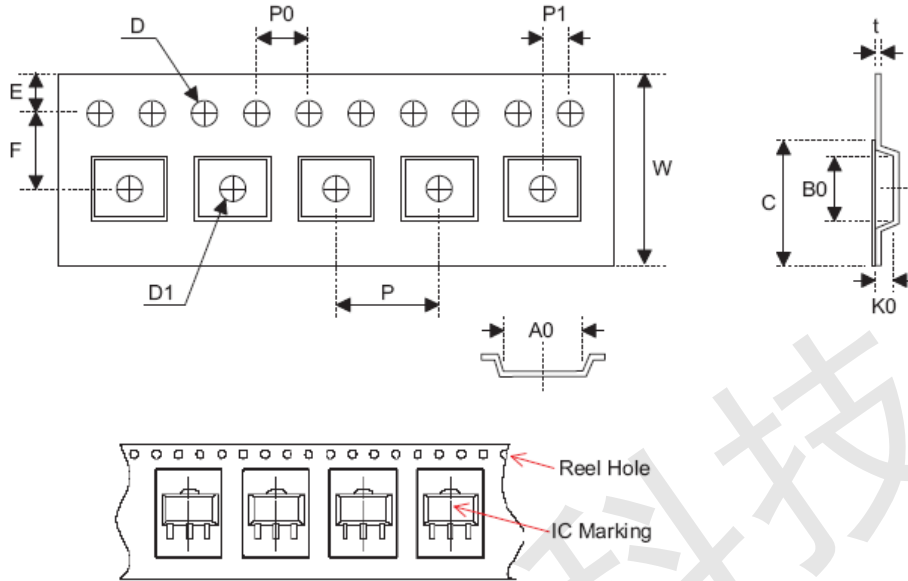

SOT89

Symbol	Description	Dimensions in mm
W	Carrier Tape Width	12.0 ^{+0.3/-0.1}
P	Cavity Pitch	8.0±0.1
E	Perforation Position	1.75±0.10
F	Cavity to Perforation (Width Direction)	5.50±0.05
D	Perforation Diameter	1.5 ^{+0.1/-0.0}
D1	Cavity Hole Diameter	1.5 ^{+0.1/-0.0}
P0	Perforation Pitch	4.0±0.1
P1	Cavity to Perforation (Length Direction)	2.0±0.1
A0	Cavity Length	4.8±0.1
B0	Cavity Width	4.5±0.1
K0	Cavity Depth	1.8±0.1
t	Carrier Tape Thickness	0.300±0.013
C	Cover Tape Width	9.3±0.1

SOT23-5

Symbol	Description	Dimensions in mm
W	Carrier Tape Width	8.0±0.3
P	Cavity Pitch	4.0±0.1
E	Perforation Position	1.75±0.10
F	Cavity to Perforation (Width Direction)	3.50±0.05
D	Perforation Diameter	1.5 ^{+0.1/-0.0}
D1	Cavity Hole Diameter	1.5 ^{+0.1/-0.0}
P0	Perforation Pitch	4.0±0.1
P1	Cavity to Perforation (Length Direction)	2.00±0.05
A0	Cavity Length	3.15±0.10
B0	Cavity Width	3.2±0.1
K0	Cavity Depth	1.4±0.1
t	Carrier Tape Thickness	0.20±0.03
C	Cover Tape Width	5.3±0.1



© ShenZhen ChipSourceTek Technology Co. ,Ltd.

ChipSourceTek cannot assume responsibility for use of any circuitry other than circuitry entirely embodied in a ChipSourceTek product. No circuit patent license, copyrights or other intellectual property rights are implied. ChipSourceTek reserves the right to make changes to their products or specifications without notice. Customers are advised to obtain the latest version of relevant information to verify, before placing orders, that information being relied on is current and complete.

矽源特科技
ChipSourceTek