



**N-Channel Enhancement Mode Power MOSFET**

**Description**

The MX3400A uses advanced trench technology to provide excellent  $R_{DS(ON)}$ , low gate charge and operation with gate voltages as low as 2.5V.

This device is suitable for use as a load switch or in PWM applications.

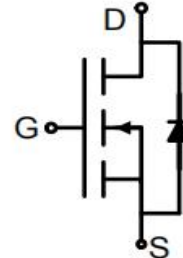

**General Features**

- ◆  $V_{DS} = 30V$ ,  $I_D = 5.8A$
- ◆  $R_{DS(ON)}$  (Typ.)  $22m\Omega$  @  $V_{GS} = 10V$
- ◆  $R_{DS(ON)}$  (Typ.)  $25m\Omega$  @  $V_{GS} = 4.5V$
- ◆  $R_{DS(ON)}$  (Typ.)  $30m\Omega$  @  $V_{GS} = 2.5V$
- ◆ High power and current handling capability
- ◆ Lead free product is acquired
- ◆ Surface mount package

**Application**

- ◆ PWM applications
- ◆ Load switch

**Schematic diagram**

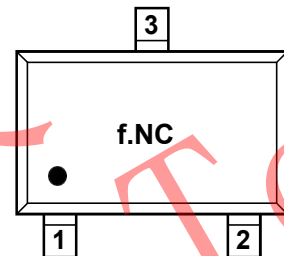

**Marking and pin assignment**



SOT-23 (TOP VIEW)

**Absolute Maximum Ratings** ( $T_A = 25^\circ C$  unless otherwise noted)

parameter	symbol	limit	unit
Drain-source voltage	$V_{DS}$	30	V
Gate-source voltage	$V_{GS}$	$\pm 12$	V
Drain current-continuous <sup>a</sup> @ $T_j = 125^\circ C$ -pulse <sup>b</sup>	$I_D$	5.8	A
	$I_{DM}$	25	A
Maximum power dissipation	$P_D$	1.4	W
Operating junction Temperature range	$T_j$	-55—150	$^\circ C$



**Electrical Characteristics** (TA=25°C unless otherwise noted)

Symbol	Parameter	Conditions	Min	Typ	Max	Unit
<b>On/Off States</b>						
BV <sub>DSS</sub>	Drain-Source Breakdown Voltage	V <sub>GS</sub> =0V, I <sub>D</sub> =250μA	30	33		V
I <sub>DSS</sub>	Zero Gate Voltage Drain Current	V <sub>DS</sub> =30V, V <sub>GS</sub> =0V			1	μA
I <sub>GSS</sub>	Gate-Body Leakage Current	V <sub>GS</sub> =±12V, V <sub>DS</sub> =0V			±100	nA
V <sub>GS(th)</sub>	Gate Threshold Voltage	V <sub>DS</sub> =V <sub>GS</sub> , I <sub>D</sub> =250μA	0.7	0.9	1.4	V
g <sub>FS</sub>	Forward Transconductance	V <sub>DS</sub> =5V, I <sub>D</sub> =2.9A	10			S
R <sub>DS(ON)</sub>	Drain-Source On-State Resistance	V <sub>GS</sub> =10V, I <sub>D</sub> =5.5A		22	35	mΩ
		V <sub>GS</sub> =4.5V, I <sub>D</sub> =4.5A		25	40	mΩ
		V <sub>GS</sub> =2.5V, I <sub>D</sub> =4A		30	55	mΩ
<b>Dynamic Characteristics</b>						
C <sub>iss</sub>	Input Capacitance			623		pF
C <sub>oss</sub>	Output Capacitance	V <sub>DS</sub> =15V, V <sub>GS</sub> =0V, f=1.0MHz		99		pF
C <sub>rss</sub>	Reverse Transfer Capacitance			77		pF
<b>Switching Times</b>						
t <sub>d(on)</sub>	Turn-on Delay Time			3.3		nS
t <sub>r</sub>	Turn-on Rise Time			4.8		nS
t <sub>d(off)</sub>	Turn-Off Delay Time	V <sub>DD</sub> =15V, I <sub>D</sub> =2.9A, V <sub>GS</sub> =10V, R <sub>G</sub> =3Ω		26		nS
t <sub>f</sub>	Turn-Off Fall Time			4		nS
Q <sub>g</sub>	Total Gate Charge			9.5		nC
Q <sub>gs</sub>	Gate-Source Charge	V <sub>DS</sub> =15V, I <sub>D</sub> =5.8A, V <sub>GS</sub> =4.5V		1.5		nC
Q <sub>gd</sub>	Gate-Drain Charge			3		nC
<b>Source-Drain Diode Characteristics</b>						
I <sub>SD</sub>	Source-Drain Current(Body Diode)				2.9	A
V <sub>SD</sub>	Forward on Voltag (Note 1)	V <sub>GS</sub> =0V, I <sub>S</sub> =2.9A		0.75	1.2	V

Notes:

- 1.Repetitive Rating: Pulse width limited by maximum junction temperature.
- 2.surface mounted on FR4 board,t≤10sec
- 3.pulse test: pulse width≤300μs,duty≤2%
- 4.guaranteed by design, not subject to production testing



**Typical Performance Characteristics**

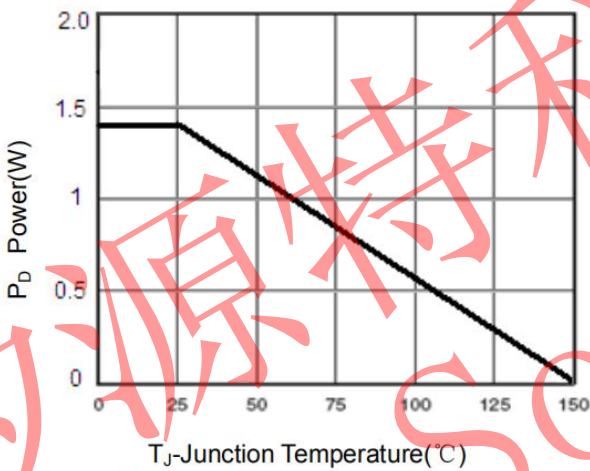
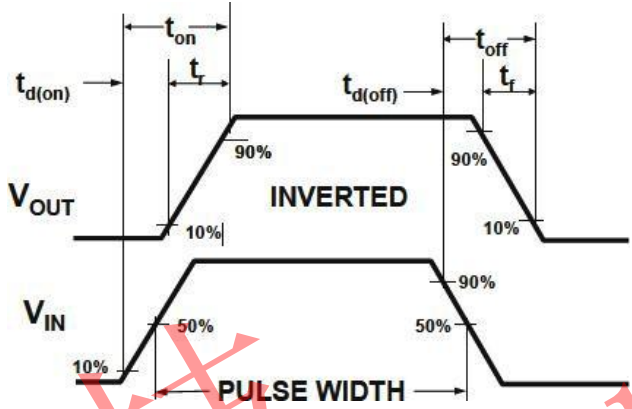
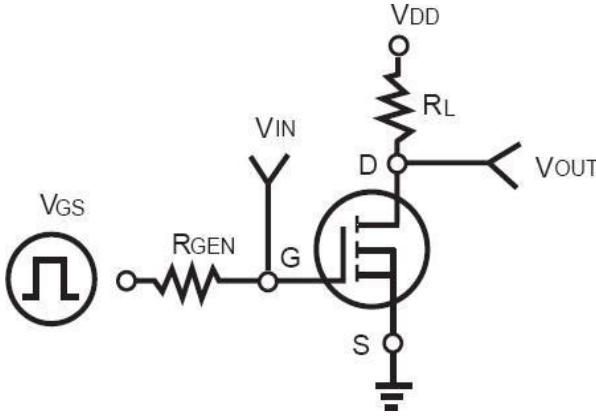

**Figure 3 Power Dissipation**

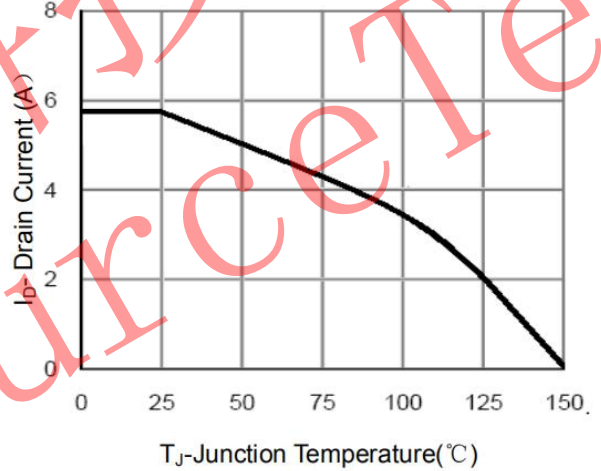

**Figure 4 Drain Current**

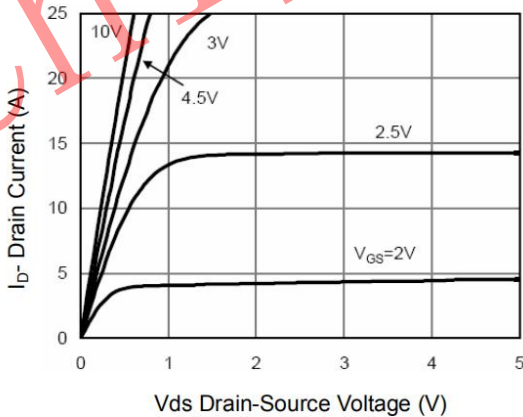

**Figure 5 Output Characteristics**

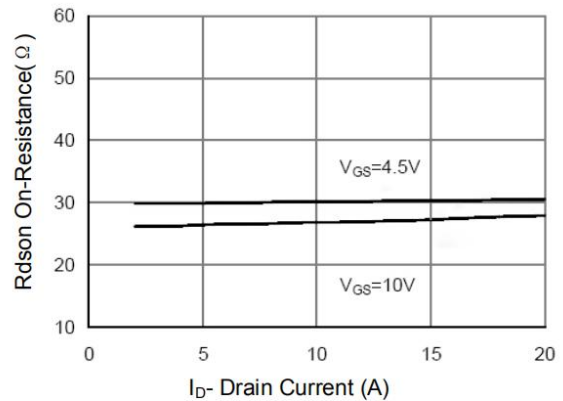

**Figure 6 Drain-Source On-Resistance**

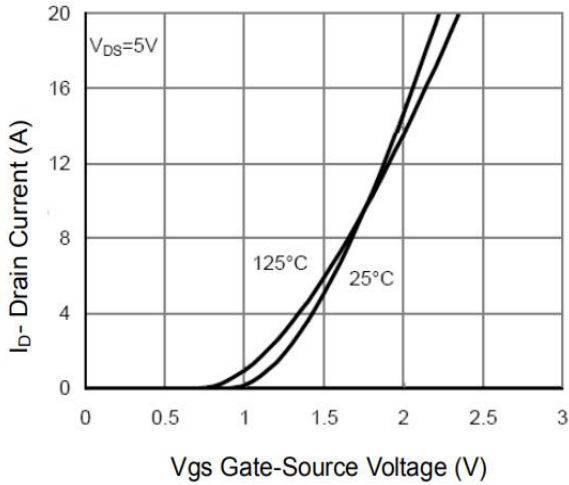

Figure 7 Transfer Characteristics

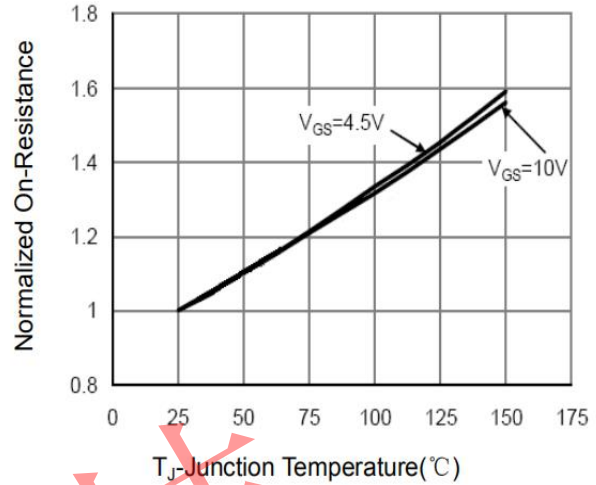

Figure 8 Drain-Source On-Resistance

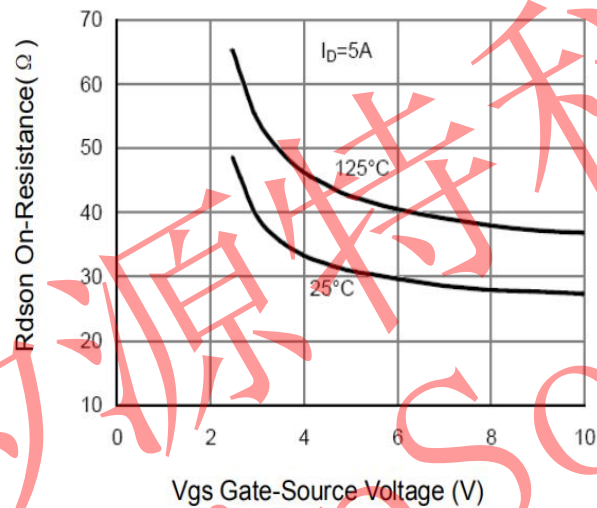

Figure 9 Rdson vs Vgs

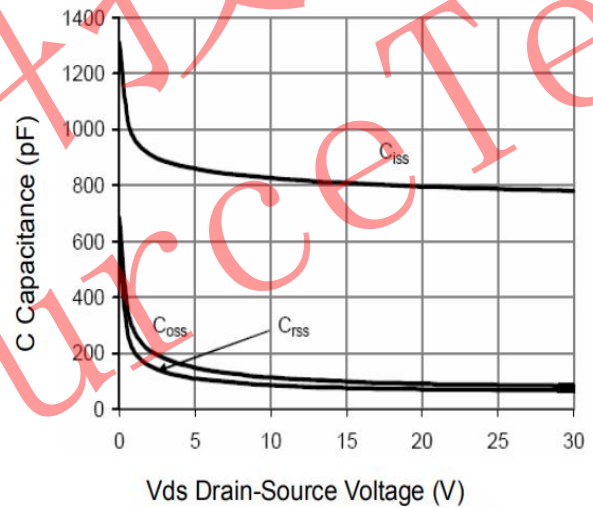

Figure 10 Capacitance vs Vds

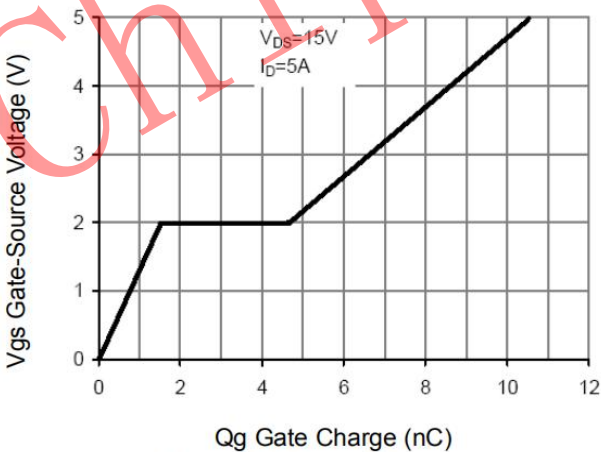

Figure 11 Gate Charge

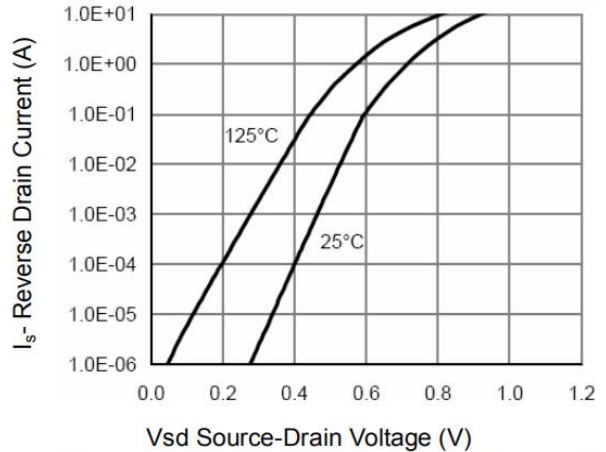

Figure 12 Source-Drain Diode Forward

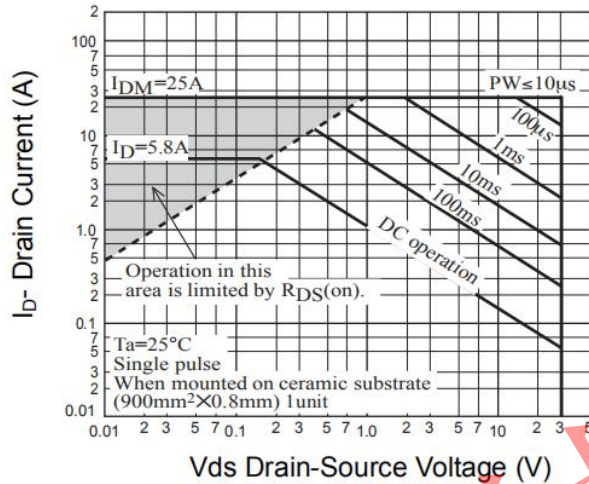

Figure 13 Safe Operation Area

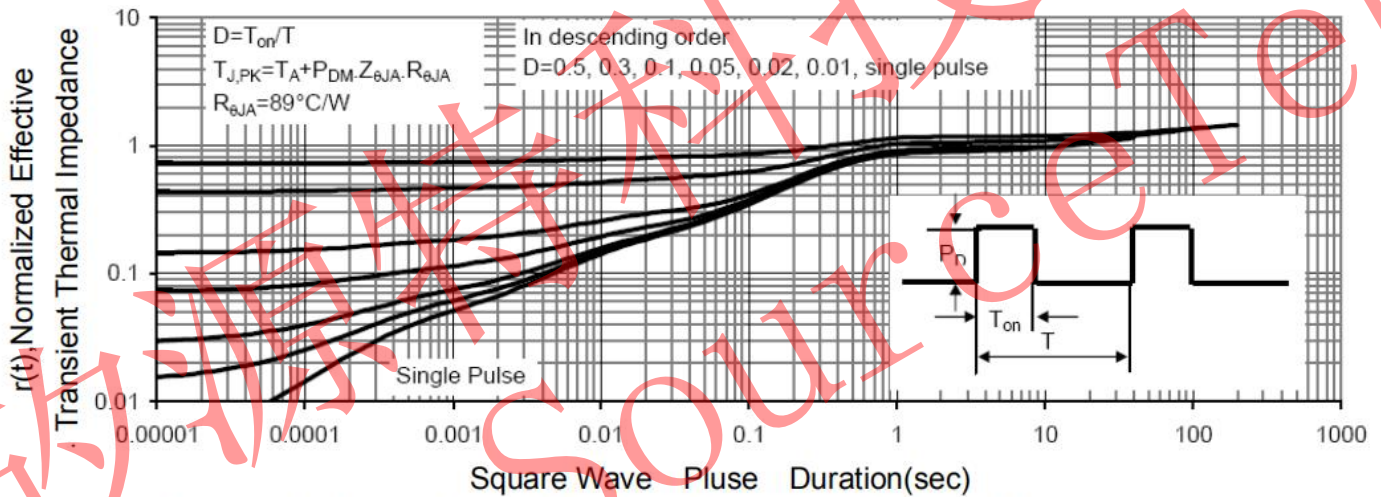
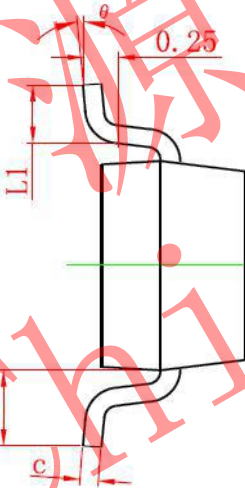
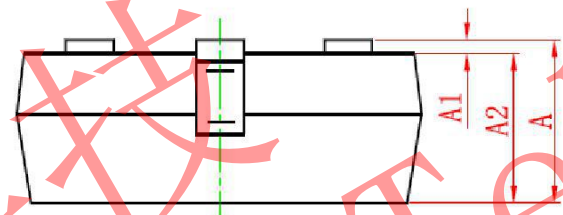
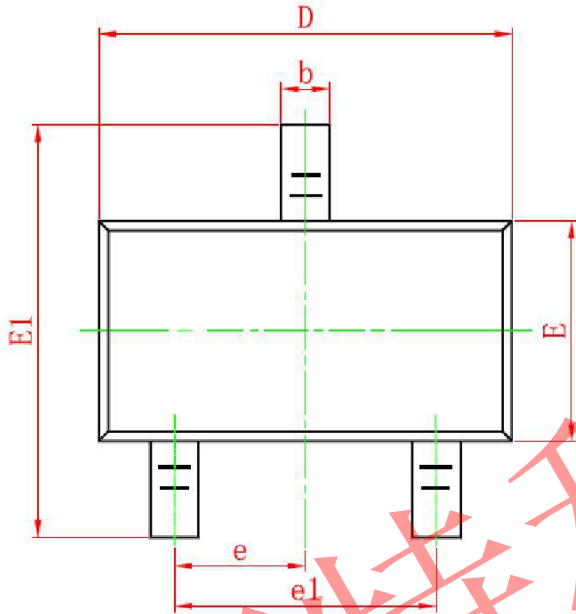

Figure 14 Normalized Maximum Transient Thermal Impedance



## SOT-23 PACKAGE INFORMATION

Dimensions in Millimeters (UNIT:mm)



Symbol	Dimensions in Millimeters	
	MIN.	MAX.
A	0.900	1.150
A1	0.000	0.100
A2	0.900	1.050
b	0.300	0.500
c	0.080	0.150
D	2.800	3.000
E	1.200	1.400
E1	2.250	2.550
e	0.950TYP	
e1	1.800	2.000
L	0.550REF	
L1	0.300	0.500
$\theta$	0°	8°