



N-Channel Enhancement Mode Power MOSFET

Description

The MX2302A uses advanced trench technology to provide excellent $R_{DS(ON)}$, low gate charge and operation with gate voltages as low as 2.5V.

This device is suitable for use as a load switch or in PWM applications.

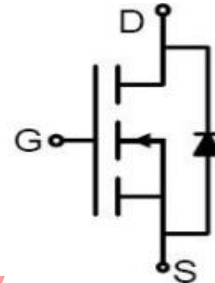

General Features

- ◆ $V_{DS} = 20V$, $I_D = 3.0A$
- ◆ @ $V_{GS} = 4.5V$ $R_{DS(ON)}$ (Typ.)=45m Ω
- ◆ @ $V_{GS} = 2.5V$ $R_{DS(ON)}$ (Typ.)=55m Ω
- ◆ High power and current handling capability
- ◆ Lead free product is acquired
- ◆ Surface mount package

Schematic

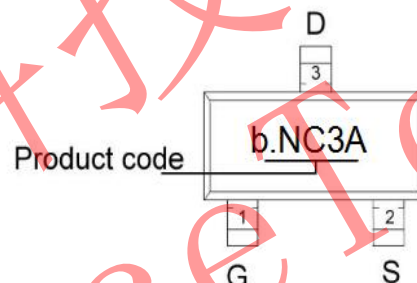

Application

- ◆ PWM applications
- ◆ Load switch
- ◆ Battery protection

Marking and pin assignment
SOT-23 (TOP VIEW)

Package

- ◆ SOT-23



Ordering Information

Part Number	Marking	Storage Temperature	Package	Devices Per Reel
MX2302A	b.NC3A	-55°C to +150°C	SOT-23	3000

Absolute Maximum Ratings (TA=25°C unless otherwise noted)

parameter	symbol	limit	unit
Drain-source voltage	V_{DS}	20	V
Gate-source voltage	V_{GS}	± 10	V
Drain current-continuous ^a @Tj=125°C -pulse ^b	I_D	3	A
	I_{DM}	10	A
Maximum power dissipation	P_D	1	W
Operating junction Temperature range	T_j	-55—125	°C



Electrical Characteristics (TA=25°C unless otherwise noted)

Parameter	Symbol	Condition	Min	Typ	Max	Unit
OFF Characteristics						
Drain-source breakdown voltage	BV_{DSS}	$V_{GS}=0V, I_D=250\mu A$	20	-	-	V
Zero gate voltage drain current	I_{DSS}	$V_{DS}=20V, V_{GS}=0V$	-	-	1	μA
Gate-body leakage	I_{GSS}	$V_{DS}=10V, V_{GS}=\pm 12V$	-	-	± 100	nA
ON Characteristics						
Gate threshold voltage	$V_{GS(th)}$	$V_{DS}=V_{GS}, I_D=-250\mu A$	0.5	0.7	1.0	V
Drain-Source On-State Resistance	$R_{DS(ON)}$	$V_{GS}=-2.5V, I_D=-2.5A$	-	45	55	m Ω
		$V_{GS}=-4.5V, I_D=-2.9A$	-	35	45	
Forward transconductance	g_{fs}	$V_{GS}=-5V, I_D=-2.9A$	-	8	-	S
Dynamic Characteristics						
Input capacitance	C_{ISS}	$V_{DS}=-10V, V_{GS}=0V$ $f=1.0MHz$	-	300	-	pF
Output capacitance	C_{OSS}		-	120	-	
Reverse transfer capacitance	C_{RSS}		-	80	-	
Switching Characteristics						
Turn-on delay time	$t_{D(ON)}$	$V_{DD}=-10V$ $I_D=-2.9A$ $V_{GEN}=-10V$ $R_{GEN}=60\Omega$	-	10	15	ns
Rise time	t_r		-	50	85	
Turn-off delay time	$t_{D(OFF)}$		-	17	45	
Fall time	t_f		-	10	20	
Total gate charge	Q_g	$V_{DS}=-10V, I_D=-2.9A$ $V_{GS}=-4.5V$	-	4	10	nC
Gate-source charge	Q_{gs}		-	0.65	-	
Gate-drain charge	Q_{gd}		-	1.2	-	
DRAIN-SOURCE DIODE CHARACTERISTICS						
Diode forward voltage	V_{SD}	$V_{GS}=0V, I_S=-2.9A$	-	0.75	1.2	V

Notes:

- surface mounted on FR4 board, $t \leq 10sec$
- pulse test: pulse width $\leq 300\mu s$, duty $\leq 2\%$
- guaranteed by design, not subject to production testing

Thermal Characteristics

Thermal Resistance junction-to ambient	$R_{th JA}$	125	$^{\circ}C/W$
--	-------------	-----	---------------



Typical Performance Characteristics

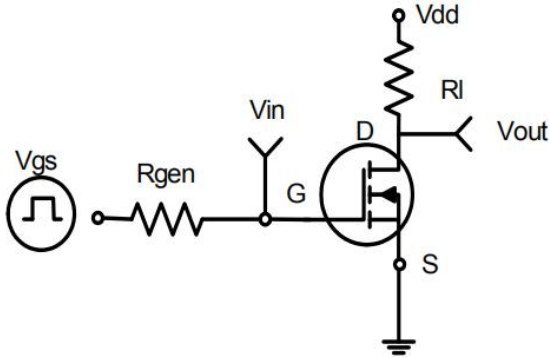

Figure 1: Switching Test Circuit

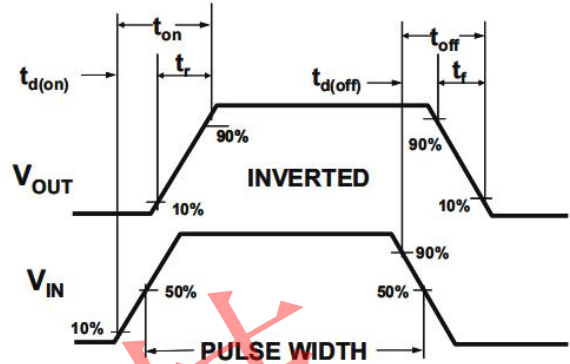

Figure 2: Switching Waveforms

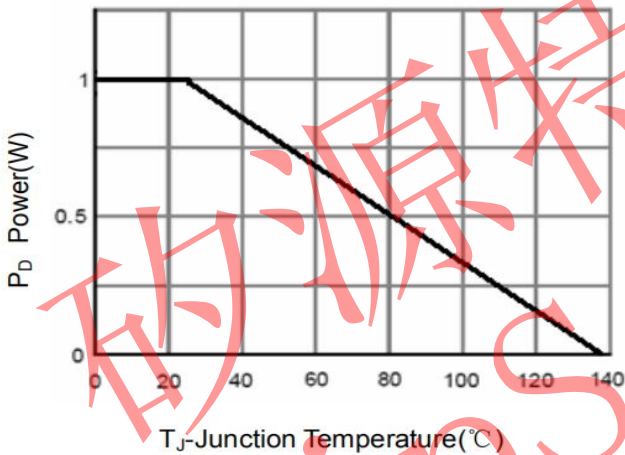

Figure 3 Power Dissipation

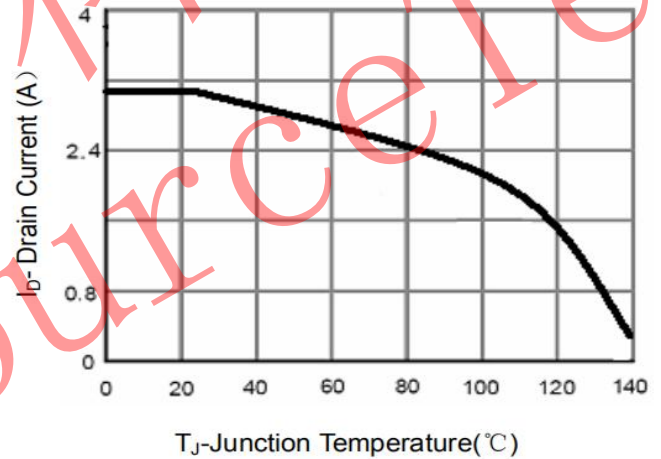

Figure 4 Drain Current

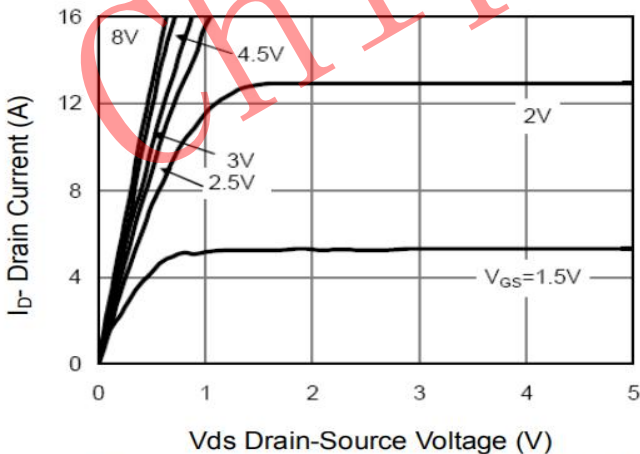

Figure 5 Output CHARACTERISTICS

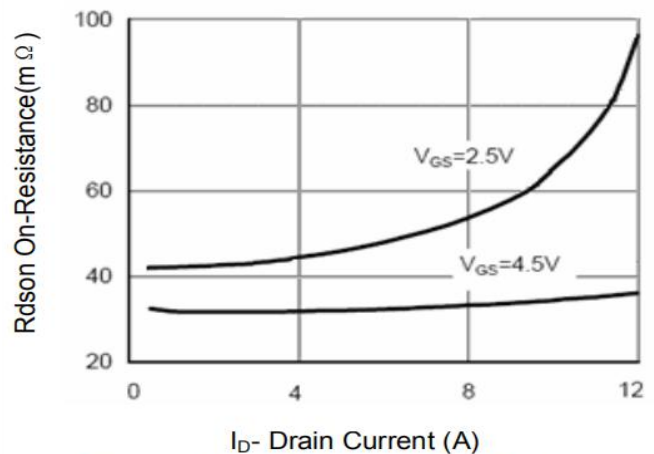

Figure 6 Drain-Source On-Resistance

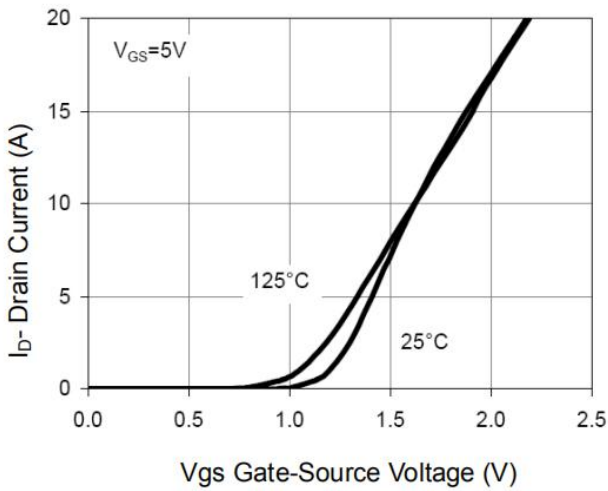

Figure 7 Transfer Characteristics

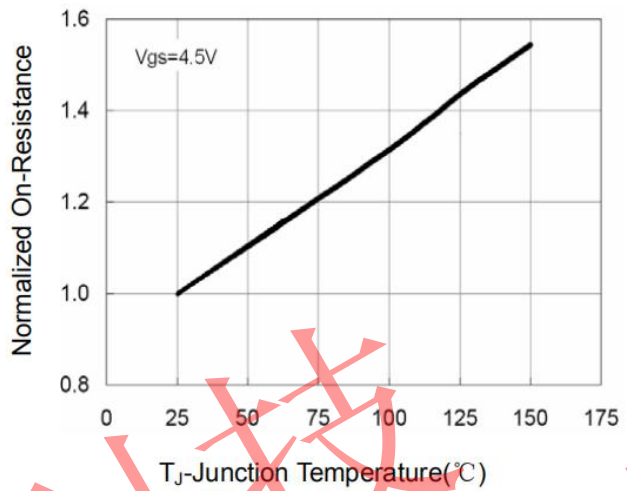

Figure 8 Drain-Source On-Resistance

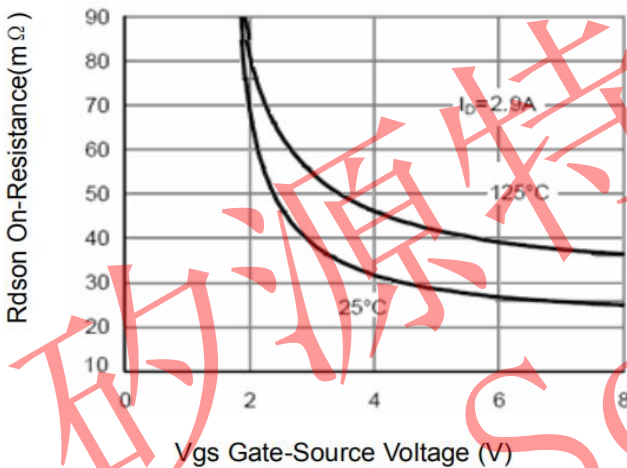

Figure 9 Rds(on) vs Vgs

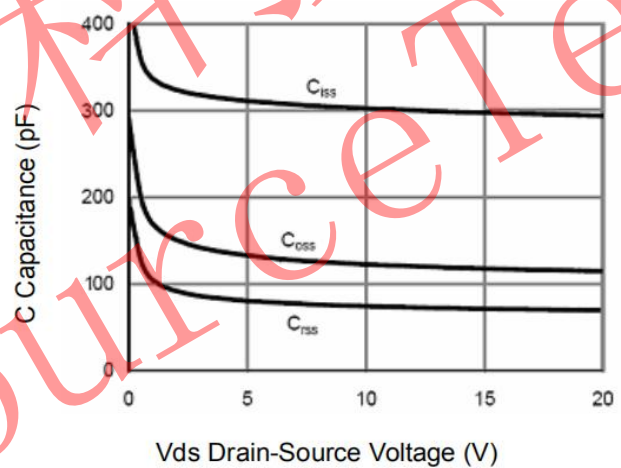

Figure 10 Capacitance vs Vds

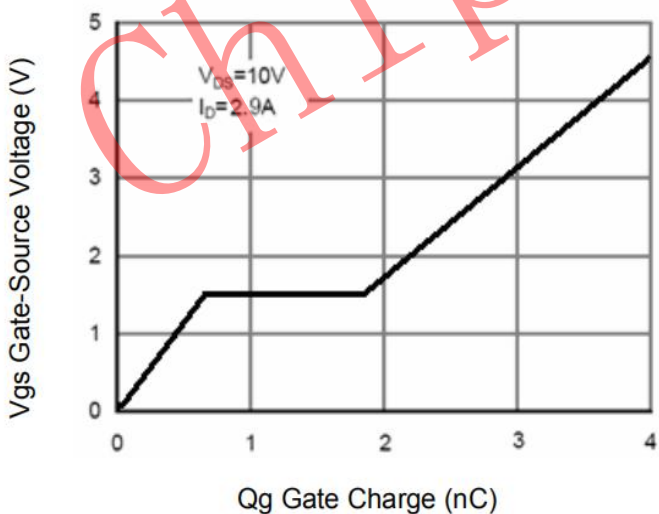

Figure 11 Gate Charge

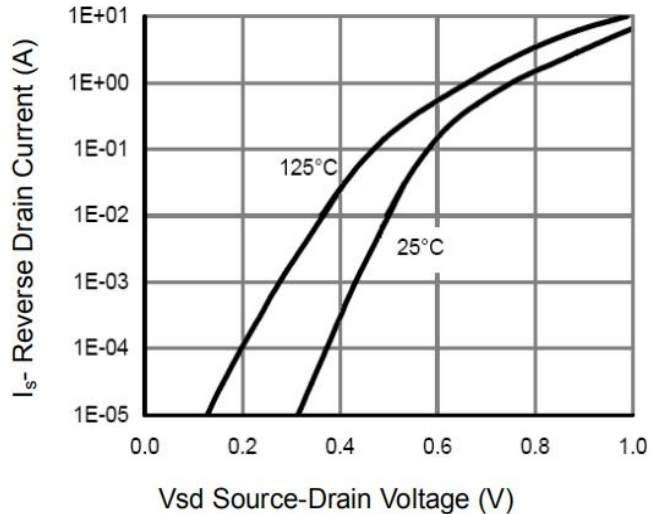

Figure 12 Source- Drain Diode Forward

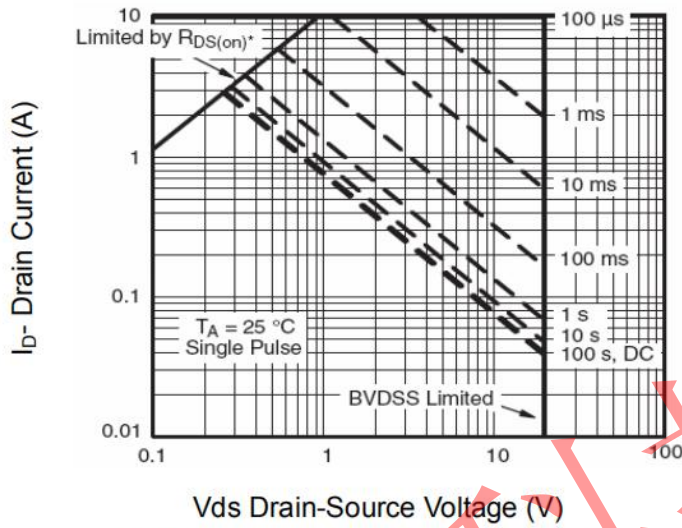

Figure 13 Safe Operation Area

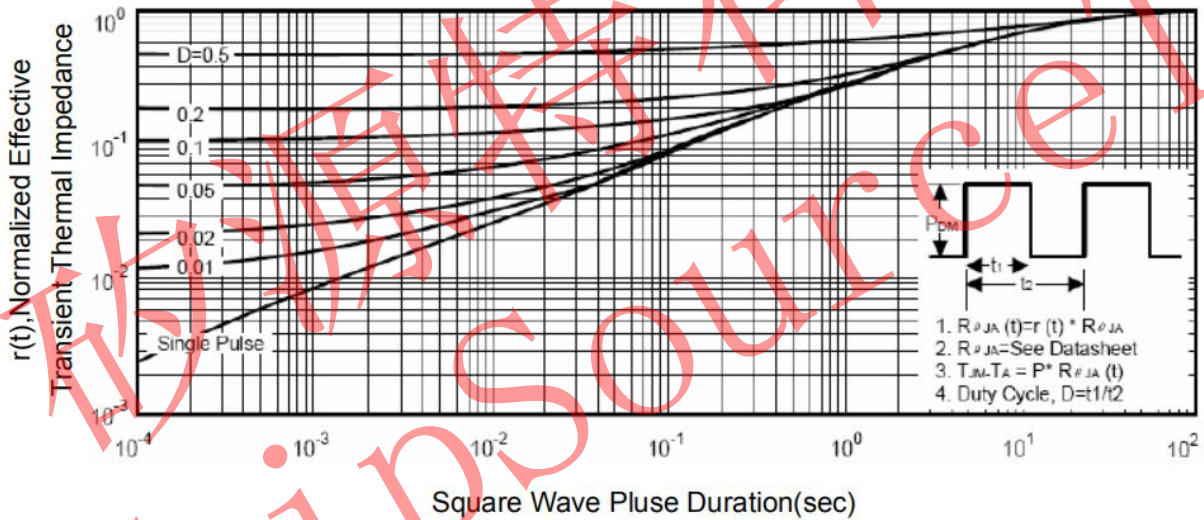

Figure 14 Normalized Maximum Transient Thermal Impedance



TYPICAL ELECTRICAL AND THERMAL CHARACTERISTICS

SOT-23 Package Information

Dimensions in Millimeters (UNIT:mm)

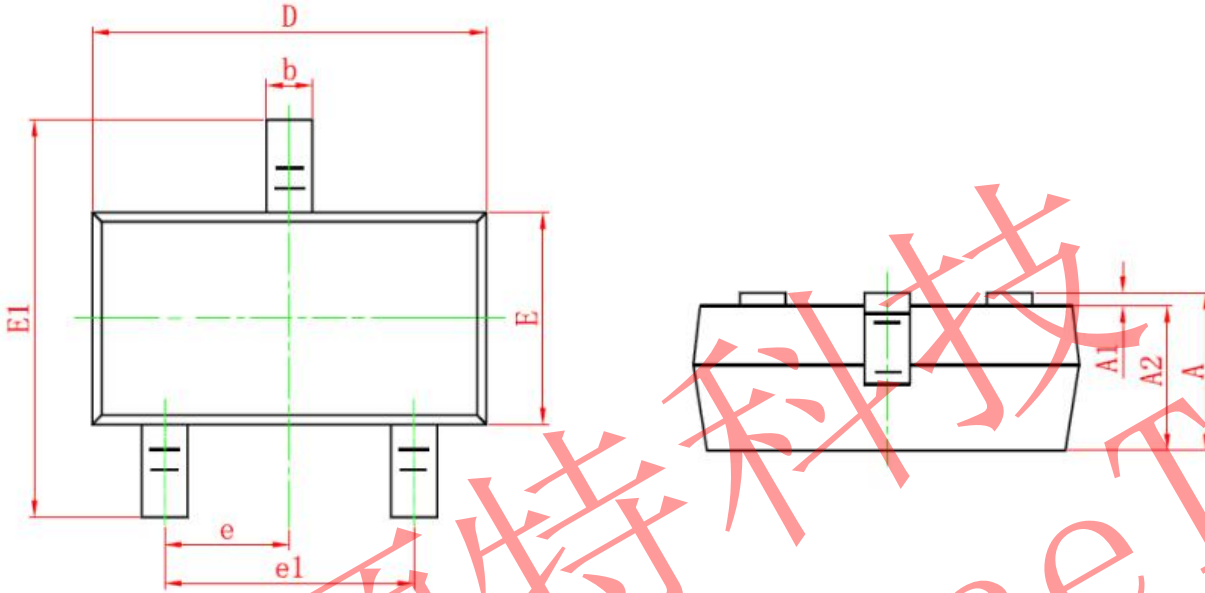

Symbol	Dimensions in Millimeters	
	MIN.	MAX.
A	0.900	1.150
A1	0.000	0.100
A2	0.900	1.050
b	0.300	0.500
c	0.080	0.150
D	2.800	3.000
E	1.200	1.400
E1	2.250	2.550
e	0.950TYP	
e1	1.800	2.000
L	0.550REF	
L1	0.300	0.500
θ	0°	8°