



## Description

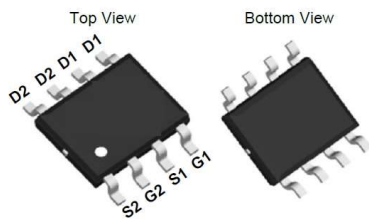
### Dual N-channel Enhancement Mode Power MOSFET

#### Features

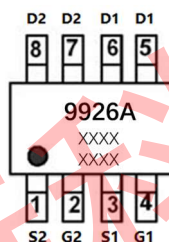
- 20V, 6.5A  
 $R_{DS(ON)} < 22m\Omega @ V_{GS} = 4.5V$   
 $R_{DS(ON)} < 27m\Omega @ V_{GS} = 2.5V$
- Advanced Trench Technology
- Provide Excellent  $R_{DS(ON)}$  and Low Gate Charge
- Lead free product is acquired

#### Application

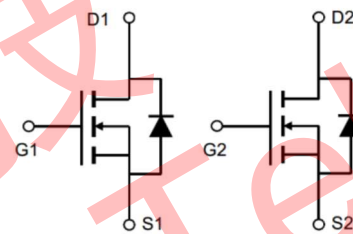
- Load Switch
- PWM Application
- Power management



SOP-8(Dual)



Marking and pin Assignment



Schematic Diagram

## Package Marking and Ordering Information

Device Marking	Device	OUTLINE	Device Package	Reel Size	Reel (PCS)	Per Carton (PCS)
9926A	JMTP9926A	TAPING	SOP-8	13inch	4000	48000

## Absolute Maximum Ratings (T<sub>A</sub>=25°C unless otherwise specified)

Symbol	Parameter	Max.	Units
V <sub>DSS</sub>	Drain-Source Voltage	20	V
V <sub>GSS</sub>	Gate-Source Voltage	±12	V
I <sub>D</sub>	Continuous Drain Current	T <sub>A</sub> = 25°C	6.5
		T <sub>A</sub> = 100°C	4
I <sub>DM</sub>	Pulsed Drain Current <sup>note1</sup>	26	A
P <sub>D</sub>	Power Dissipation	1.25	W
R <sub>θJA</sub>	Thermal Resistance, Junction to Ambient	100	°C/W
T <sub>J</sub> , T <sub>STG</sub>	Operating and Storage Temperature Range	-55 to +150	°C



**Electrical Characteristics** ( $T_J=25^{\circ}\text{C}$  unless otherwise specified)

Symbol	Parameter	Test Condition	Min.	Typ.	Max.	Units
<b>Off Characteristic</b>						
$V_{(BR)DSS}$	Drain-Source Breakdown Voltage	$V_{GS}=0V, I_D=250\mu A$	20	-	-	V
$I_{DSS}$	Zero Gate Voltage Drain Current	$V_{DS}=20V, V_{GS}=0V,$	-	-	1.0	$\mu A$
$I_{GSS}$	Gate to Body Leakage Current	$V_{DS}=0V, V_{GS}=\pm 12V$	-	-	$\pm 100$	nA
<b>On Characteristics</b>						
$V_{GS(th)}$	Gate Threshold Voltage	$V_{DS}=V_{GS}, I_D=250\mu A$	0.5	0.7	1.2	V
$R_{DS(on)}$	Static Drain-Source on-Resistance <small>note2</small>	$V_{GS}=4.5V, I_D=6.5A$	-	14	22	m $\Omega$
		$V_{GS}=2.5V, I_D=5A$	-	19	27	
<b>Dynamic Characteristics</b>						
$C_{iss}$	Input Capacitance	$V_{DS}=10V, V_{GS}=0V,$ $f=1.0MHz$	-	900	-	pF
$C_{oss}$	Output Capacitance		-	220	-	pF
$C_{rss}$	Reverse Transfer Capacitance		-	100	-	pF
$Q_g$	Total Gate Charge	$V_{DS}=10V, I_D=3A,$ $V_{GS}=4.5V$	-	12	-	nC
$Q_{gs}$	Gate-Source Charge		-	2.3	-	nC
$Q_{gd}$	Gate-Drain("Miller") Charge		-	1	-	nC
<b>Switching Characteristics</b>						
$t_{d(on)}$	Turn-on Delay Time	$V_{DS}=10V,$ $I_D=6A, R_{GEN}=3\Omega,$ $V_{GS}=4.5V$	-	10	-	ns
$t_r$	Turn-on Rise Time		-	11	-	ns
$t_{d(off)}$	Turn-off Delay Time		-	35	-	ns
$t_f$	Turn-off Fall Time		-	30	-	ns
<b>Drain-Source Diode Characteristics and Maximum Ratings</b>						
$I_S$	Maximum Continuous Drain to Source Diode Forward Current		-	-	6.5	A
$I_{SM}$	Maximum Pulsed Drain to Source Diode Forward Current		-	-	26	A
$V_{SD}$	Drain to Source Diode Forward Voltage	$V_{GS}=0V, I_S=6.5A$	-	-	1.2	V

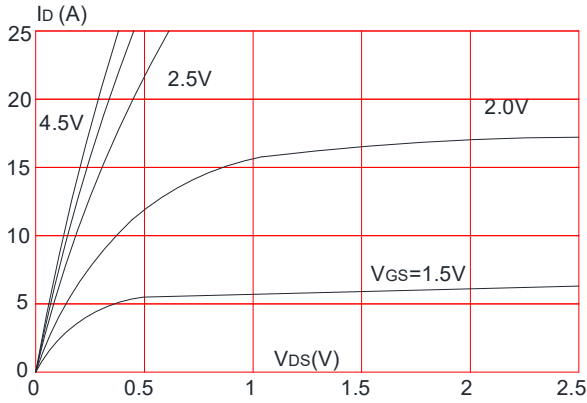
Notes: 1. Repetitive Rating: Pulse Width Limited by Maximum Junction Temperature

2. Pulse Test: Pulse Width $\leq 300\mu s$ , Duty Cycle $\leq 0.5\%$

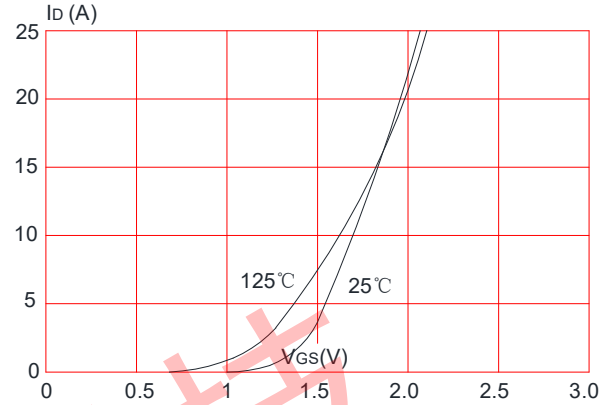


## Typical Performance Characteristics

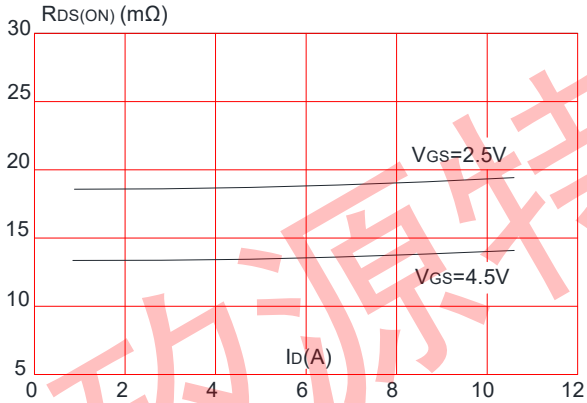
**Figure 1: Output Characteristics**



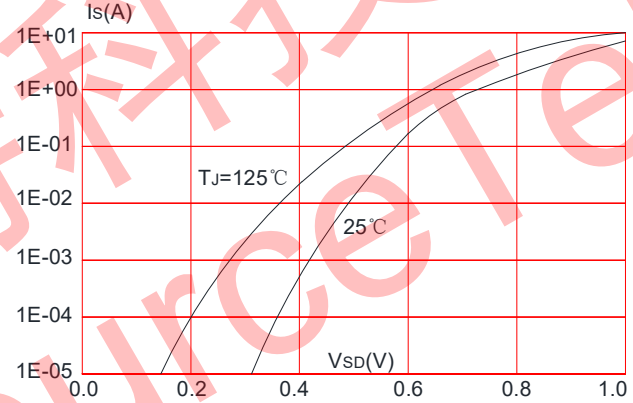
**Figure 2: Typical Transfer Characteristics**



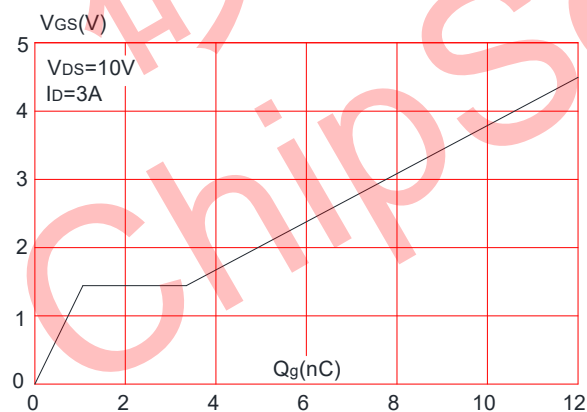
**Figure 3: On-resistance vs. Drain Current**



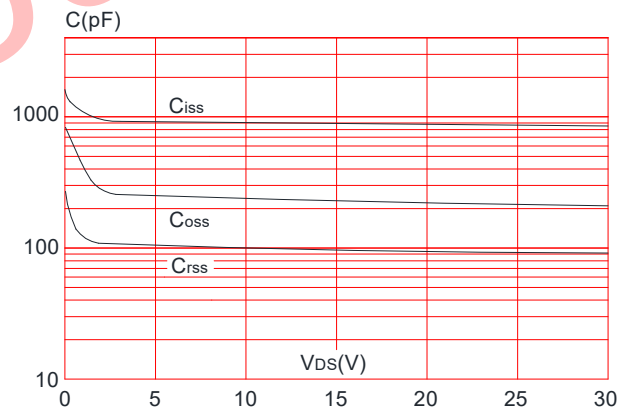
**Figure 4: Body Diode Characteristics**



**Figure 5: Gate Charge Characteristics**

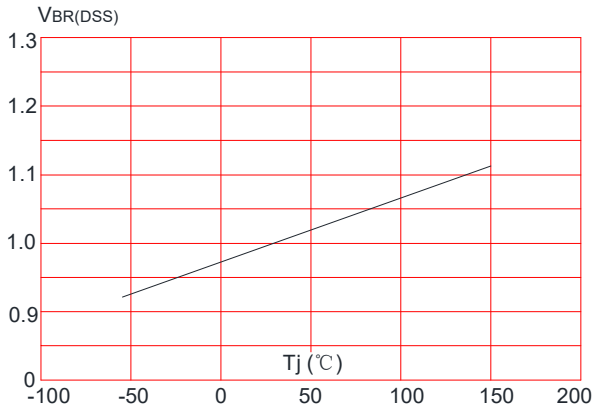


**Figure 6: Capacitance Characteristics**

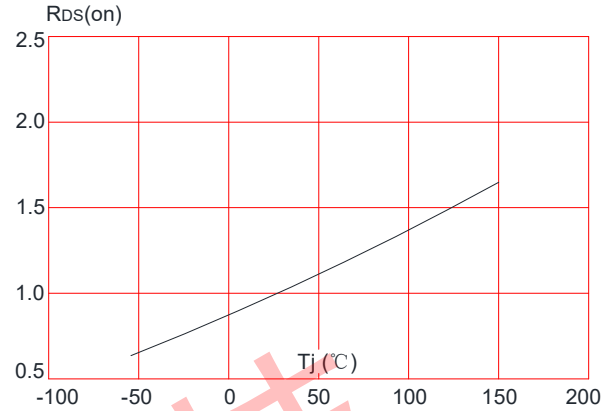




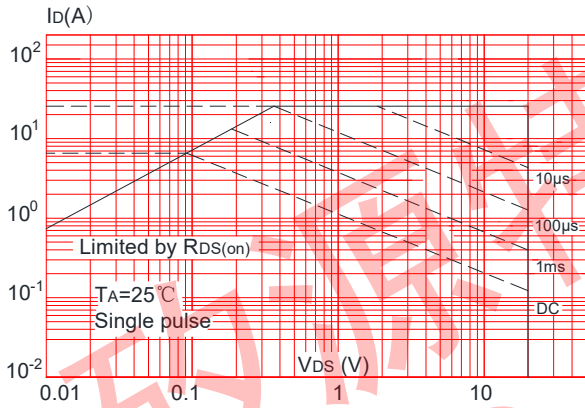
**Figure 7:** Normalized Breakdown Voltage vs. Junction Temperature



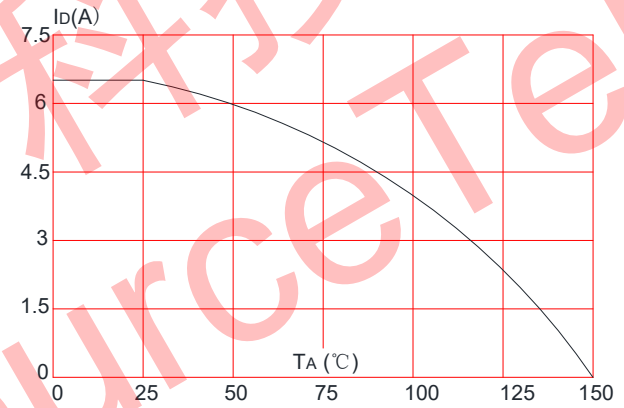
**Figure 8:** Normalized on Resistance vs. Junction Temperature



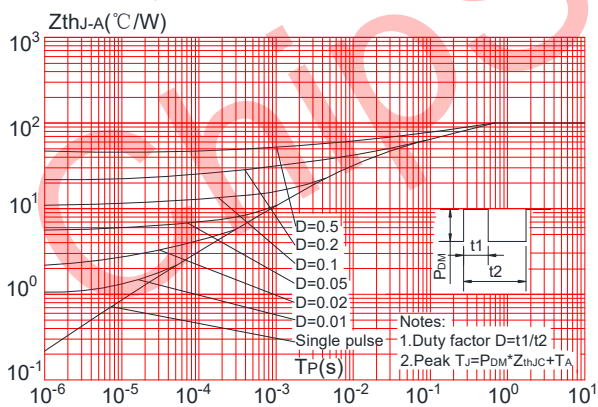
**Figure 9:** Maximum Safe Operating Area



**Figure 10:** Maximum Continuous Drain Current vs. Ambient Temperature



**Figure.11:** Maximum Effective Transient Thermal Impedance, Junction-to-Ambient





Test Circuit

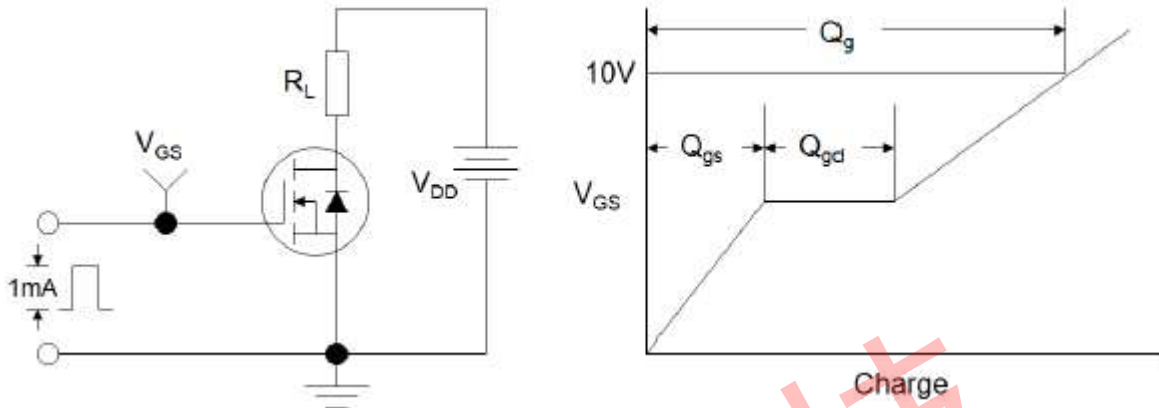


Figure1:Gate Charge Test Circuit & Waveform

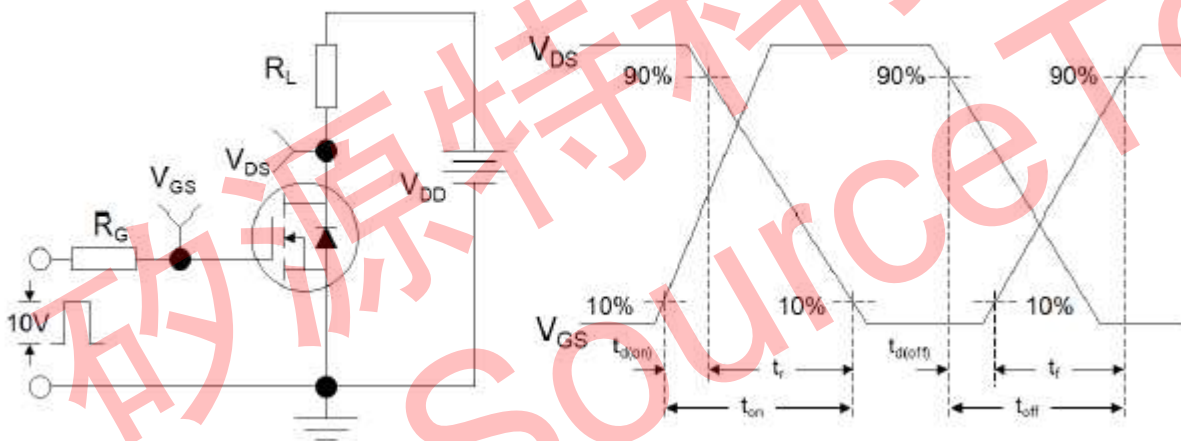


Figure 2: Resistive Switching Test Circuit & Waveforms

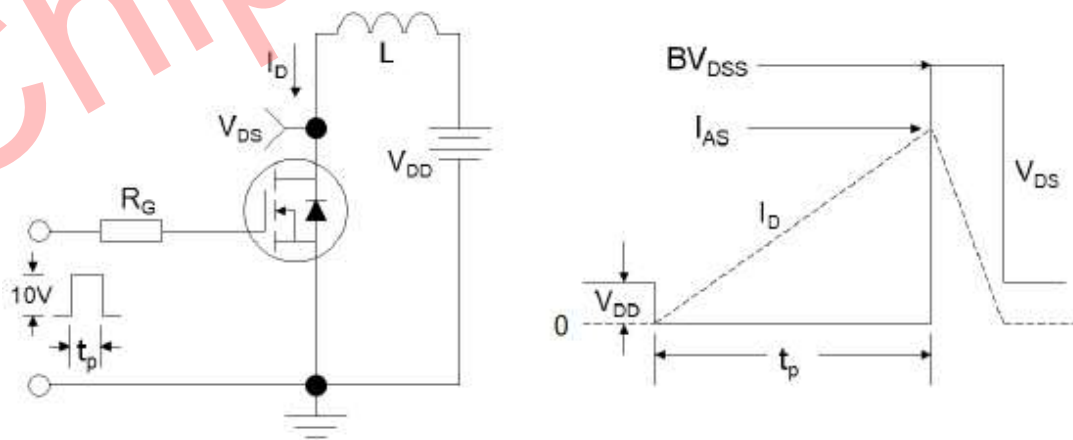


Figure 3:Unclamped Inductive Switching Test Circuit & Waveforms



Package Mechanical Data-SOP-8

