



FM8648

SP4T Switch for 2G/3G/4G TX Applications V1.0

Features

- Broadband frequency range: 0.4 to 2.7GHz
- Excellent insertion loss: 0.75dB @2.7GHz
- Input 0.1dB compression point: 32dBm
- High ESD robustness
- Small, LGA (9-pin, 1.1mm x 1.1mm x 0.5mm) package, MSL1
- RoHS compliant package

Applications

- 2G/3G/4G TX applications

Description

The FM8648 is a SOI SP4T switch suitable for GSM/LTE/UMTS/CDMA receiving applications. The FM8648 features very low insertion loss, high isolation and excellent linearity performance. The FM8648 has internal ESD protection devices to achieve excellent ESD performances. No DC Blocking capacitors are required for all RF ports unless DC is biased externally.

The FM8648 SP4T switch is provided in a LGA 9-pin 1.1mm x 1.1mm x 0.5mm package. The functional block diagram and the pin configuration are shown in Figure 1. Signal pin assignments and functional pin descriptions are provided in Table 1.

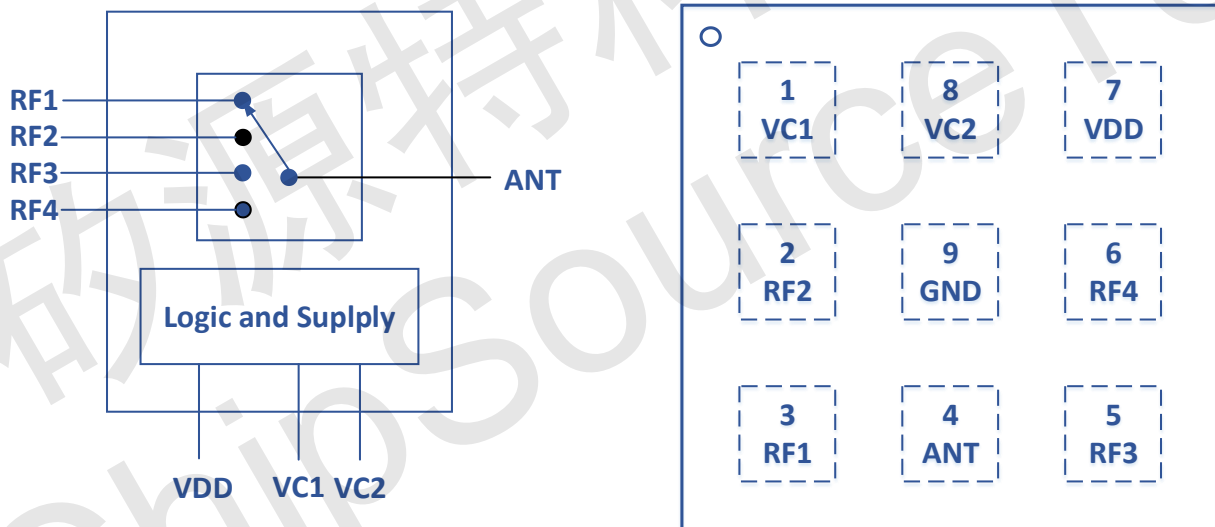

Figure 1. Functional Block and Pin Configuration



FM8648

SP4T Switch for 2G/3G/4G TX Applications V1.0

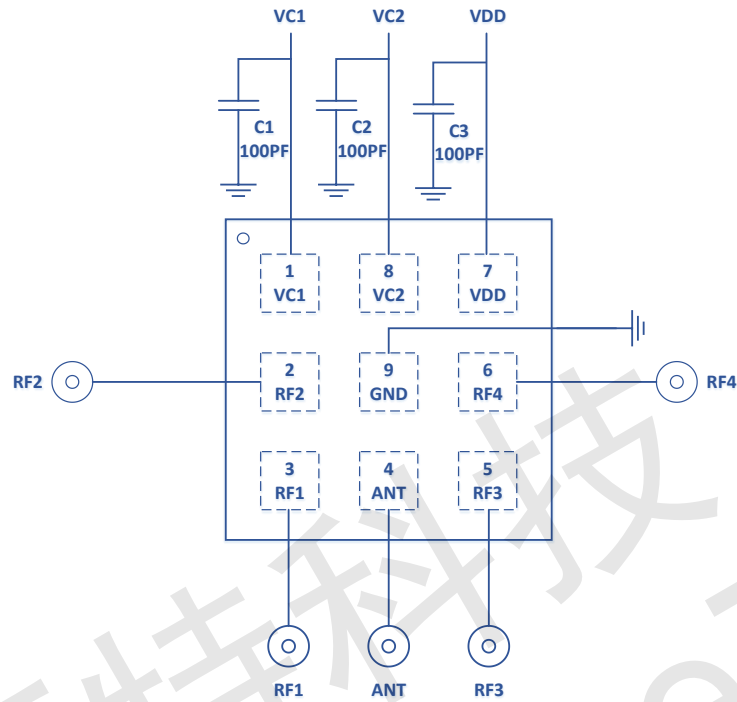

Figure 2. Application Circuit)

Table 1.FM8631 Signal Descriptions

NO.	Name	Description	NO.	Name	Description
1	VC1	Logic Control Voltage 1	6	RF4	RF Port 4
2	RF2	RF Port 2	7	VDD	DC Power Supply Voltage
3	RF1	RF Port 1	8	VC2	Logic Control Voltage 2
4	ANT	Antenna Port	9	GND	Ground
5	RF3	RF Port 3			

Table 2. FM8631 VC1/2/3 Truth Table for RF Channel Operating Mode

VC1	VC2	RF Channel Operating Mode
Low	High	ANT to RF1
High	Low	ANT to RF2
High	High	ANT to RF3
Low	Low	ANT to RF4

Electrical Characteristics



FM8648

SP4T Switch for 2G/3G/4G TX Applications V1.0

Table 3 Absolute Maximum Ratings

Parameter	Symbol	Min	Max	Unit	Condition
DC Supply Voltage	VDD	-0.3	4.5	V	TA=25°C
Control Logic Voltage(VC1/2/3)	VC	-0.3	3.5		TA=25°C
Peak RF Input Power (ANT to RF1/2/3/4)	PIN		32	dBm	F0=950MHz, 20%DC, VDD=1.8V, ZO=50Ω, TA=25°C
Device Operating Temperature	TOP	-40	90	°C	
Device Storage Temperature	TSTG	-55	150		
Electrostatic Discharge (All Pins)	VESD(HBM)	1000		V	Human Body Model
	VESD(CDM)	500			Charged Device Model

Notice

Exposure to maximum rating conditions for extended periods may reduce device reliability. There is no damage to device with only one parameter set at the limit and all other parameters set at or below their nominal value. Exceeding any of the limits listed here may result in permanent damage to the device.

Table 4 Recommended Operating Conditions

Parameter	Symbol	MIN	TYP	MAX	Unit
Operating Frequency	F0	0.4		2.7	GHz
DC Supply Voltage	VDD	2.5	2.8	5.0	V
Control Voltage High (VC1/2/3)	VCH	1.5	1.8	3.3	
Control Voltage Low(VC1/2/3)	VCL	0	0	0.3	



FM8648

SP4T Switch for 2G/3G/4G TX Applications V1.0

Table 5 Nominal Operating Parameters

Parameter	Symbol	Specification			Unit	Condition
		MIN	TYP	MAX		
Normal Condition	VDD=2.8V, VCH=1.8V, VCL=0V, PIN=0dBm, ZO=50Ω, TA=25°C, Unless Otherwise Stated					
DC Performances						
DC Supply Current	IDD		100	120	μA	
Current on VC	IC		0.5	5.0		
Timing Performances						
Switching Speed	TSW		2	5	μs	From 50% of VCTL to 10%/90% of final RF power
Startup Time	TON		5	10		From 50% of VDD to 90% of final RF power
RF Performances						
Insertion Loss (ANT to RF1/2/3/4)	IL		0.50	0.60	dB	F0=0.4 to 1.0GHz
			0.60	0.75		F0=1.1 to 2.0GHz
			0.75	0.80		F0=2.1 to 2.7GHz
Isolation (ANT to RF1/2/3/4)	ISO	32	35		dB	F0=0.4 to 1.0GHz
		28	30			F0=1.1 to 2.0GHz
		20	25			F0=2.1 to 2.7GHz
Input Return Loss (ANT to RF1/2/3/4)	RL		-15	-10		F0=0.4 to 3.8GHz
Input 0.1dB Compression Point (ANT to RF1/2/3/4)	P0.1dB		32		dBm	F0=950MHz, 20% DC



FM8648

SP4T Switch for 2G/3G/4G TX Applications V1.0

Package Outline Dimensions

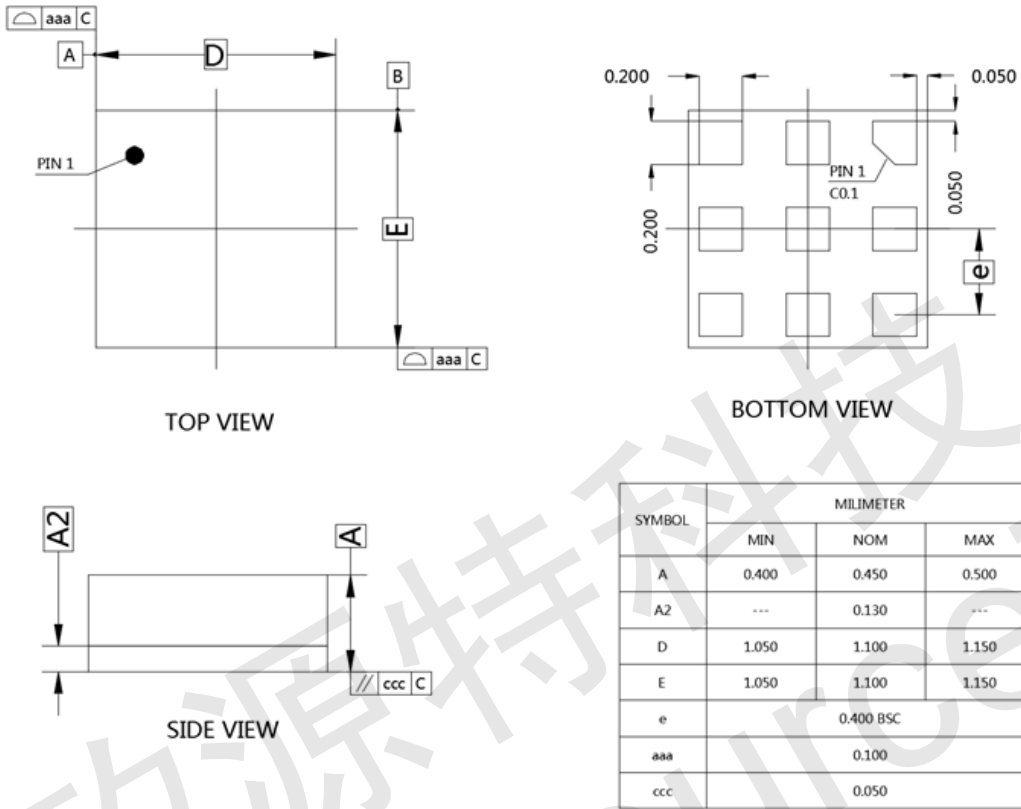

Figure 3. Package Outline Dimensions