



XYT3504 Micropower Synchronous Step-Up Converter

XYT3504 FEATURES

- High Efficiency: Up to 97%
- Low start-up voltage(load=1mA):0.8V
- The converter output voltage can be adjusted from 2.1V to 5.5V (in 0.1V step)
- Only Three External Components
- Low Quiescent Current: 10 μ A
- Over-Current Protection
- Thermal Fault Protection
- SOT23-3/SOT89-3/T092 package

XYT3504 GENERAL DESCRIPTION

The XYT3504 is PFM step-up DC-DC converter. The XYT3504 can start up by supply voltage as low as 0.8V, and capable of delivering maximum 200mA output current at 3.3V output with 1.8V input voltage. The XYT3504 is available in a Pb-free, space-saving low profile 3-pin SOT23, T092 or SOT89 package.

XYT3504 APPLICATIONS

- Power source for LED
- Power source for a single or dual-cell battery-powered equipments

XYT3504 TYPICAL APPLICATION

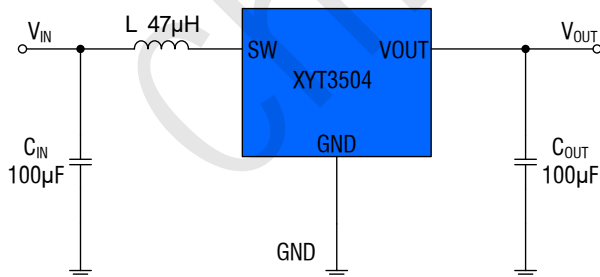

Figure 1. Basic Application Circuit



XYT3504 Micropower Synchronous Step-Up Converter

XYT3504 ABSOLUTE MAXIMUM RATINGS (Note 1)

Input Supply Voltage.....-0.3V to 6.5V	Lead Temperature(Soldering,10s).....300°C
SW Voltage.....-0.3V to (VIN+0.3V)	Storage Temperature Range.....-65°C to 150°C
Junction Temperature(Note2).....150°C	ESD HBM(Human Body Mode).....2kV
Operating Temperature Range.....-40°C to 85°C	ESD MM(Machine Mode).....200V

XYT3504 PACKAGE/ORDER INFORMATION

<p>TOP VIEW</p> <p>3-LEAD PLASTIC SOT-23</p>	<p>TOP VIEW</p> <p>3-LEAD PLASTIC SOT-89</p>	<p>3-LEAD PLASTIC T0-92</p>
Order Part Number		
XYT3504- <u>XX</u>	XYT3504- <u>XXS</u>	XYT3504- <u>XXT</u>
Package		
SOT23-3	SOT89-3	T092-3
Top Marking		
<u>B3XXDC</u>		

XX: Output voltage, D:Year, C:Week

XYT3504 PIN DESCRIPTION

Pin Name	Description
GND	Ground pin.
VOUT	Power Output Pin. Tied to the source of the PMOS synchronous rectifier
SW	Power Switch Pin. Ties to the drains of the PMOS synchronous rectifier and the NMOS switch



XYT3504 Micropower Synchronous Step-Up Converter

XYT3504 ELECTRICAL CHARACTERISTICS (Note 3)

($V_{OUT}=3.3V, T_A = 25^{\circ}C$, unless otherwise noted.)

PARAMETER	CONDITIONS	MIN	TYP	MAX	UNIT
Input Voltage Range	Minimum start-up voltage, $I_{LOAD}=1mA$			0.9	V
	Minimum Operating Voltage			0.6	V
Quiescent Current	$V=1.05*V_{OUT}$		12	18	μA
Output voltage accuracy		-3		3	%
Maximum on timer			2		μS
Minimum off timer			0.25		μS
On Resistance of PMOS	$I_{SW}=100mA$		300		$m\Omega$
On Resistance of NMOS	$I_{SW}=-100mA$		200		$m\Omega$
Peak Current Limit	$V_{IN}=3V, V_{OUT}=90\%$		1		A

Note 1: Absolute Maximum Ratings are those values beyond which the life of a device may be impaired.

Note 2: 100% production test at $25^{\circ}C$. Specifications over the temperature range are guaranteed by design and characterization.



XYT3504 Micropower Synchronous Step-Up Converter

XYT3504 TYPICAL PERFORMANCE CHARACTERISTICS

I_{LOAD} vs. Start Up Current

$C_{IN}=C_{OUT}=100\mu F$, $L=47\mu H$, $V_{OUT}=2.7V$

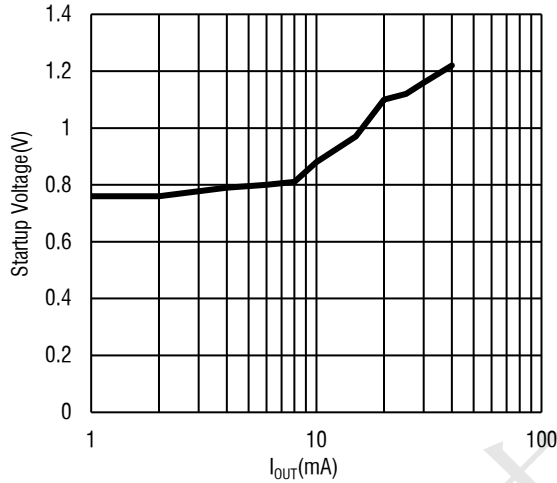

I_{OUT} vs. Efficiency

$C_{IN}=C_{OUT}=100\mu F$, $L=47\mu H$, $V_{OUT}=2.7V$

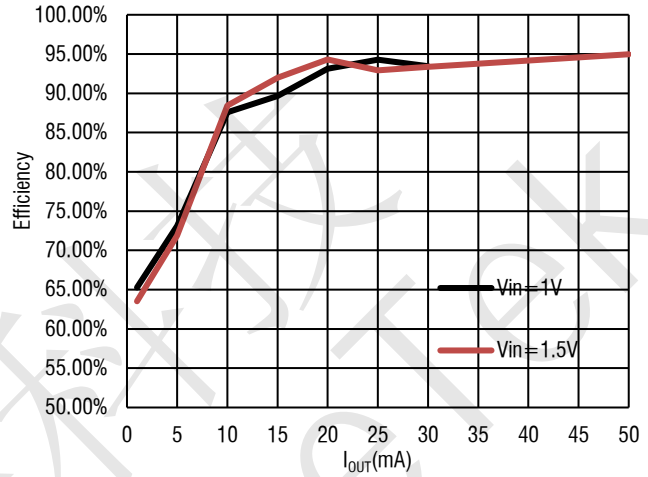

V_{OUT} vs. I_{OUT}

$C_{IN}=C_{OUT}=47\mu F$, $L=10\mu H$, $V_{OUT}=3V$

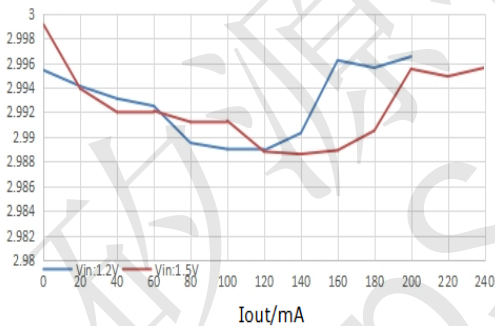

I_{OUT} vs. Efficiency

$C_{IN}=C_{OUT}=47\mu F$, $L=10\mu H$, $V_{IN}=1V$, $V_{OUT}=3V$

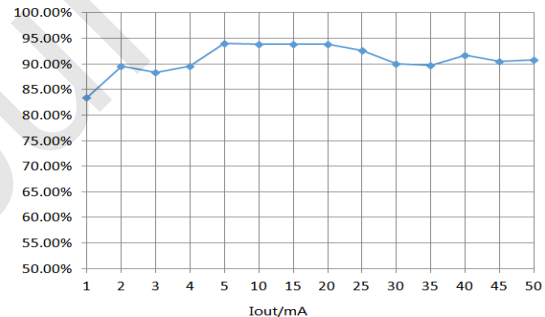

I_{OUT} vs. Efficiency

$C_{IN}=C_{OUT}=47\mu F$, $L=10\mu H$, $V_{IN}=1.5V$, $V_{OUT}=3V$

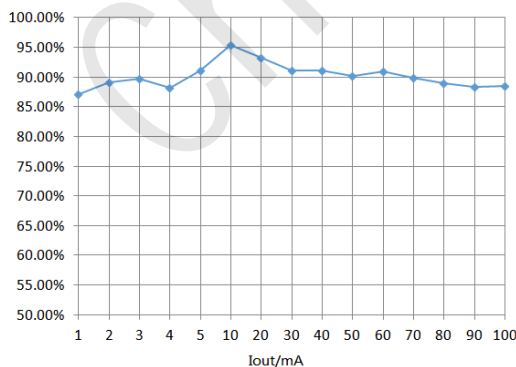

Ripple ($V_{IN}=2V$, $V_{OUT}=2.7V$, $I_{LOAD}=20mA$,

$C_{IN}=C_{OUT}=100\mu F$, $L=47\mu H$)

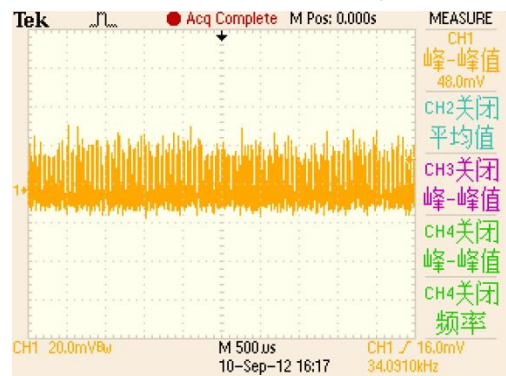



XYT3504 Micropower Synchronous Step-Up Converter

Ripple($V_{IN}=1V$, $V_{OUT}=2.7V$, $I_{LOAD}=20mA$,
 $C_{IN}=C_{OUT}=100\mu F$, $L=47\mu H$)

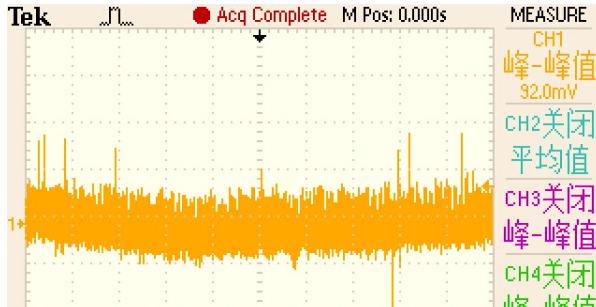

Ripple($V_{IN}=1.5V$, $V_{OUT}=2.7V$, $I_{LOAD}=20mA$,
 $C_{IN}=C_{OUT}=100\mu F$, $L=47\mu H$)

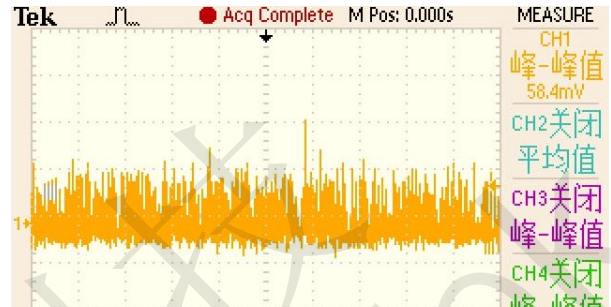

XYT3504 FUNCTIONAL BLOCK DIAGRAM

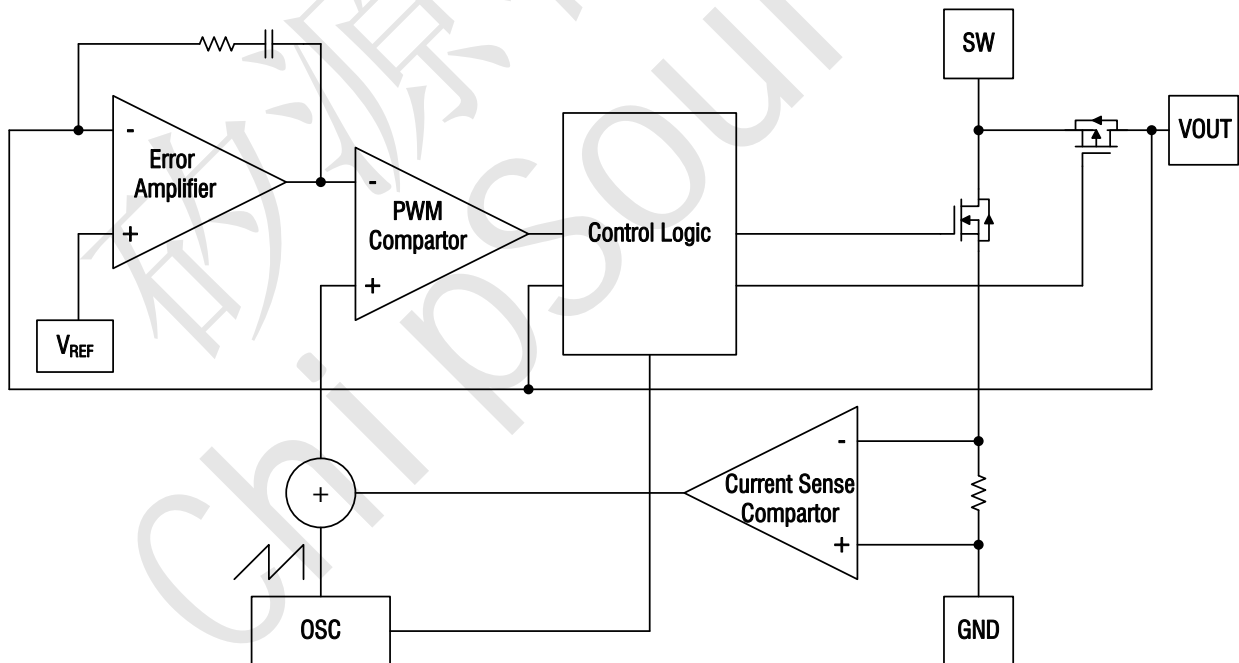

Figure 2. XYT3504 Block Diagram



XYT3504 Micropower Synchronous Step-Up Converter

XYT3504 FUNCTIONAL DESCRIPTION

The XYT3504 is a high performance PFM Mode operation only, synchronous boost converter requiring only three small external components. Its simplicity and small size make it a high efficiency alternative to charge pump designs. It is designed to start up from a single alkaline or nickel cell, with input voltages as low as 0.9V, or from two or three cells (or a Li-Ion battery), with voltages as high as 4.5V. Once started, V_{IN} can be as low as 0.6V (depending on load current) and maintain regulation. The output voltage is preset internally from 2.1V to 5.5V (in 0.1V step). Synchronous rectification provides high efficiency operation while eliminating the need for an external Schottky diode. True output disconnect eliminates inrush current at start-up,

and allows V_{OUT} to be disconnected from V_{IN} , for zero shutdown current.

The operating quiescent current is only $10\mu A$ typical, allowing the converter to maintain high efficiency at extremely light loads.

XYT3504 APPLICATIONS INFORMATION

Component Selection

Inductor values between $4.7\mu H$ and $47\mu H$ are recommended. In most applications $10\mu H$ will yield the best compromise between size and efficiency. The inductor should be a low loss ferrite design and must be rated for peak currents of at least 1000mA without saturating. Inductors with lower DC resistance will improve efficiency. Note that the inductor value does not have a significant effect on ripple current, so while lower values will increase the operating frequency, they do not reduce output voltage ripple. If the battery is more than a few inches

away, a bulk tantalum cap of at least $10\mu F$ is recommended on V_{IN} . The output capacitor should also be located close to the V_{OUT} and GND pins. A minimum value of $10\mu F$ is recommended. Increasing the value of the output capacitor to $22\mu F$ will result in lower output ripple. Higher capacitor values will only offer a small reduction in output ripple, while reducing light load efficiency by causing the peak inductor current to increase above its minimum value. The input and output capacitors should be X5R or X7R types, not Y5V.



XYT3504 Micropower Synchronous Step-Up Converter

XYT3504 PACKAGE DESCRIPTION

SOT23-3

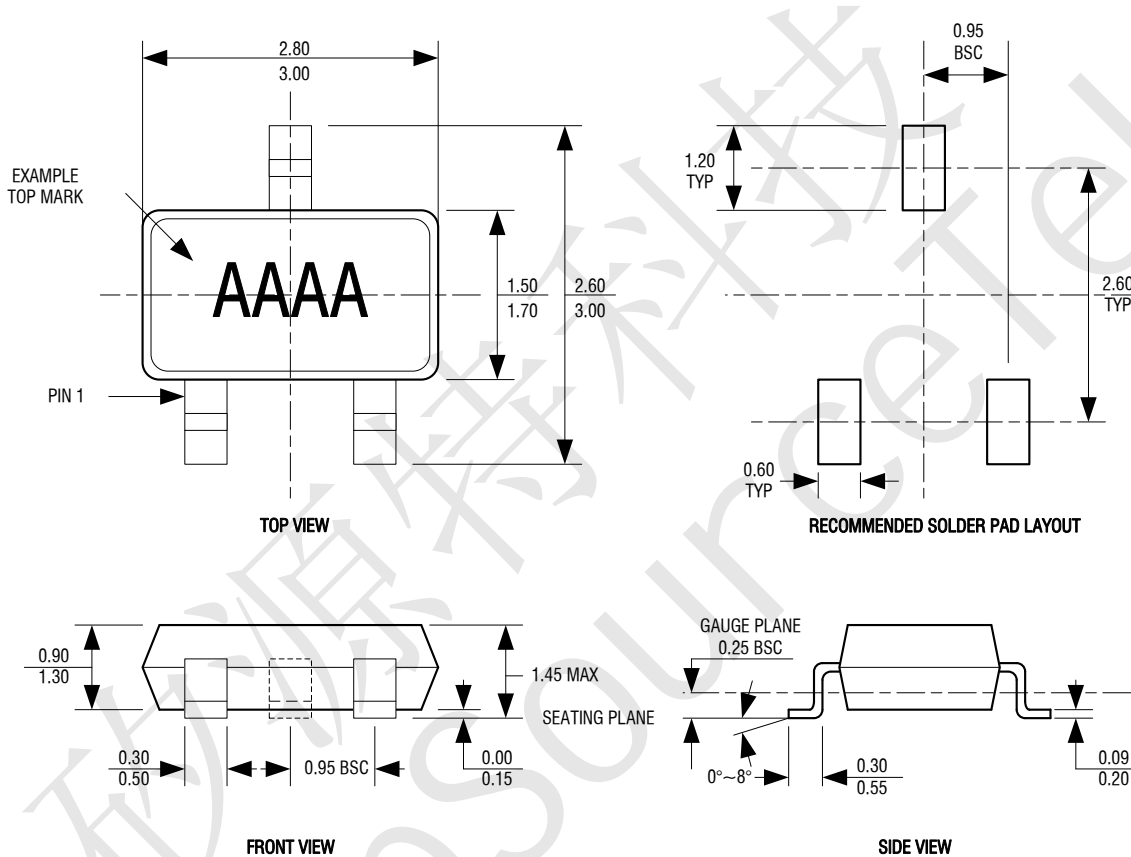

NOTE:

- 1.DIMENSIONS ARE IN MILLIMETERS.
- 2.DRAWING NOT TO SCALE.
- 3.DIMENSIONS ARE INCLUSIVE OF PLATING.
- 4.DIMENSIONS ARE EXCLUSIVE OF MOLD FLASH AND METAL BURR.



XYT3504 Micropower Synchronous Step-Up Converter

SOT89-3

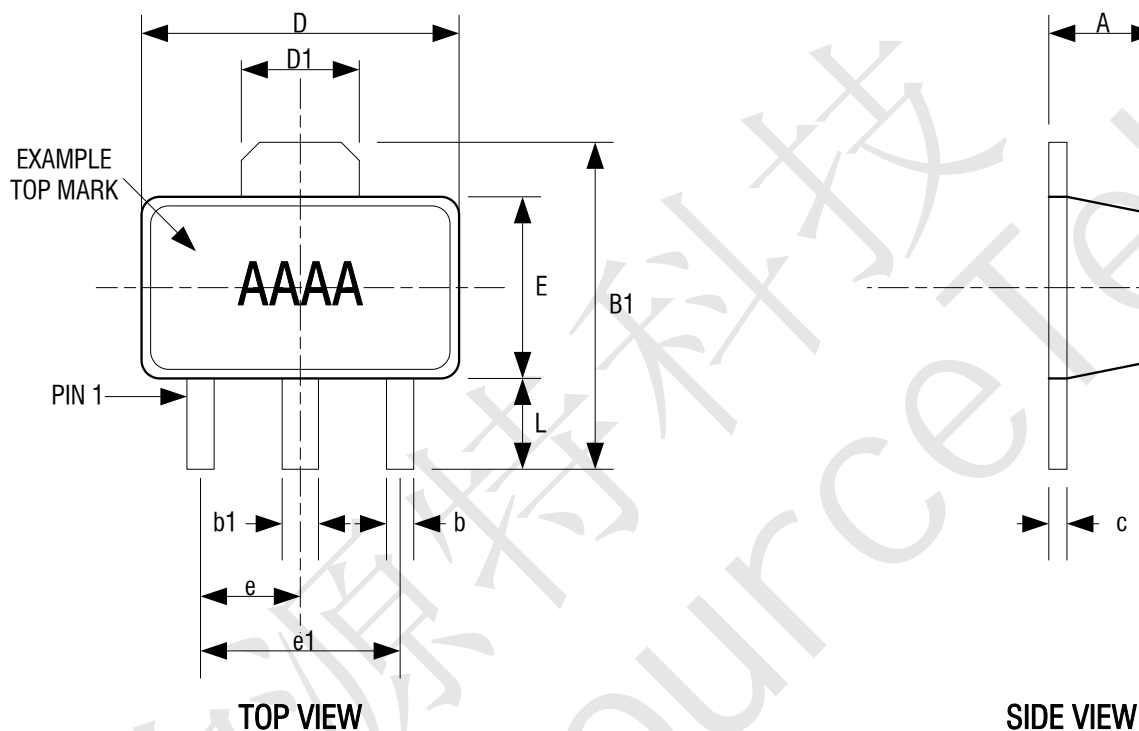

Symbol	Dimensions In Millimeter		Dimensions In Inches	
	Min	Max	Min	Max
A	1.400	1.600	0.055	0.063
b	0.320	0.520	0.013	0.197
b1	0.400	0.580	0.016	0.023
c	0.350	0.440	0.014	0.017
D	4.400	4.600	0.173	0.181
D1	1.550 REF		0.061 REF	
E	2.300	2.600	0.091	0.102
E1	3.940	4.250	0.155	0.167
e	1.500 TYP		0.060 TYP	
e1	3.000 TYP		0.118 TYP	
L	0.900	1.200	0.035	0.047



XYT3504 Micropower Synchronous Step-Up Converter

T092-3

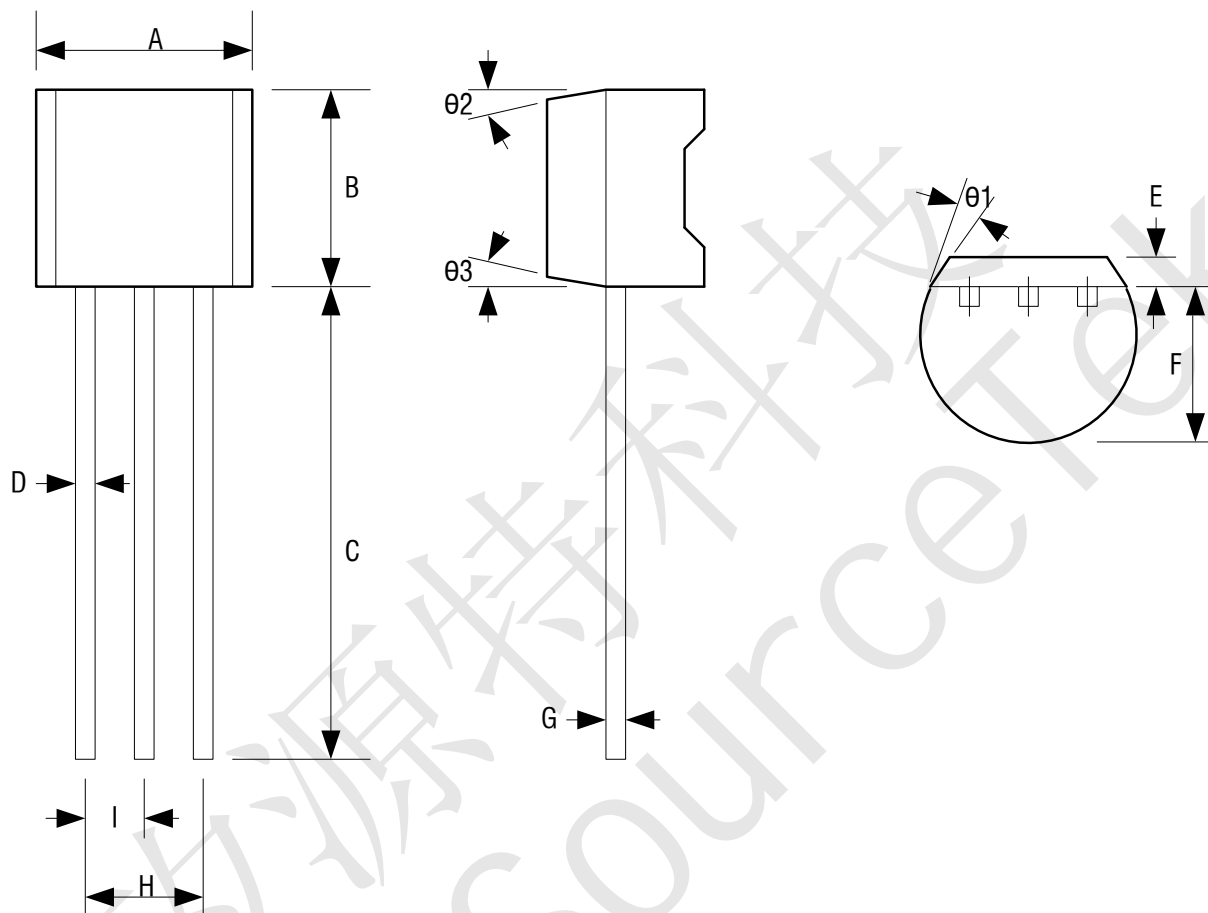

Symbol	Dimensions In Millimeter			Dimensions In Inches		
	Min	Nom	Max	Min	Nom	Max
A	4.33	4.58	4.83	0.170	0.180	0.190
B	4.33	4.58	4.83	0.170	0.180	0.190
C	14.07	14.47	14.87	0.554	0.570	0.585
D	0.34	0.44	0.54	0.013	0.017	0.021
E	0.92	1.02	1.12	0.036	0.040	0.044
F	3.36	3.56	3.76	0.132	0.140	0.148
G	0.34	0.44	0.54	0.013	0.017	0.021
H	2.42	2.54	2.66	0.095	0.100	0.105
I	1.15	1.27	1.39	0.045	0.050	0.055
$\theta 1$	-	5°	-	-	5°	-
$\theta 2$	-	2°	-	-	2°	-
$\theta 3$	-	2°	-	-	2°	-



XYT3504 Micropower Synchronous Step-Up Converter

IMPORTANT NOTICE

Shenzhen ChipSourceTek Technology Co.,Ltd reserve the right to make corrections, enhancements, improvements and other changes to its semiconductor products and services.

Shenzhen ChipSourceTek Technology Co.,Ltd is not responsible or liable for such altered documentation. Information of third parties may be subject to additional restrictions.

Shenzhen ChipSourceTek Technology Co.,Ltd does not assume any responsibility for use of any its products for any particular purpose, nor does Shenzhen ChipSourceTek Technology Co.,Ltd assume any liability arising out of the application or use of any its products or circuits.