



TC618CS Single Channel DC Motor Driver

TC618CS Summary

This product provides an integrated brush DC motor drive solution for battery powered toys, low-voltage or battery powered motion control applications. The H-bridge drive circuit designed with n-channel and p-channel power MOSFET is integrated in the circuit, which is suitable for driving a winding of a brush DC motor or a stepping motor. The circuit has a wide working voltage range (from 2V to 9.6V), the maximum continuous output current reaches 2.1A, and the maximum peak output current reaches 3.5A.

TC618CS Characteristic

- Single channel built-in power MOS full bridge drive.
- Drive forward, backward, stop and brake function.
- Built in hysteresis thermal effect OTP.
- Low on resistance(0.26 Ω)
- The Max continuous output current can reach 2.1A, and the peak current is 3.5A
- No need for peripheral filter capacitor
- ESOP-8 Packing.

TC618CS Application

- Toy motor drive

TC618CS Packing

- ESOP-8

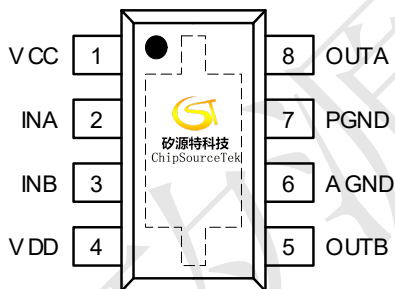

PIN NO	Pin Name	I/O	Function
1	VCC	--	Logic control power terminal
2	INA	I	Forward logic input
3	INB	I	Reverse logic input
4	VDD	--	Power supply terminal
5	OUTB	O	Reverse output
6	AGND	--	Logic control circuit ground terminal
7	PGND	--	Output power tube ground terminal
8	OUTA	O	Forward rotation output

TC618CS Typical Application Circuit

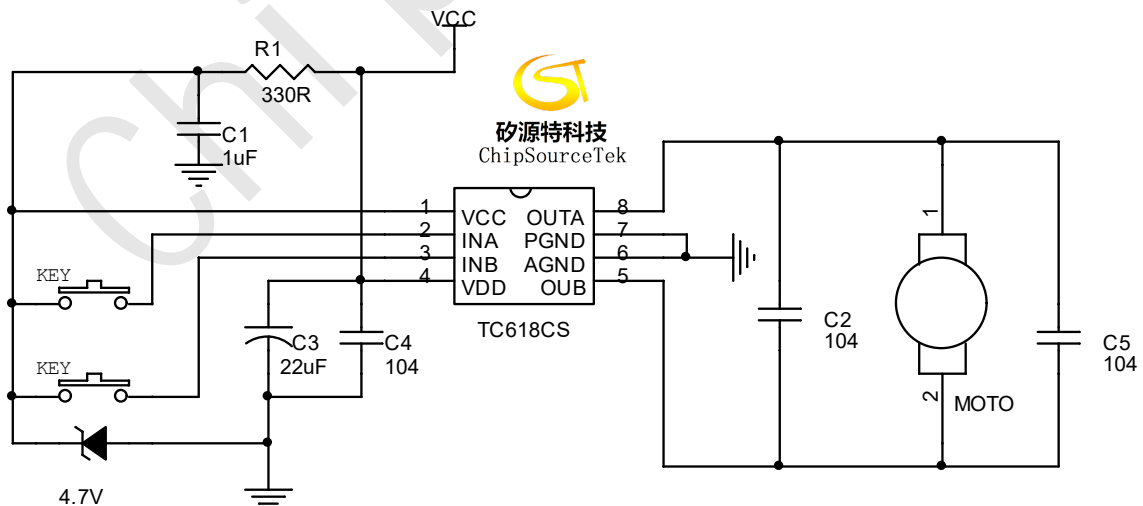



TC618CS Block Diagram

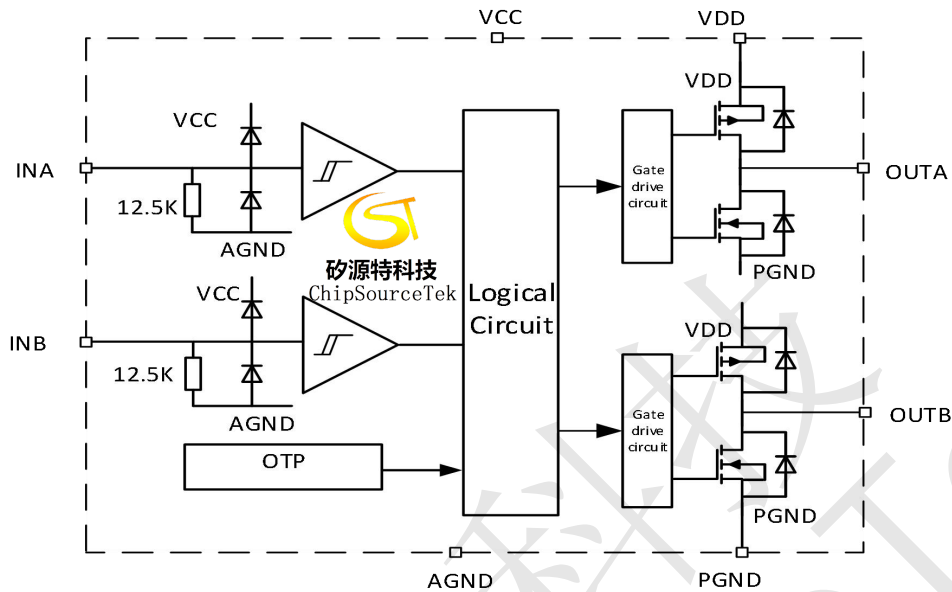

TC618CS Absolute Maximum Rating

Rating	Symbol	Value	Unit	
Logic supply voltage	VCC	7	V	
Power supply voltage	VDD	11	V	
Power	Pd	ESOP-8	0.96	W
Thermal resistance	θ_{JA}	ESOP-8	130	$^{\circ}\text{C}/\text{W}$
Operating temperature	Topr	-20~85	$^{\circ}\text{C}$	
Junction temperature	Tj	150	$^{\circ}\text{C}$	
Storage temperature	Tstg	-55~150	$^{\circ}\text{C}$	
Welding temperature		350~370	$^{\circ}\text{C}$	
Peak current of output	Iop	3.5	A	
Maximum continuous output current	Ioc	2.1	A	

TC618CS Recommended working conditions

Rating	Symbol	Value	Unit
Power supply voltage	VDD	2.0~9.6	V
Logic supply voltage	VCC	2~5V	V
Control input voltage	VIN	0~5	V
Forward and reverse output current	Iout	-2100~2100	mA



TC618CS Electrical Characteristics

Characteristics	Symbol	Conditions	MIN	TYPE	MAX	Unit
Circuit turn-off current	ICCST	INA=INB=1	—	0	10	uA
	IDDST		—	0	10	uA
Operating current	ICC	INA=H, INB=L or	—	85	—	uA
	IDD	INA=L, INB=H	—	140	—	uA
High level input voltage	VINH		2.0	—	—	V
Low level input voltage	VINL		—	—	0.8	V
High level input current	IINH	VIN=3V	—	250	400	uA
Low level input current	IINL	VIN=0V	-1	0	—	uA
Pull down resistance	RIN		—	12	—	KΩ
Output conduction impedance	RON	Io=±200mA	—	0.26	0.6	Ω

TC618CS Input / output logic table

INPUT		OUTPUT		Mode
INA1/2	INB1/2	OUTA1/2	OUTB1/2	
L	L	Hi-Z	Hi-Z	Standby status
H	L	H	L	Forward
L	H	L	H	Backward
H	H	L	L	Brake

TC618CS Input / output waveform

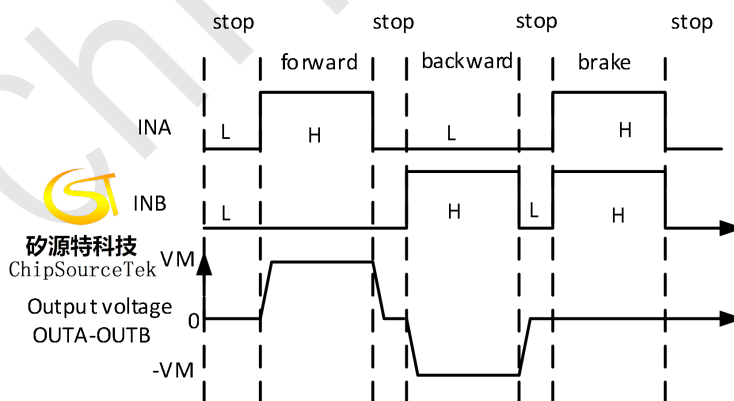



TC618CS Application reference circuit and PCB wiring guidance

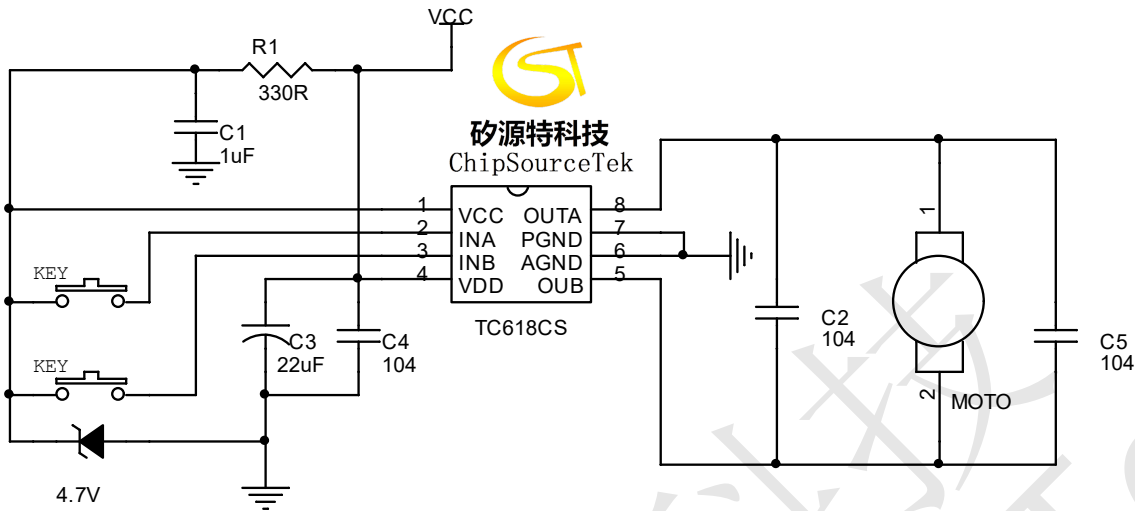

Note: In the figure, the C2 capacitor is placed on the PCB board, which can be used or omitted depending on the interference degree of the motor used. Of course, the plug-in 104 connected to the motor cannot be omitted. In different applications, only one C3 and C4 can be installed: in 3V applications, it is recommended to use at least one 1uF VDD capacitor; At least one 4.7uF is used in 4.5V applications; At least one 10uF is used in 6V applications; Use at least one 22uF in 9V applications. All of them are placed close to the VDD pin of the IC using the chip capacitor, and the connection between the negative pole of the capacitor and the GND end of the IC should also be as short as possible. That is, although the capacitance is close, the wiring and routing are far away. VDD connection shall be as short as possible. Otherwise, VDD shall have its own capacitance. In addition, when using a large electrolytic plug-in capacitor, it is recommended to add another 100nF chip capacitor to the VDD pin.

Precautions for chip use

1. The above recommended circuits and parameters are only applicable to ordinary remote control car toys. When using TC618CS for other toys and motor drives, please use them according to the actual situation.
2. The continuous current drive capability is affected by the packaging form, VDD, VCC, chip difference, ambient temperature, PCB material and thickness and other factors. The parameters given in the specification are for reference only. In actual use, please consider a certain margin according to the product.
3. TC618CS is designed and manufactured by MOS process and is sensitive to static electricity. It is required to pay attention to anti-static measures in the whole process of packaging, transportation, processing and production.
4. The locked rotor current value of the motor should not exceed the peak current of the chip by 3.5A. Exceeding this value is likely to cause the chip to burn.
5. The reverse connection of power supply will cause permanent damage to the chip, and in serious cases, it will cause the plastic packaging material to smoke. It can be considered to add Schottky diodes to VDD to prevent reverse connection.



TC618CS Package dimension drawing

➤ ESOP-8

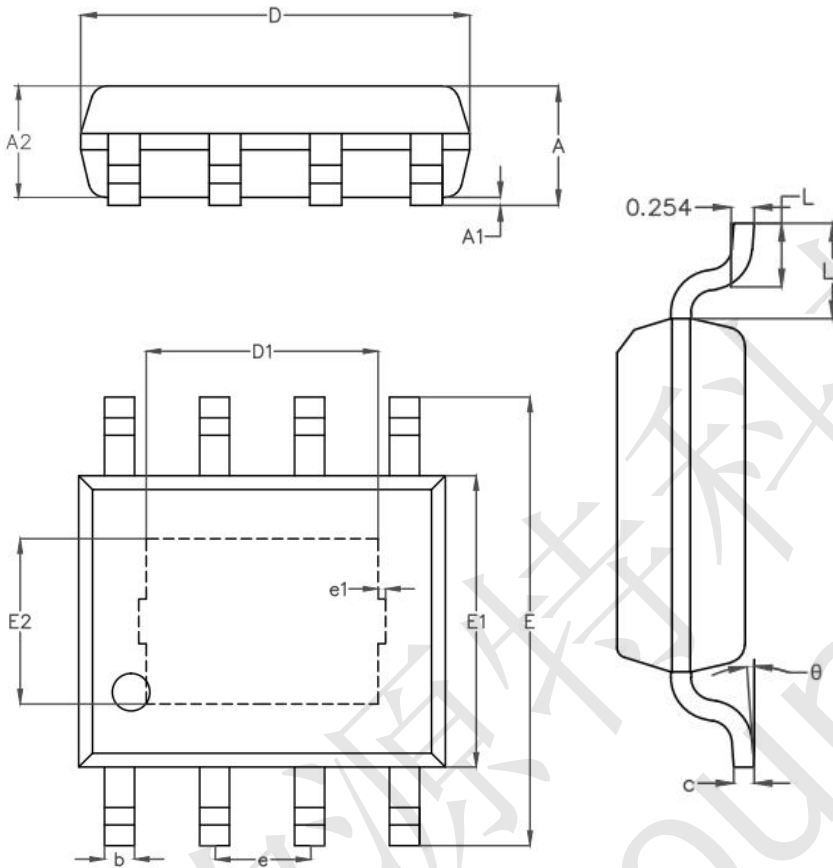

SYMBOL	MILLIMETER		
	MIN	NOM	MAX
A	1.38	1.50	1.60
A1	0.03	0.10	0.15
A2	1.35	1.40	1.45
A3	0.55	0.60	0.65
b	0.35	0.40	0.45
c	0.19	0.22	0.25
D	4.85	4.90	4.95
D1	3.07	3.17	3.27
E	5.80	6.00	6.20
E1	3.85	3.90	3.95
E2	2.18	2.28	2.38
e	1.22	1.27	1.32
e1	0.05	0.10	0.15
L	0.45	0.60	0.75
L1	1.00	1.05	1.10
θ	0°	4°	8°