



MOT50N06C/MOT50N06D N-CHANNEL MOSFET

■ MOT50N06C/D PRODUCT CHARACTERISTICS

VDSS	60V
R _{DS(on)} Typ(@V _{GS} =10 V)	13mΩ
ID	50A

■ MOT50N06C/D Pin Configuration

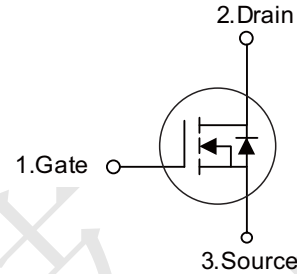

■ MOT50N06C/D APPLICATIONS

- * Switching applications

■ MOT50N06C/D FEATURES

- * High Switching Speed
- * Improved dv/dt capability

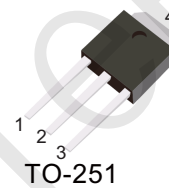

■ MOT50N06C/D ORDER INFORMATION

Order codes		Package	Packing
Halogen-Free	Halogen		
N/A	MOT50N06D	TO-252	2500 pieces /Reel
N/A	MOT50N06C	TO-251	70 pieces/Tube

■ MOT50N06C/D ABSOLUTE MAXIMUM RATINGS

PARAMETER	SYMBOL	RATINGS	UNIT
Drain-Source Voltage	V _{DSS}	60	V
Gate-Source Voltage	V _{GSS}	±20	V
Continuous Drain Current	I _D	50	A
Pulsed Drain Current (Note 2)	I _{DM}	150	A
Avalanche Energy	Single Pulsed (Note 3)	E _{AS}	92
Peak Diode Recovery dv/dt			
Power Dissipation	TO-251/TO-252	P _D	46
Junction Temperature	T _J	+150	°C
Operation and Storage Temperature	T _{STG}	-55 ~ +150	°C

Notes: 1. Absolute maximum ratings are those values beyond which the device could be permanently damaged.

Absolute maximum ratings are stress ratings only and functional device operation is not implied.

2. Repetitive Rating : Pulse width limited by maximum junction temperature.

3. L=43mH, I_{AS}=43A, V_{DD}=25V, R_G=20Ω, Starting T_J=25°C

4. I_{SD} ≤ 30A, V_{DS}=0V, di/dt ≤ 200A/μs, V_{DD} ≤ BV_{DSS}, Starting T_J = 25°C

■ MOT50N06C/D THERMAL DATA

PARAMETER	SYMBOL	RATING	UNIT
Junction to Ambient	TO-251/TO-252	θ _{JA}	100
Junction to Case	TO-251/TO-252	θ _{JC}	2.7 (Note)



■ MOT50N06C/D ELECTRICAL CHARACTERISTICS (T_c=25°C, unless otherwise specified)

PARAMETER	SYMBOL	TEST CONDITIONS	MIN	TYP	MAX	UNIT
OFF CHARACTERISTICS						
Drain-Source Breakdown Voltage	BV _{DSS}	V _{GS} =0V, I _D =250μA	60			V
Drain-Source Leakage Current	I _{DSS}	V _{DS} =60V, V _{GS} =0V			10	μA
Gate-Source Leakage Current	Forward	V _{GS} =20V, V _{DS} =0V			100	nA
	Reverse	V _{GS} =-20V, V _{DS} =0V			-100	nA
ON CHARACTERISTICS						
Gate Threshold Voltage	V _{GS(TH)}	V _{DS} =V _{GS} , I _D =250μA	1.0		2.5	V
Static Drain-Source On-State Resistance	R _{DS(ON)}	V _{GS} =10V, I _D =25A		13	18	mΩ
DYNAMIC CHARACTERISTICS						
Input Capacitance	C _{ISS}			2500		pF
Output Capacitance	C _{OSS}	V _{GS} =0V, V _{DS} =25V, f=1MHz		230		pF
Reverse Transfer Capacitance	C _{RSS}			200		pF
SWITCHING CHARACTERISTICS						
Total Gate Charge	Q _G	V _{DS} =50V, V _{GS} =10V, I _D =1.3A I _G =3mA (Note1,2)		7.2		nC
Gate-Source Charge	Q _{GS}			0.4		nC
Gate-Drain Charge	Q _{GD}			0.8		nC
Turn-On Delay Time	t _{D(ON)}	V _{DS} =30V, V _{GS} =10V, I _D =50A, R _G =25Ω (Note1,2)		18		ns
Turn-On Rise Time	t _r			46		ns
Turn-Off Delay Time	t _{D(OFF)}			202		ns
Turn-Off Fall Time	t _f			116		ns
DRAIN-SOURCE DIODE CHARACTERISTICS AND MAXIMUM RATINGS						
Maximum Continuous Drain-Source Diode Forward Current	I _S				50	A
Maximum Pulsed Drain-Source Diode Forward Current	I _{SM}				150	A
Drain-Source Diode Forward Voltage	V _{SD}	I _S =50A, V _{GS} =0V			1.5	V
Body Diode Reverse Recovery Time	t _{rr}	I _S =30A, V _{GS} =0V,		50		ns
Body Diode Reverse Recovery Charge	Q _{rr}	dI _S /dt=100A/μs		80		nC

Notes: 1. Pulse Test: Pulse Width ≤ 300μs, Duty Cycle ≤ 2%.

2. Essentially independent of operating temperature.



■ MOT50N06C/D TEST CIRCUITS AND WAVEFORMS

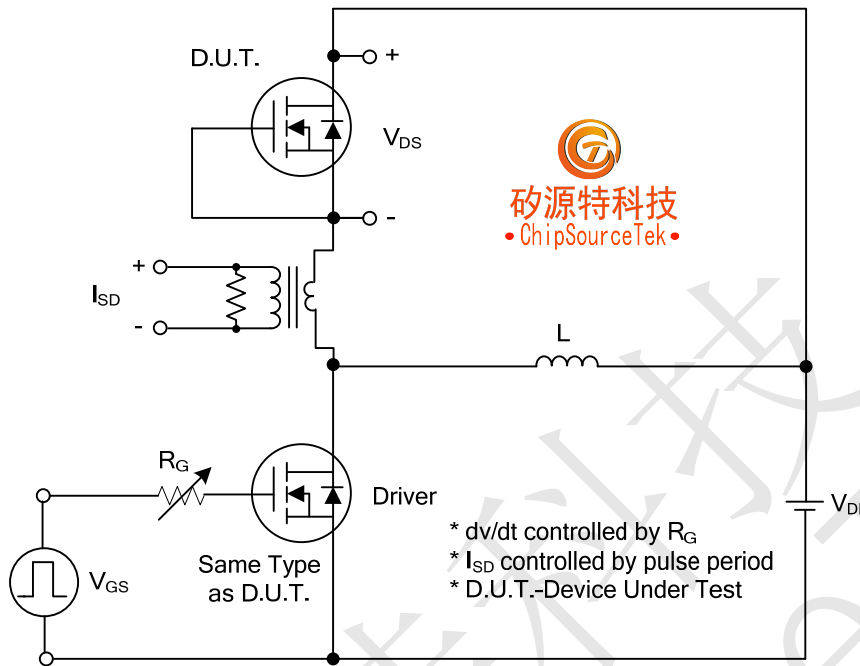

Peak Diode Recovery dv/dt Test Circuit

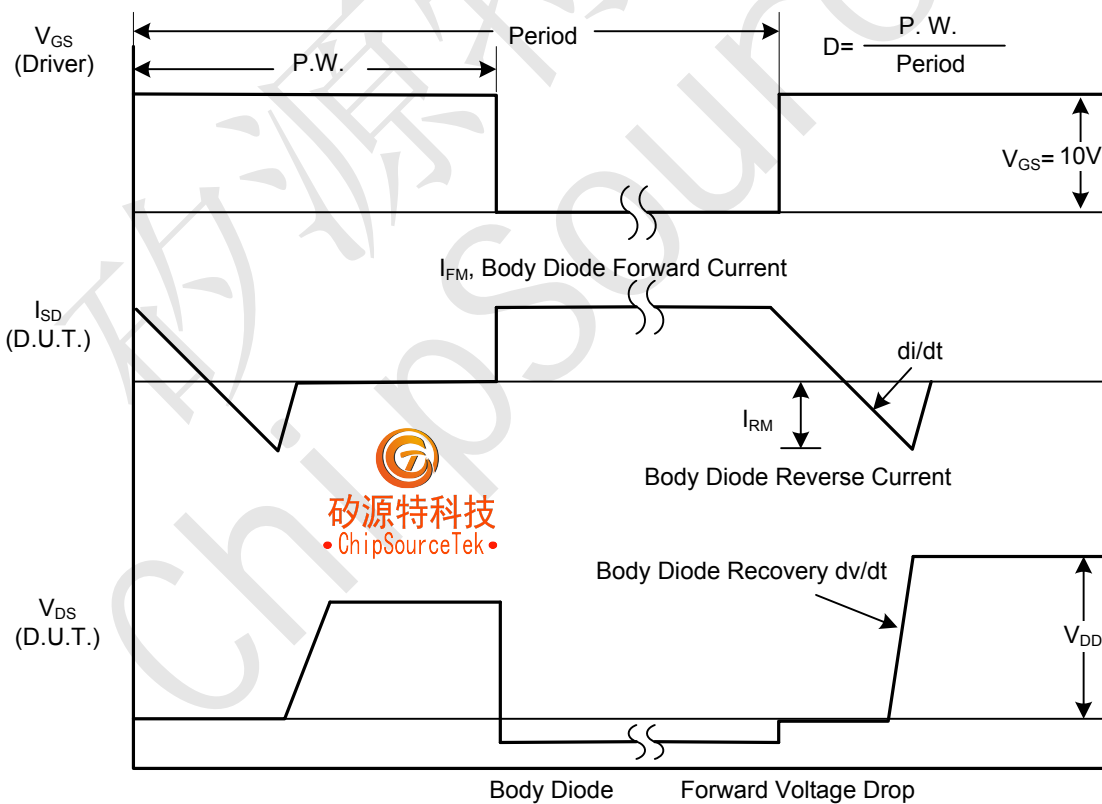

Peak Diode Recovery dv/dt Waveforms



■ MOT50N06C/D TEST CIRCUITS AND

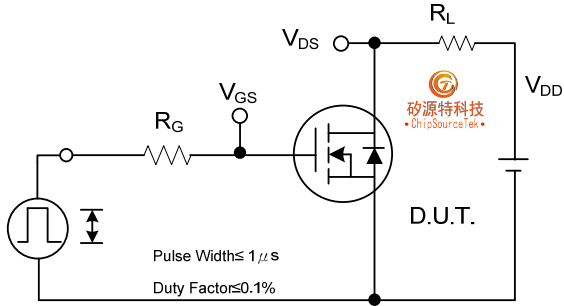

Fig. 2A Switching Test Circuit

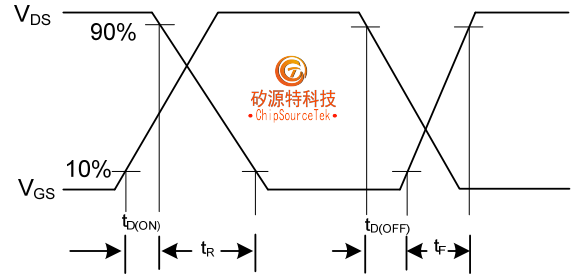

Fig. 2B Switching Waveforms

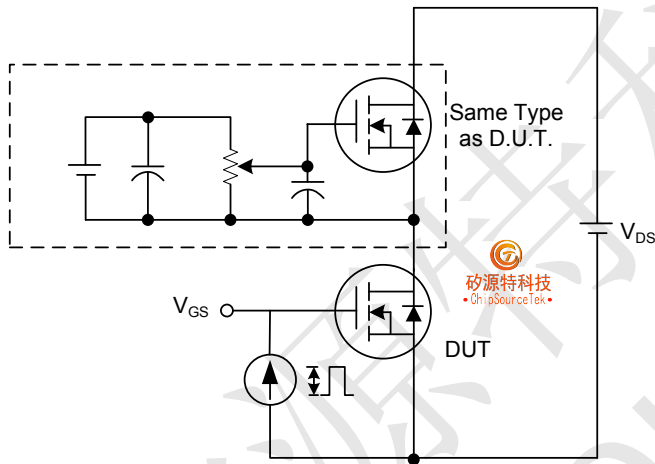

Fig. 3A Gate Charge Test Circuit

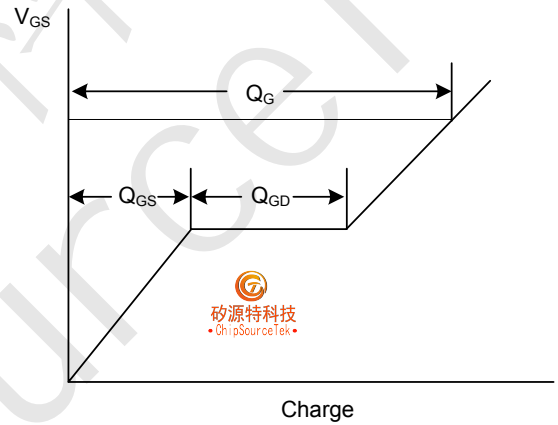

Fig. 3B Gate Charge Waveform

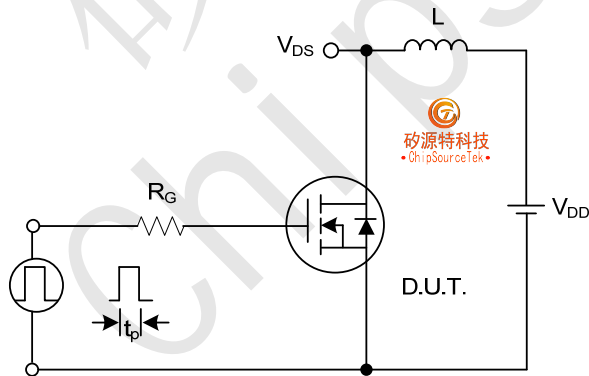

Fig. 4A Unclamped Inductive Switching Test Circuit

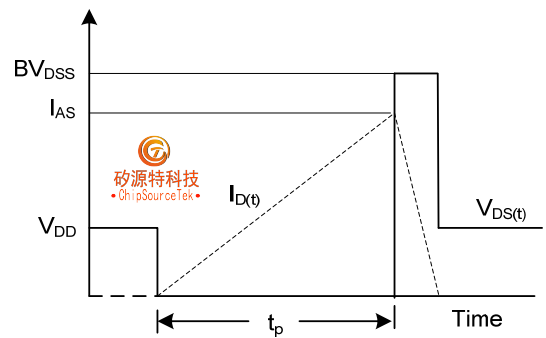
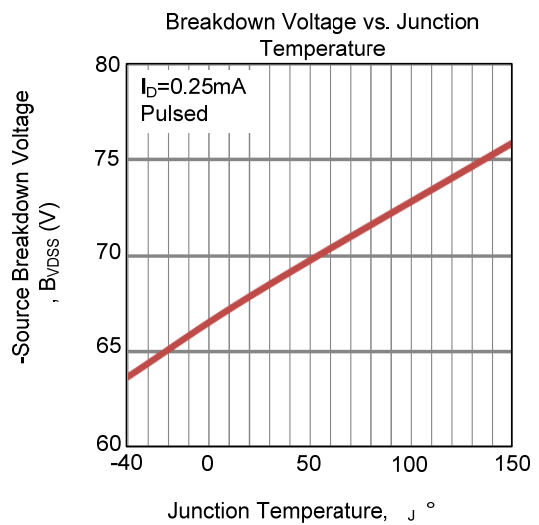
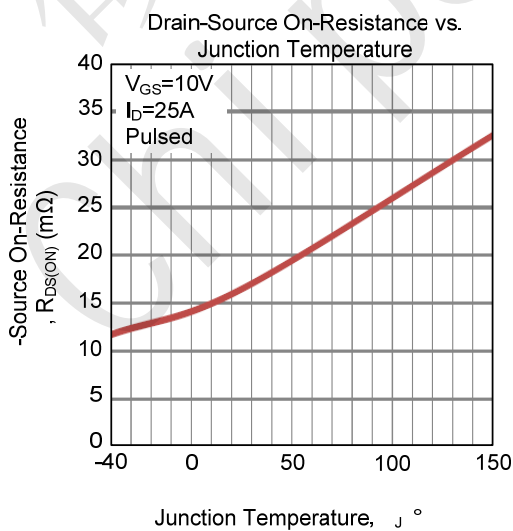
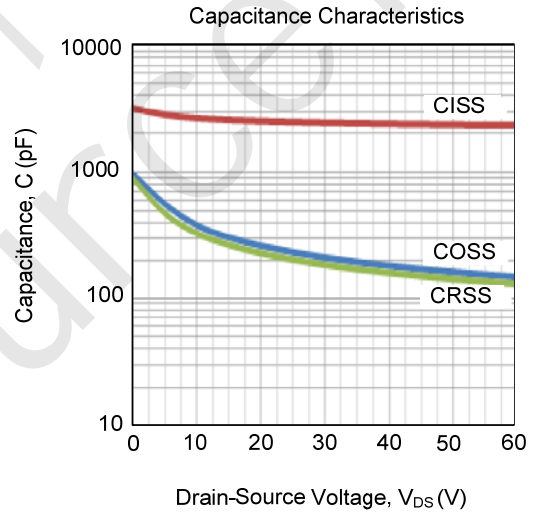
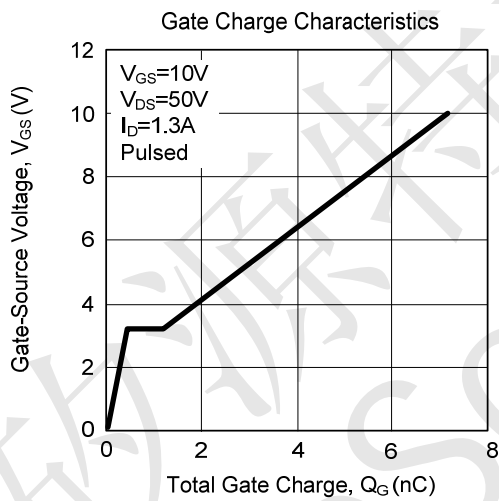
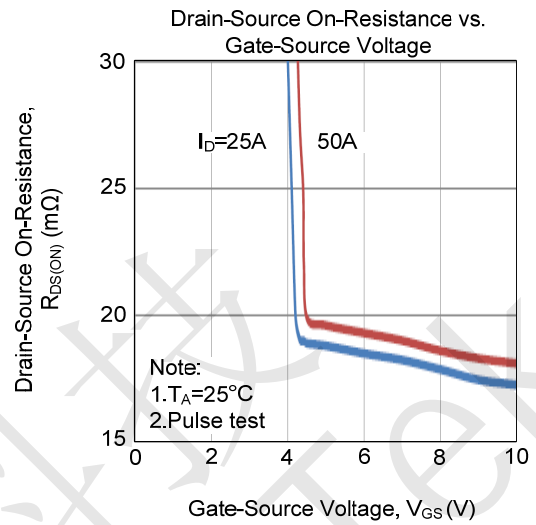
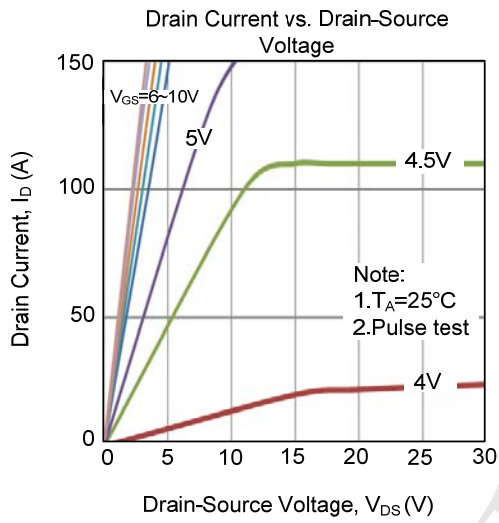

Fig. 4B Unclamped Inductive Switching Waveforms



■ MOT50N06C/D TYPICAL CHARACTERISTICS





■ MOT50N06C/D TYPICAL CHARACTERISTICS(Cont.)

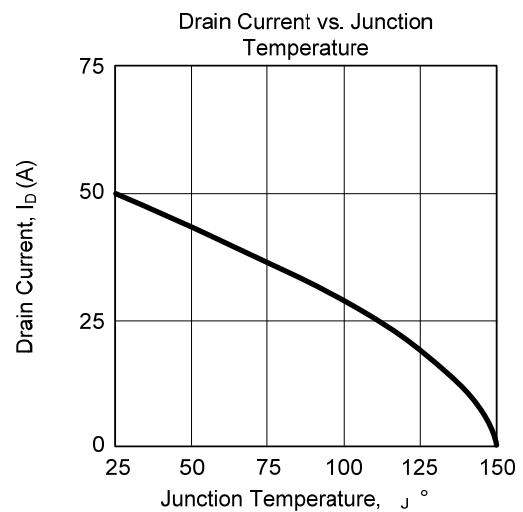
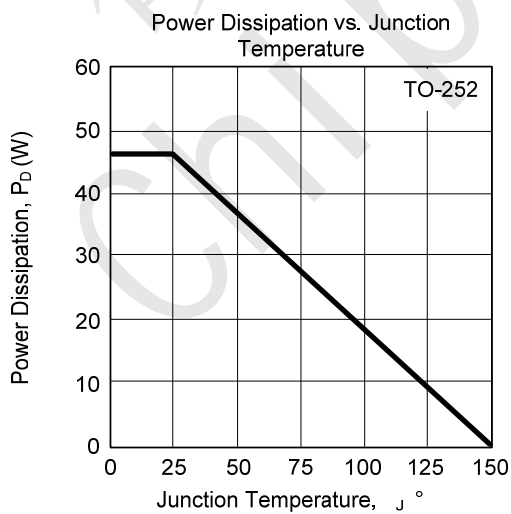
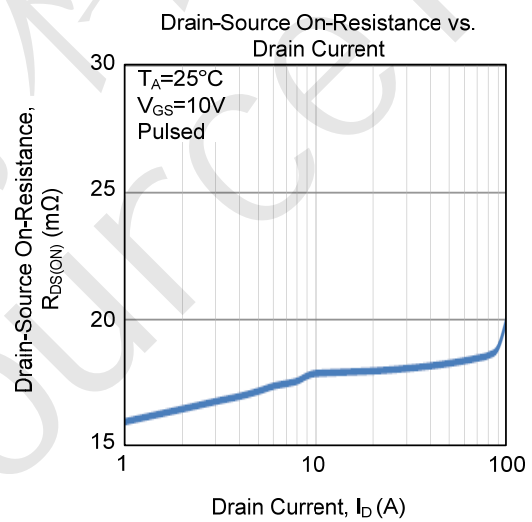
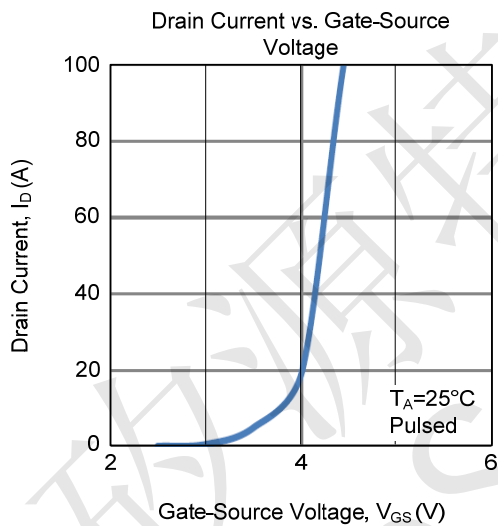
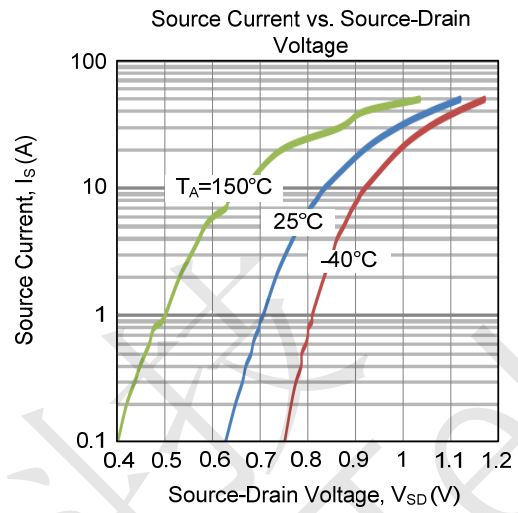
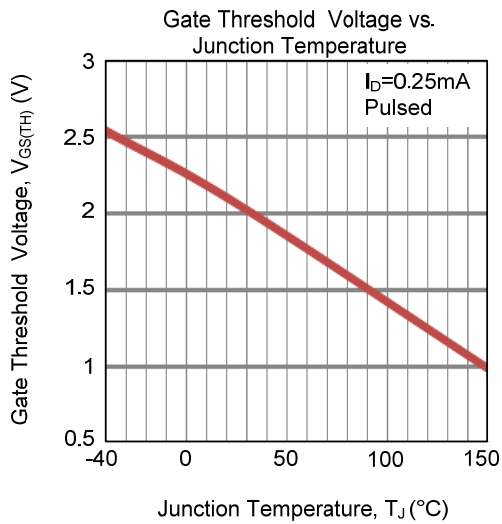



■ MOT50N06C/D TO-252 PACKAGE OUTLINE DIMENSIONS

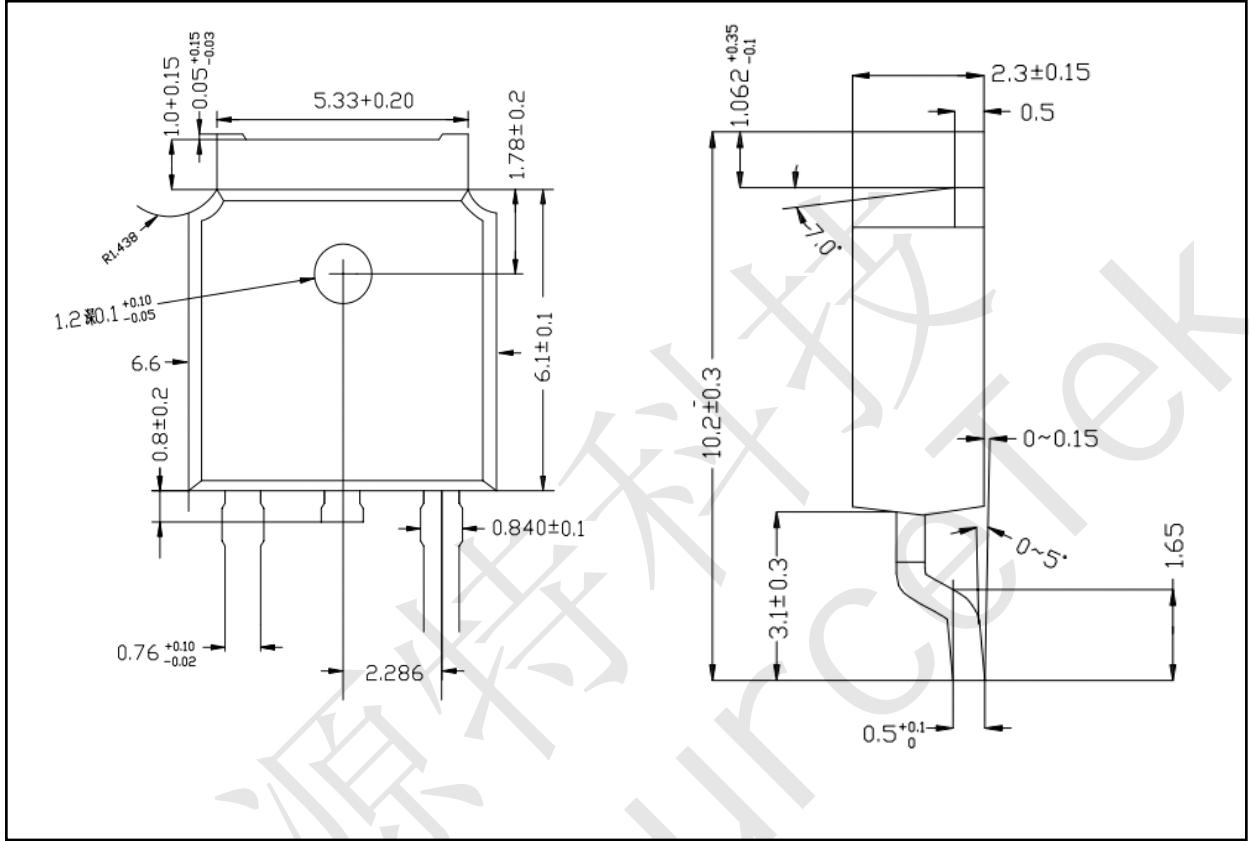



■ MOT50N06C/D TO-251 PACKAGE OUTLINE DIMENSIONS

