



## ME2149

### ULTRA-SMALL PACKAGE PWM/PFM SWITCHING CONTROL

### STEP-UP SWITCHING REGULATOR

#### General Description

The ME2149 series is a CMOS step-up switching regulator which mainly consists of a reference voltage source, an oscillation circuit, an error amplifier, a phase compensation circuit, a PWM/PFM switching control circuit. With an internal low-ON-resistance Nch Power MOS, this product is applicable to applications requiring high efficiency and high output current. The ME2149 series switches its operation to the PFM control circuit whose duty ratio is 15 % with to the PWM/PFM switching control circuit under a light load and to prevent decline in the efficiency by IC operation current.

#### Features

- Low voltage operation: Start-up is guaranteed from 0.9V( $I_{OUT} = 1 \text{ mA}$ )
- Duty ratio: Built-in PWM/PFM switching control circuit 15 to 78 % .
- oscillator frequency: 1.0MHz
- Output voltage range: <20V
- Feedback voltage accuracy:  $\pm 2\%$
- Soft start function: 2 mS

#### Applications

- MP3 players, digital audio players
- Digital cameras, GPS, wireless transceiver
- Portable devices

#### Package

- 5-pin SOT23-5、SOT89-5
- 8-pin SOP8



## Typical Application Circuit

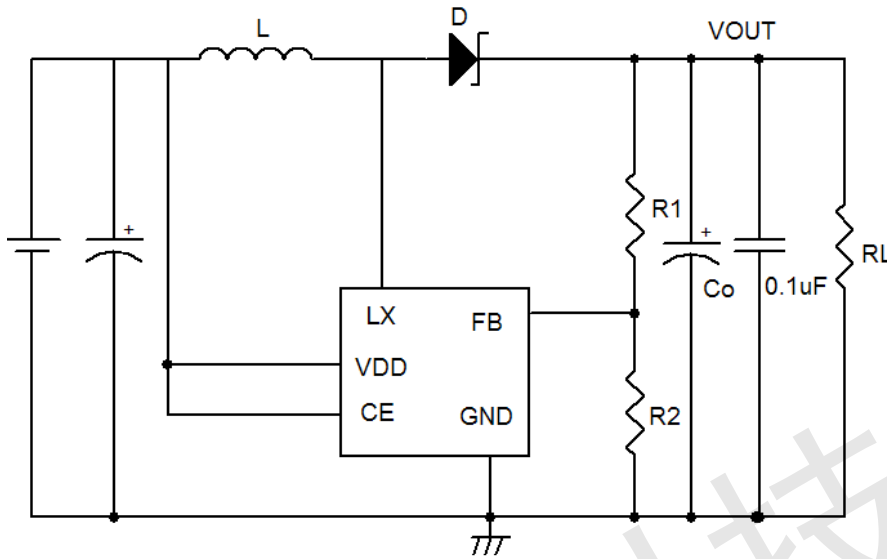

### Note:

1. This product from the start when the VDD=0.9V booster work ,but in order to stabilize the output voltage and oscillation frequency ,to control the VDD, $2.5V \leq VDD < 6V$ .
2. ME2149F has three packages, suggestion: SOT23-5 loading is not more than 1A; SOT89-5 is not more than 1.5A; SOP8 is not more than 2A.

## Selection Guide

ME 2149X X X XX G

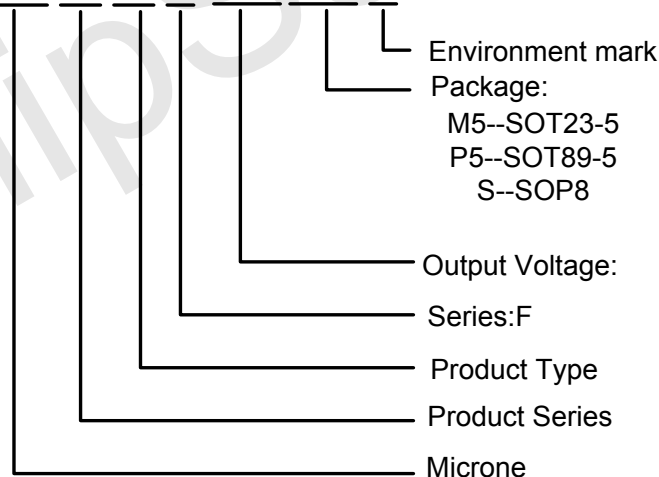

product series	posfix	package	switching transistor	CE function	VDD function	FB function	features
ME2149FxxG	M5	SOT23-5	Build in Transistor	Yes	Yes	Yes	LX+FB
	P5	SOT89-5					
	SOP8	SOP8					



## Pin Configuration

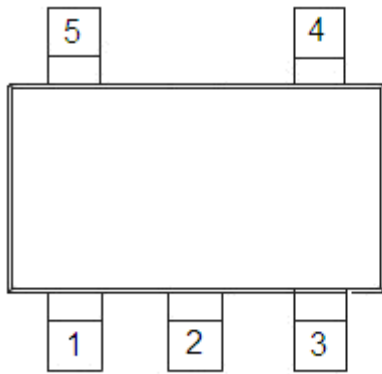

SOT23-5

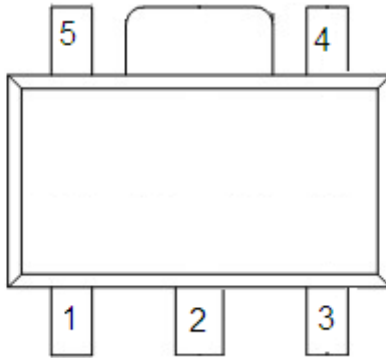

SOT89-5

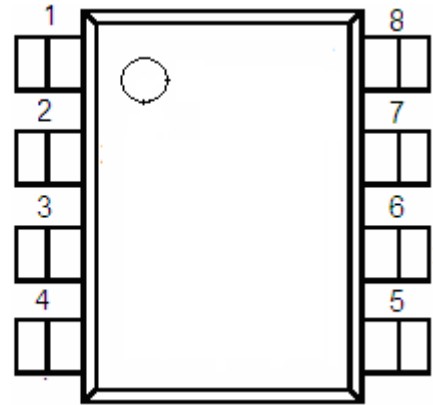

SOP8

## Pin Assignment

ME2149FxxG

Pin Number			Pin Name	Function
SOT23-5	SOT89-5	SOP8		
1	3	3	CE	Shutdown pin
2	2	7,8	LX	External transistor connection pin
3	1	2	GND	GND pin
4	5	5,6	VDD	IC power supply pin
5	4	4	FB	Feed Back voltage pin



## Block Diagram

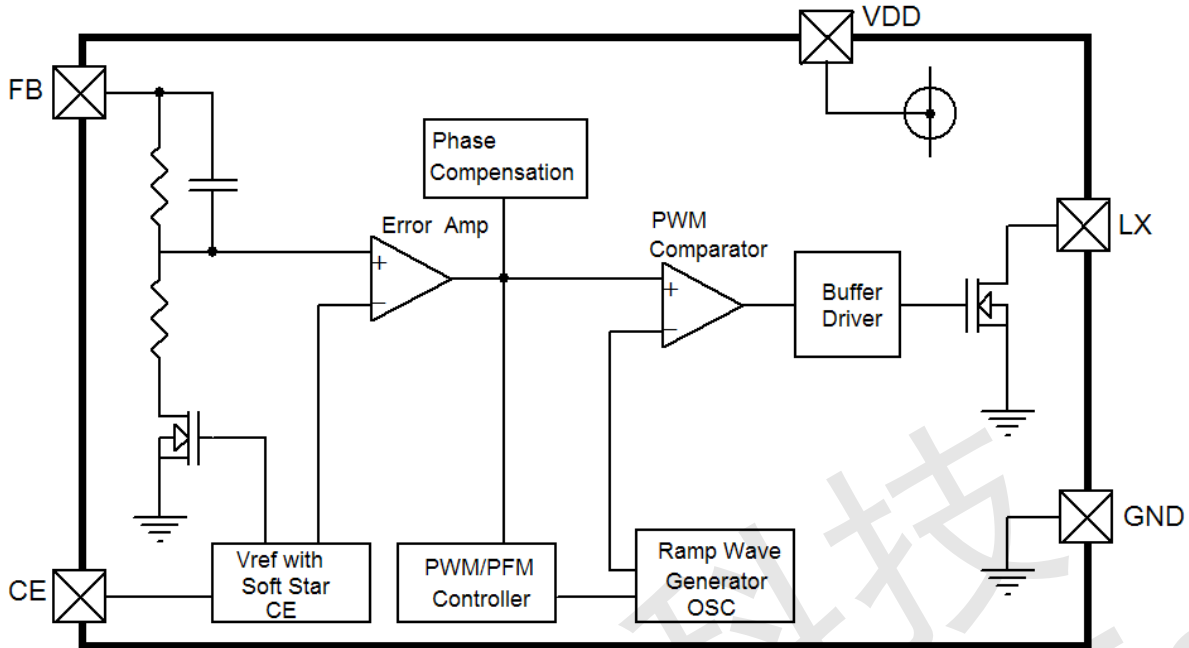

## Absolute Maximum Ranges

PARAMETER	SYMBOL	RATING		UNIT
VDD Pin Voltage	VDD	-0.3~6.5		V
LX Pin Voltage	LX	-0.3~VDD+0.3		V
CE Pin Voltage	V <sub>CE</sub>	-0.3~VDD+0.3		V
LX Pin Current	I <sub>LX</sub>	±4000		mA
Power Dissipation	Pd	SOT23-5	300	mW
		SOT89-5	500	
		SOP8	800	
Operating Temperature Range	T <sub>Opr</sub>	-25~+85		°C
Storage Temperature Range	T <sub>stg</sub>	-40~+125		°C



## Electrical Characteristics

### ME2149FxxG

Measuring conditions:  $V_{DD}=V_{CE}=3.3V$ ,  $T_{opt}=25^{\circ}C$ . Unless otherwise specified.

Parameter	SYMBOL	CONDITION	MIN	TYP	MAX	UNIT	Circuit	
Feedback voltage	$V_{FB}$	-	1.225	1.25	1.275	V	2	
Input voltage	$V_{IN}$	-	-	-	6	V	2	
Operation start voltage	$V_{ST}$	$I_{OUT}=1mA$	-	-	0.9	V	2	
Operation holding voltage	$V_{HLD}$	$I_{OUT}=1mA$ , Measured by decreasing $V_{IN}$ voltage gradually	0.7	-	-	V	2	
Current consumption 1	$I_{SS1}$	$V_{FB}=V_{FB(S)} \times 0.95$	-	4.0	-	mA	1	
Current consumption 2	$I_{SS2}$	$V_{FB}=1.5V$	-	25	-	$\mu A$	1	
Current consumption during shutdown	$I_{SSS}$	$V_{CE}=0V$	-	0.02	0.5	$\mu A$	1	
Feedback voltage temperature coefficient		$T_a=-25-85^{\circ}C$	-	$\pm 50$	-	ppm/ $^{\circ}C$	2	
Oscillation frequency	$F_{osc}$	-	0.8	1.0	1.2	MHz	1	
Max. duty ratio	MAXDUTY	$V_{FB}=V_{FB(S)} \times 0.95$	-	78	-	%	1	
PWM/PFM switching duty ratio	PFMDUTY	$V_{FB}=V_{FB(S)} \times 1.5$ , no load	-	15	-	%	1	
Shutdown pin input voltage	$V_{SH}$	Measured the oscillation at LX pin		0.75	-	-	V	1
	$V_{SL1}$	Judged the stop of oscillation at LX pin	$V_{OUT} \geq 1.5V$	-	-	0.3	V	1
	$V_{SL2}$		$V_{OUT} < 1.5V$	-	-	0.2	V	1
Shutdown pin input voltage	$I_{SH}$	$V_{CE}=V_{FB(S)} \times 0.95$		-0.1	-	0.1	$\mu A$	1
	$I_{SL}$	$V_{CE}=0V$		-0.1	-	0.1	$\mu A$	1
Soft start time	tss	-	-	2	-	mS	2	
Efficiency	EFF1	-	-	90	-	%	2	

Note:

- $V_{OUT(S)}$  is the set output voltage value, and  $V_{OUT}$  is the typical value of the output voltage.
- $V_{OUT(S)}$  can be set by using the rate of  $V_{FB}$  and output voltage setting resistors (R1, R2).
- $V_{FB(S)}$  is the set output voltage value.
- This product from the start when the  $V_{DD}=0.9V$  booster work, but in order to stabilize the output voltage and oscillation frequency, to control the  $V_{DD}$ ,  $2.5V \leq V_{DD} < 6V$ .



## Test Circuit

1.

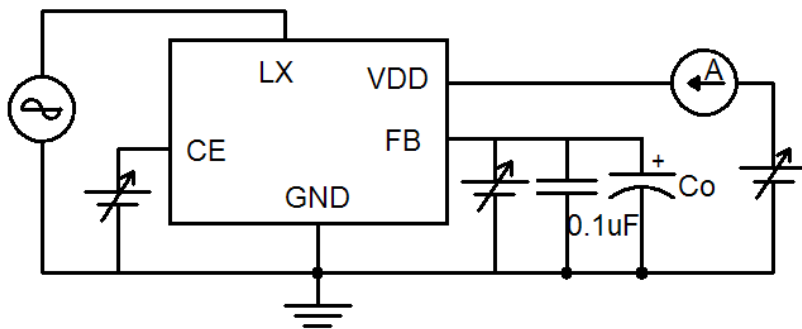

2.

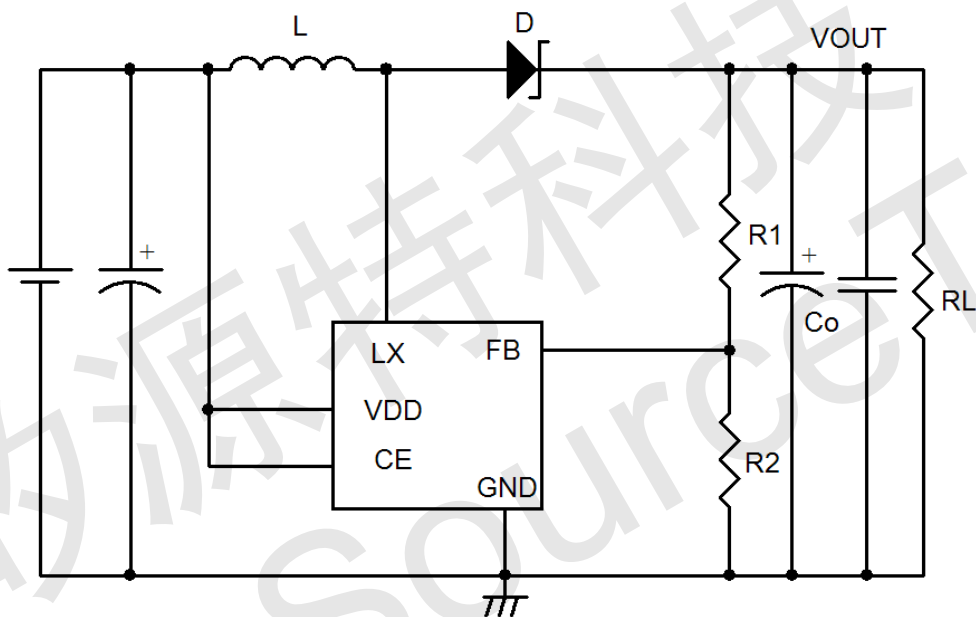

### External parts (suggest)

- 1、Diode use Schottky diode such as SS14 or SS34 (forward voltage drop: 0.2V)
- 2、Inductor: 3.3 $\mu$ H ( $r < 30\text{m}\Omega$ )
- 3、Capacitor: ceramic capacitor 22 $\mu$ F (It is best to use two parallel connection ceramic capacitors)



## External parts selection for DC/DC converter

The relationship between major characteristics of the step-up circuit and characteristics parameters of the external parts are shown in Figure 1.

<u>For larger output current?</u>	<u>For high efficiency?</u>		<u>For smaller ripple voltage?</u>
	Operation efficiency	Stand-by efficiency	
Smaller inductance	Larger inductance		
Smaller DC resistance of inductor			
Large output capacitance			Large output capacitance

Figure 1 Relationship between major characteristics of the step-up circuit and external parts

### 1. Inductor

An inductance has strong influence on maximum output current  $I_{OUT}$  and efficiency  $\eta$ .

Figure 2 shows the relation between  $I_{OUT}$ , and  $\eta$  characteristics to L of ME2149.

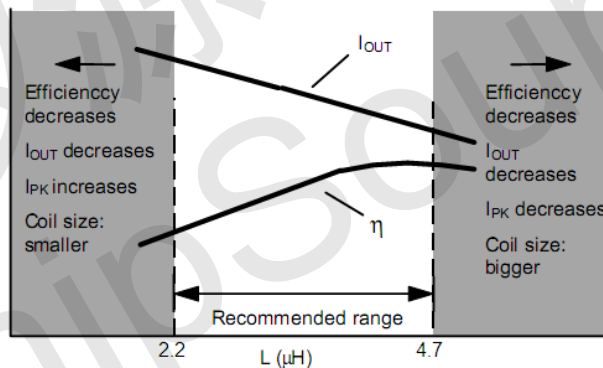

Figure 2 L— $I_{OUT}$  and  $\eta$  characteristics

The peak current ( $I_{PK}$ ) increases by decreasing L and the stability of a circuit improves and  $I_{OUT}$  increases. If L is furthermore made small, efficiency falls and in running short,  $I_{OUT}$  decreases. (Based on the current drive capability of external switching transistor.)

The loss of  $I_{PK}$  by the switching transistor decreases by increasing L and the efficiency becomes maximum at a certain L value. Further increasing L decreases efficiency due to the loss of DC resistance of the coil. Also,  $I_{OUT}$  decreases, too.

Oscillation frequency is higher, smaller one can be chose and also makes coil smaller. The recommended inductances are 2.2 to 4.7  $\mu$ H inductor for ME2149.

Choose a value for L by referring to the reference data because the maximum output current is due to the input



voltage in an actual case. Choose an inductor so that  $I_{PK}$  does not exceed the allowable current. Exceeding the allowable current of the inductor causes magnetic saturation, remarkable low efficiency and destruction of the IC chip due to a large current.

$I_{PK}$  in uncontinuous mode is calculated from the following equation:

$$I_{PK} = \sqrt{\frac{2I_{OUT}(V_{OUT} + V_D - V_{IN})}{f_{OSC} \cdot L}} (A)$$

Fosc = oscillation frequency,  $V_{DD} = 0.4 V$ .

## 2. Diode

Use an external diode that meets the following requirements:

- Low forward voltage: ( $V_F < 0.3 V$ )
- High switching speed: (50 ns max.)
- Reverse voltage:  $V_{OUT} + V_F$  or more
- Rated current:  $I_{PK}$  or more

## 3. Capacitor ( $C_{IN}$ , $C_O$ )

To improve efficiency, an input capacitor ( $C_{IN}$ ) lowers the power supply impedance and averages the input current. Select  $C_{IN}$  according to the impedance of the power supply used. The recommended capacitance is  $10\mu F$  for the ME2149.

An output capacitor ( $C_{OUT}$ ), which is used to smooth the output voltage, requires a capacitance larger than that of the step-down type because the current is intermittently supplied from the input to the output side in the step-up type. A  $22\mu F$  ceramic capacitor is recommended for the ME2149. However, a higher capacitance is recommended if the output voltage is high or the load current is large. If the output voltage or load current is low, about  $10\mu F$  can be used without problems.

Select  $C_{OUT}$  after sufficient evaluation with actual application.

A ceramic capacitor can be used for both the input and output.

## 4. Precautions

- Mount external capacitors, a diode, and a coil as close as possible to the IC.
- Unique ripple voltage and spike noise occur in switching regulators. Because they largely depend on the coil and the capacitor used, check them using an actually mounted model.
- Make sure dissipation of the switching transistor (especially at a high temperature) does not exceed the allowable power dissipation of the package.
- The performance of this IC varies depending on the design of the PCB patterns, peripheral circuits and external parts. Thoroughly test all settings with your device. Also, try to use recommended external parts.





## Typical Performance Characteristics

### Vout vs. Output Current

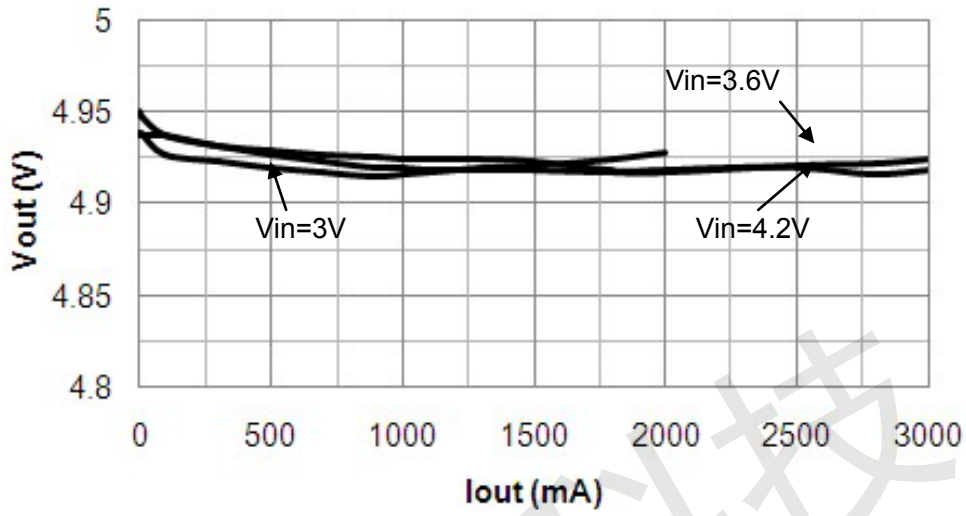

### Efficiency vs. Output Current

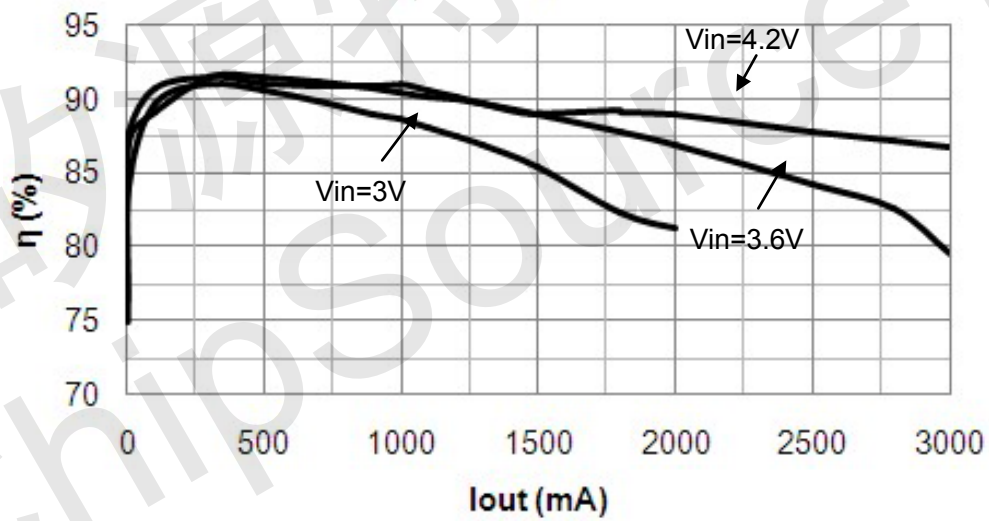



## Packaging Information

● SOT23-5

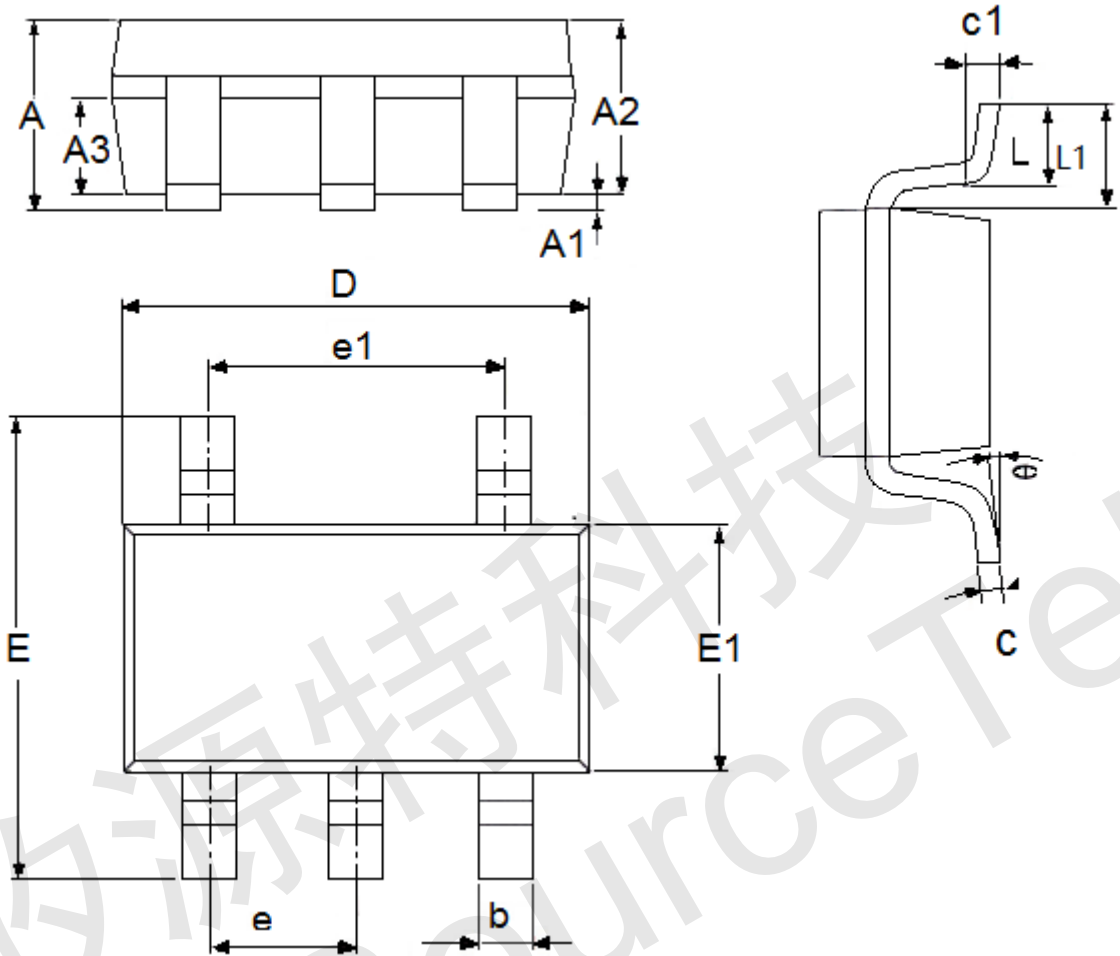

DIM	Millimeters		Inches	
	Min	Max	Min	Max
A	0.9	1.45	0.0354	0.0571
A1	0	0.15	0	0.0059
A2	0.9	1.3	0.0354	0.0512
A3	0.6	0.7	0.0236	0.0276
b	0.25	0.5	0.0098	0.0197
c	0.1	0.26	0.0039	0.0102
D	2.8	3.1	0.1102	0.122
e1	1.9(TYP)		0.0748(TYP)	
E	2.6	3.1	0.1024	0.1201
E1	1.5	1.8	0.05118113	0.07086618
e	0.95(TYP)		0.0374(TYP)	
L	0.25	0.6	0.0098	0.0236
L1	0.59(TYP)		0.0232(TYP)	
$\theta$	0	8°	0	8°
c1	0.2(TYP)		0.0079(TYP)	



● SOT89-5

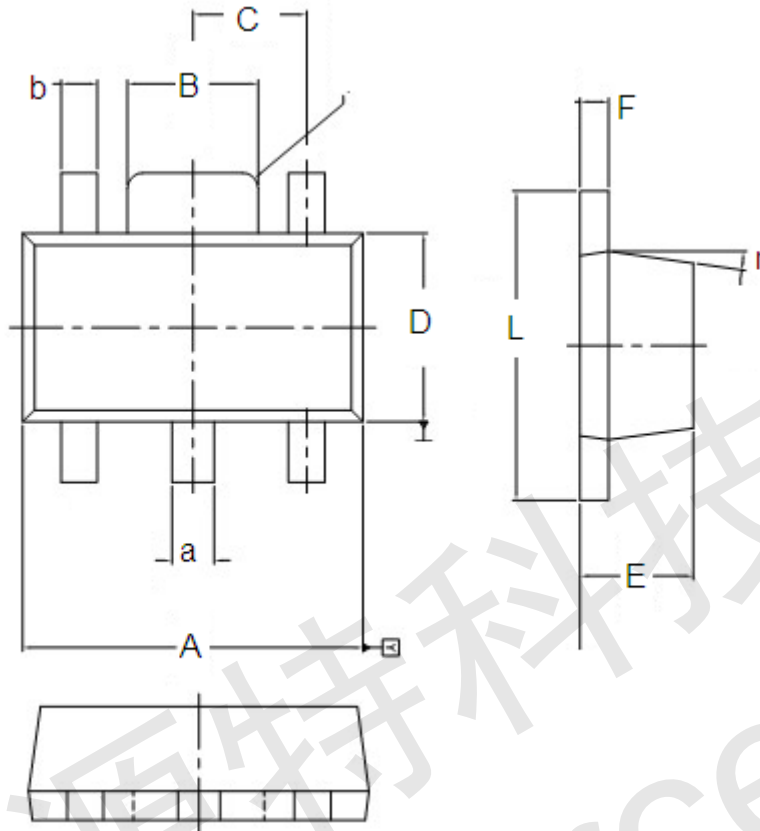

DIM	Millimeters		Inches	
	Min	Max	Min	Max
A	4.4	4.6	0.173	0.181
a	0.5	0.62	0.02	0.024
B	1.63	1.83	0.064	0.072
b	0.44	0.54	0.017	0.021
C	Type:1.5		Type:0.059	
D	2.4	2.6	0.094	0.102
E	1.4	1.6	0.054	0.063
F	0.35	0.43	0.013	0.017
L	3.95	4.25	0.155	0.167
r	Type:8 <sup>0</sup>		Type:8 <sup>0</sup>	



● SOP8

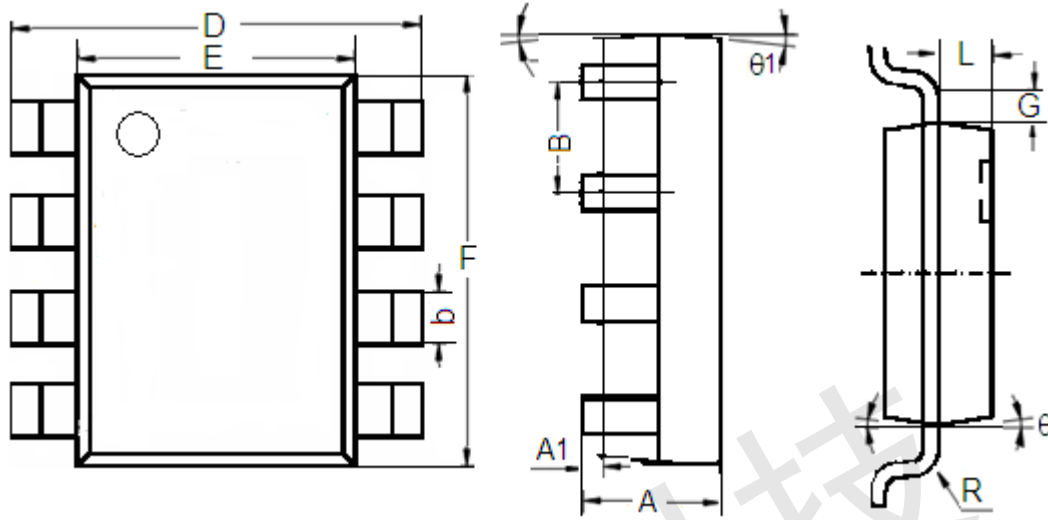

DIM	Millimeters		Inches	
	Min	Max	Min	Max
A	1.350	1.750	0.053	0.069
A1	0.1	0.3	0.004	0.012
B	1.27(Typ.)		0.05(Typ.)	
b	0.330	0.510	0.013	0.020
D	5.8	6.2	0.228	0.244
E	3.800	4.000	0.150	0.157
F	4.7	5.1	0.185	0.201
L	0.675	0.725	0.027	0.029
G	0.32(Typ.)		0.013(Typ.)	
R	0.15(Typ.)		0.006(Typ.)	
theta1	7°		7°	
theta	8°		8°	