



### CST90N02F N-Ch 20V Fast Switching MOSFETs

- ★ 100% EAS Guaranteed
- ★ Green Device Available
- ★ Super Low Gate Charge
- ★ Excellent CdV/dt effect decline
- ★ Advanced high cell density Trench technology

#### CST90N02F Product Summary



BVDSS	RDSON	ID
20V	2.7mΩ	90A

#### CST90N02F Description

The CST90N02F is the high cell density trenched N-ch MOSFETs, which provide excellent RDSON and gate charge for most of the synchronous buck converter applications. The CST90N02F meet the RoHS and Green Product requirement, 100% EAS guaranteed with full function reliability approved.

#### CST90N02F PDFN5060-8L Pin Configuration



#### CST90N02F Absolute Maximum Ratings

Symbol	Parameter	Rating	Units
$V_{DS}$	Drain-Source Voltage	20	V
$V_{GS}$	Gate-Source Voltage	$\pm 20$	V
$I_D@T_C=25^\circ C$	Continuous Drain Current, $V_{GS} @ 10V^1$	90	A
$I_D@T_C=100^\circ C$	Continuous Drain Current, $V_{GS} @ 10V^1$	59	A
$I_{DM}$	Pulsed Drain Current <sup>2</sup>	360	A
EAS	Single Pulse Avalanche Energy <sup>3</sup>	118	mJ
$I_{AS}$	Avalanche Current	41	A
$P_D@T_C=25^\circ C$	Total Power Dissipation <sup>4</sup>	88	W
$T_{STG}$	Storage Temperature Range	-55 to 150	$^\circ C$
$T_J$	Operating Junction Temperature Range	-55 to 150	$^\circ C$

#### CST90N02F Thermal Data

Symbol	Parameter	Typ.	Max.	Unit
$R_{\theta JC}$	Thermal Resistance Junction-Case <sup>1</sup>	---	1.8	$^\circ C/W$



### CST90N02F N-Ch 20V Fast Switching MOSFETs

#### CST90N02F Electrical Characteristics (T<sub>J</sub>=25°C unless otherwise specified)

Symbol	Parameter	Test Condition	Min.	Typ.	Max.	Units
<b>Off Characteristic</b>						
V <sub>(BR)DSS</sub>	Drain-Source Breakdown Voltage	V <sub>GS</sub> =0V, I <sub>D</sub> =250μA	20	-	-	V
I <sub>DSS</sub>	Zero Gate Voltage Drain Current	V <sub>DS</sub> =20V, V <sub>GS</sub> =0V	-	-	1	μA
I <sub>GSS</sub>	Gate to Body Leakage Current	V <sub>GS</sub> = ±12V, V <sub>DS</sub> =0V	-	-	±100	nA
<b>On Characteristics</b>						
V <sub>GS(th)</sub>	Gate Threshold Voltage	V <sub>DS</sub> =V <sub>GS</sub> , I <sub>D</sub> =250μA	0.4	0.7	1.0	V
R <sub>DS(on)</sub>	Static Drain-Source On-Resistance <small>note3</small>	V <sub>GS</sub> =4.5V, I <sub>D</sub> =30A	-	2.7	3.5	mΩ
		V <sub>GS</sub> =2.5V, I <sub>D</sub> =20A	-	4	5.2	
<b>Dynamic Characteristics</b>						
C <sub>iss</sub>	Input Capacitance	V <sub>DS</sub> =10V, V <sub>GS</sub> =0V, f=1.0MHz	-	3200	-	pF
C <sub>oss</sub>	Output Capacitance		-	460	-	pF
C <sub>rss</sub>	Reverse Transfer Capacitance		-	445	-	pF
Q <sub>g</sub>	Total Gate Charge	V <sub>DS</sub> =10V, I <sub>D</sub> =30A, V <sub>GS</sub> =4.5V	-	48	-	nC
Q <sub>gs</sub>	Gate-Source Charge		-	3.6	-	nC
Q <sub>gd</sub>	Gate-Drain("Miller") Charge		-	19	-	nC
<b>Switching Characteristics</b>						
t <sub>d(on)</sub>	Turn-On Delay Time	V <sub>DS</sub> =10V, I <sub>D</sub> =30A, R <sub>G</sub> =1.8Ω, V <sub>GS</sub> =4.5V	-	9.7	-	ns
t <sub>r</sub>	Turn-On Rise Time		-	37	-	ns
t <sub>d(off)</sub>	Turn-Off Delay Time		-	63	-	ns
t <sub>f</sub>	Turn-Off Fall Time		-	52	-	ns
<b>Drain-Source Diode Characteristics and Maximum Ratings</b>						
I <sub>S</sub>	Maximum Continuous Drain to Source Diode Forward Current		-	-	90	A
I <sub>SM</sub>	Maximum Pulsed Drain to Source Diode Forward Current		-	-	360	A
V <sub>SD</sub>	Drain to Source Diode Forward Voltage	V <sub>GS</sub> =0V, I <sub>SD</sub> =30A, T <sub>J</sub> =25°C	-	-	1.2	V
t <sub>rr</sub>	Reverse Recovery Time	T <sub>J</sub> =25°C, I <sub>F</sub> =30A,	-	23	-	ns
Q <sub>rr</sub>	Reverse Recovery Charge	di/dt =100A/μs	-	10	-	nC

Notes:1. Repetitive Rating: Pulse Width Limited by Maximum Junction Temperature

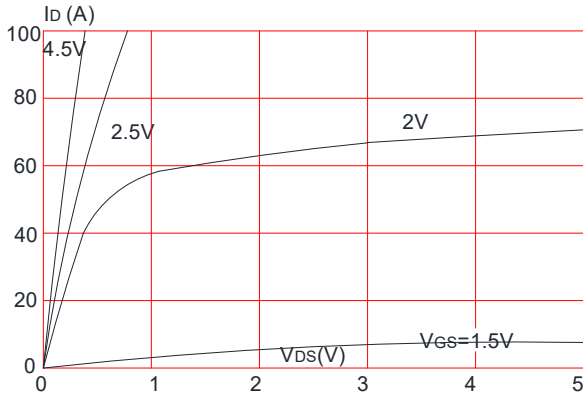
2. EAS condition: T<sub>J</sub>=25°C, V<sub>DD</sub>=15V, V<sub>G</sub>=4.5V, R<sub>G</sub>=25Ω, L=0.5mH, I<sub>AS</sub>=21A

3. Pulse Test: Pulse Width≤300μs, Duty Cycle≤0.5%

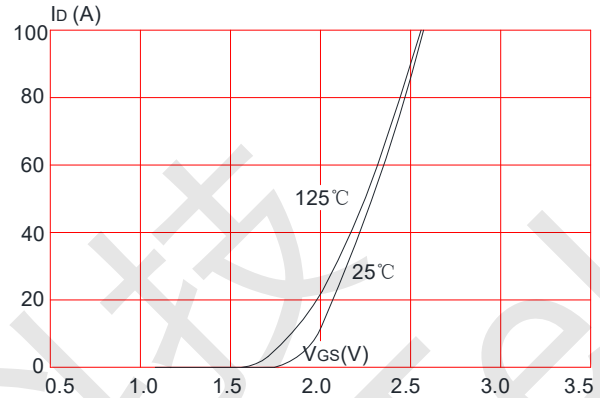


## CST90N02F Typical Performance Characteristics

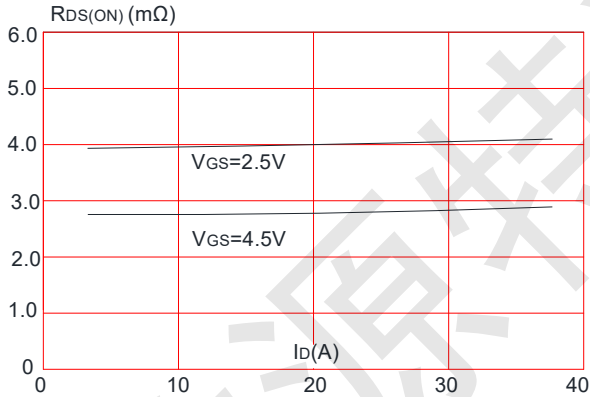
**Figure 1: Output Characteristics**



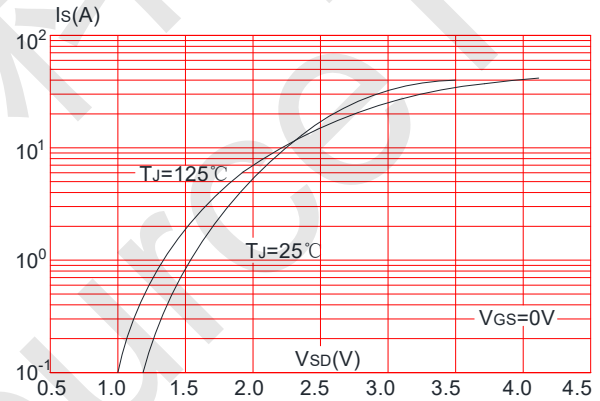
**Figure 2: Typical Transfer Characteristics**



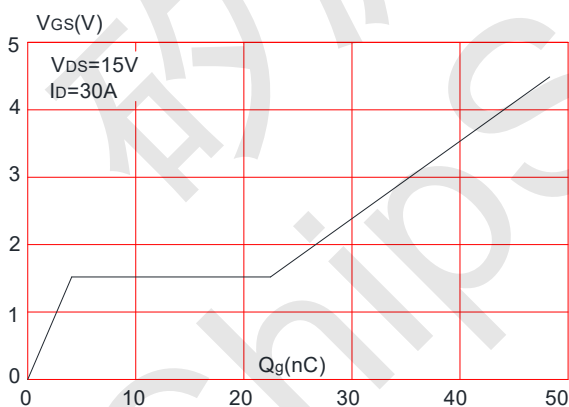
**Figure 3: On-resistance vs. Drain Current**



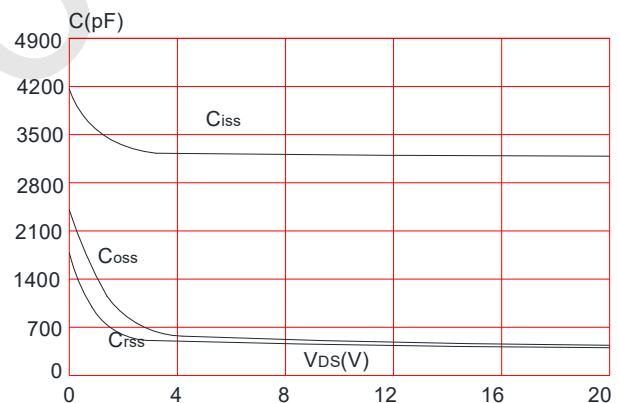
**Figure 4: Body Diode Characteristics**



**Figure 5: Gate Charge Characteristics**



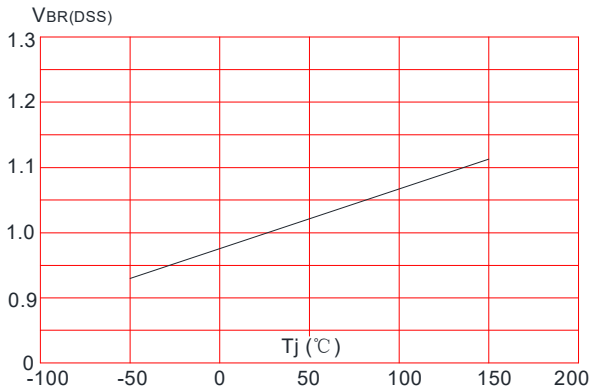
**Figure 6: Capacitance Characteristics**



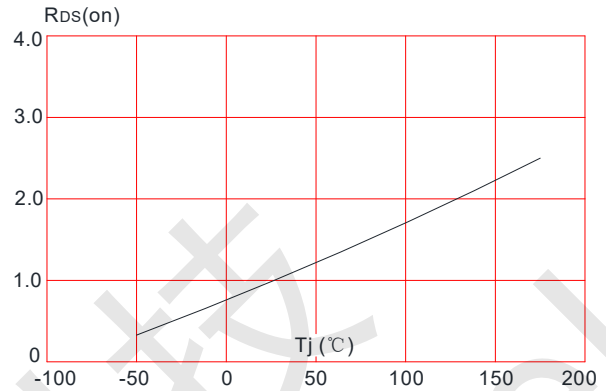


### CST90N02F N-Ch 20V Fast Switching MOSFETs

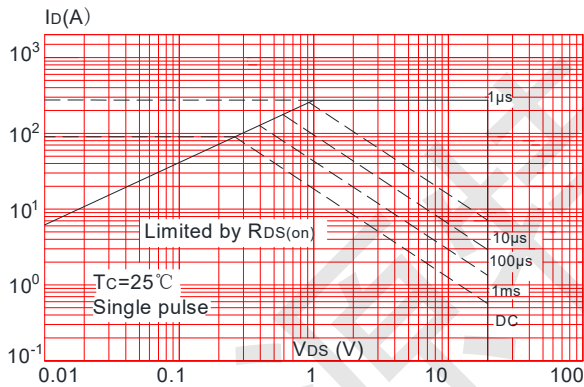
**Figure 7:** Normalized Breakdown Voltage vs. Junction Temperature



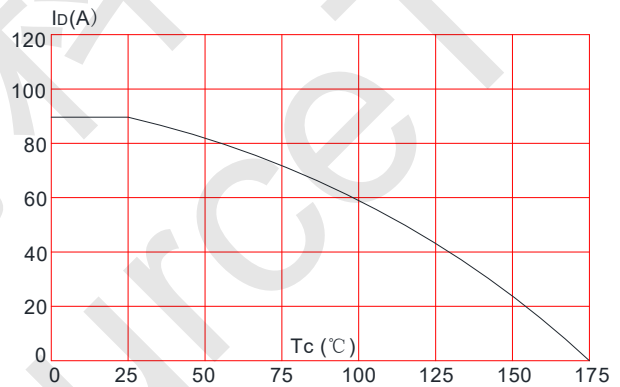
**Figure 8:** Normalized on Resistance vs. Junction Temperature



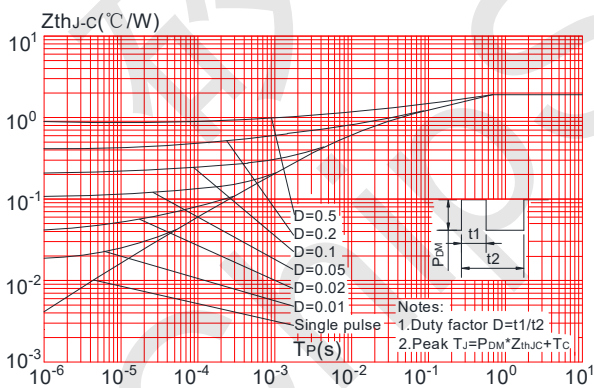
**Figure 9:** Maximum Safe Operating Area



**Figure 10:** Maximum Continuous Drain Current vs. Case Temperature

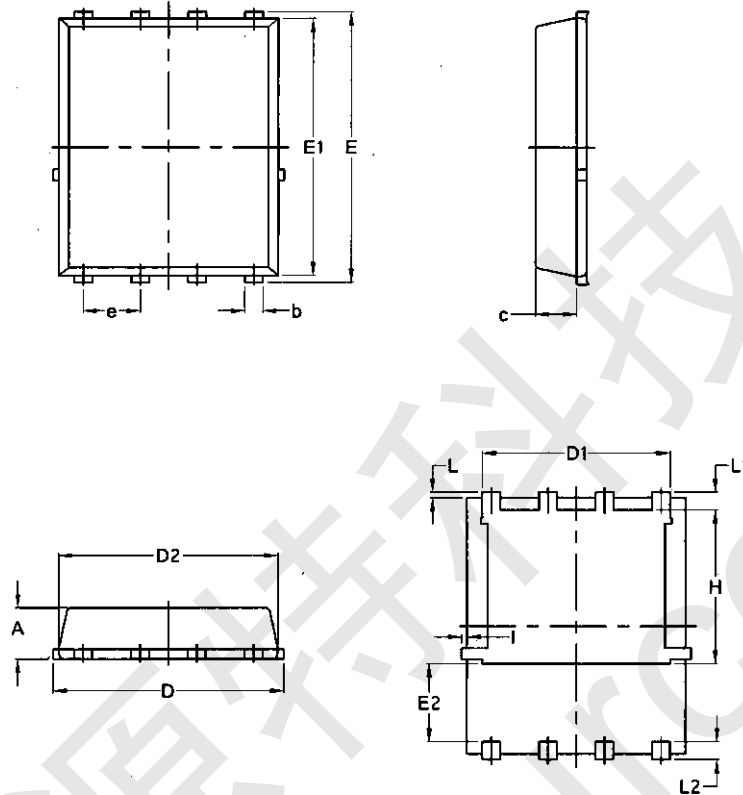


**Figure.11:** Maximum Effective Transient Thermal Impedance, Junction-to-Case





CST90N02F Package Mechanical Data-PDFN5060-8L-Single



Symbol	Common			
	mm		Inch	
	Min	Max	Min	Max
A	1.03	1.17	0.0406	0.0461
b	0.34	0.48	0.0134	0.0189
c	0.824	0.0970	0.0324	0.082
D	4.80	5.40	0.1890	0.2126
D1	4.11	4.31	0.1618	0.1697
D2	4.80	5.00	0.1890	0.1969
E	5.95	6.15	0.2343	0.2421
E1	5.65	5.85	0.2224	0.2303
E2	1.60	/	0.0630	/
e	1.27 BSC		0.05 BSC	
L	0.05	0.25	0.0020	0.0098
L1	0.38	0.50	0.0150	0.0197
L2	0.38	0.50	0.0150	0.0197
H	3.30	3.50	0.1299	0.1378
I	/	0.18	/	0.0070