



CST70P03D P-Ch 30V Fast Switching MOSFETs

- ★ 100% EAS Guaranteed
- ★ Green Device Available
- ★ Super Low Gate Charge
- ★ Excellent CdV/dt effect decline
- ★ Advanced high cell density Trench technology



CST70P03D Product Summary

BVDSS	RDSON	ID
-30V	6.5mΩ	-65A

CST70P03D Description

The CST70P03D is the high cell density trenched P-ch MOSFETs, which provide excellent RDSON and gate charge for most of the synchronous buck converter applications.

The CST70P03D meet the RoHS and Gree Product requirement 100% EAS guaranteed with full function reliability approved.

CST70P03D PDFN3333-8L Pin Configuration

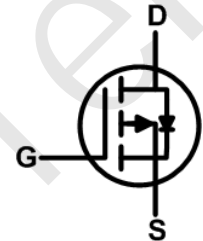
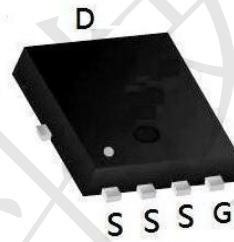

CST70P03D Absolute Maximum Ratings

Parameter	Symbol	Value	Unit	
Drain-Source Voltage	V_{DS}	-30	V	
Gate-Source Voltage	V_{GS}	±20	V	
Continuous Drain Current@-10V ¹	$T_C=25^{\circ}C$	-65	A	
	$T_C=75^{\circ}C$	-35		
Pulsed Drain Current ²	I_{DM}	-175	A	
Single Pulse Avalanche Energy ³	EAS	31	mJ	
Avalanche Current	I_{AS}	-70	A	
Total Power Dissipation ⁴	$T_C=25^{\circ}C$	P_D	31.2	W
Operating Junction and Storage Temperature Range	T_J, T_{STG}	-55 to+150	°C	

CST70P03D Thermal Characteristics

Parameter	Symbol	Value	Unit
Thermal Resistance from Junction-to-Ambient ¹	$R_{\theta JA}$	61	°C/W
Thermal Resistance from Junction-to-Case ¹	$R_{\theta JC}$	4	°C/W



CST70P03D P-Ch 30V Fast Switching MOSFETs

CST70P03D Electrical Characteristics T_c = 25°C, unless otherwise noted

Parameter	Symbol	Test Conditions	Min.	Typ.	Max.	Unit
Static Characteristics						
Drain-Source Breakdown Voltage	V_{(BR)DSS}	V _{GS} = 0V, I _D = -250μA	-30	-	-	V
Gate-body Leakage current	I_{GSS}	V _{DS} = 0V, V _{GS} = ±20V	-	-	±100	nA
Zero Gate Voltage Drain Current	T _J =25°C	V _{DS} = -24V, V _{GS} = 0V	-	-	-1	μA
	T _J =55°C		-	-	-5	
Gate-Threshold Voltage	V_{GS(th)}	V _{DS} = V _{GS} , I _D = -250μA	-1.0	-1.6	-2.5	V
Drain-Source On-Resistance ²	R_{DS(on)}	V _{GS} = -10V, I _D = -12A	-	6.5	9.3	mΩ
		V _{GS} = -4.5V, I _D = -8A	-	9.5	14.5	
Forward Transconductance	g_{fs}	V _{DS} = -5V, I _D = -20A	-	28	-	S
Dynamic Characteristics						
Input Capacitance	C_{iss}	V _{DS} = -15V, V _{GS} = 0V, f = 1MHz	-	4320	-	pF
Output Capacitance	C_{oss}		-	529	-	
Reverse Transfer Capacitance	C_{rss}		-	487	-	
Switching Characteristics						
Gate Resistance	R_g	V _{DS} = 0V, V _{GS} = 0V, f = 1.0MHz	-	4.0	-	Ω
Total Gate Charge	Q_g	V _{GS} = -10V, V _{DS} = -15V, I _D = -15A	-	45	-	nC
Gate-Source Charge	Q_{gs}		-	8.5	-	
Gate-Drain Charge	Q_{gd}		-	12.8	-	
Turn-On Delay Time	t_{d(on)}		-	18.9	-	
Rise Time	t_r	V _{GS} = -10V, V _{DD} = -15V, R _G = 2.5Ω, I _D = -15A	-	15.7	-	
Turn-Off Delay Time	t_{d(off)}		-	64.8	-	
Fall Time	t_f		-	36.5	-	
Drain-Source Body Diode Characteristics						
Diode Forward Voltage ²	V_{SD}	I _S = -1A, V _{GS} = 0V	-	-	-1	V
Continuous Source Current ^{1,5}	I_S	V _G =V _D =0V, Force Current	-	-	-65	A

Note :

1. The data tested by surface mounted on a 1 inch² FR-4 board with 2OZ copper.
2. The data tested by pulsed, pulse width ≤ 300us, duty cycle ≤ 2%
3. The EAS data shows Max. rating. The test condition is V_{DD} = -25V, V_{GS} = -10V, L = 0.1mH, I_{AS} = -25A
4. The power dissipation is limited by 150°C junction temperature
5. The data is theoretically the same as I_D and I_{DM}, in real applications, should be limited by total power dissipation.



CST70P03D P-Ch 30V Fast Switching MOSFETs

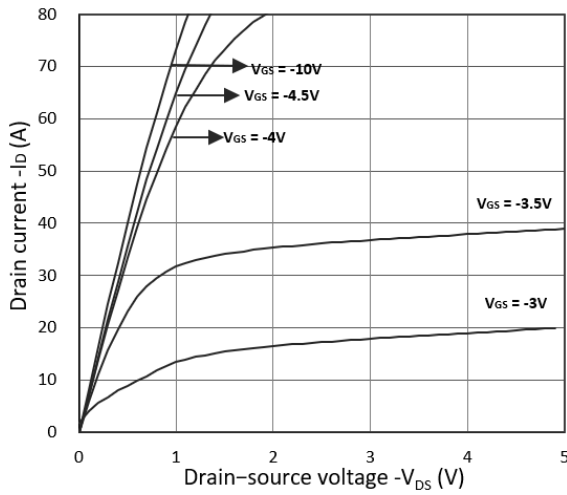

Figure 1. Output Characteristics

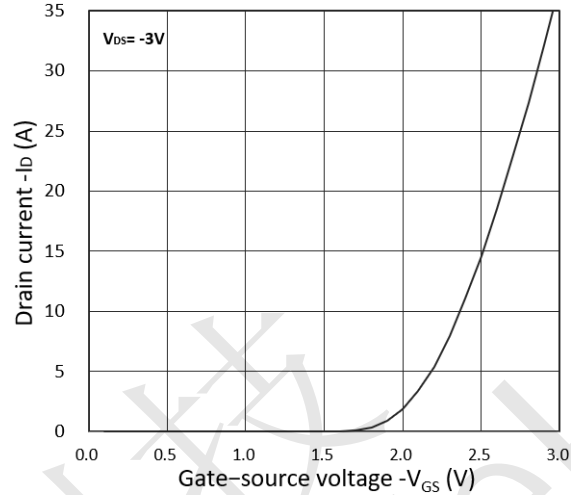

Figure 2. Transfer Characteristics

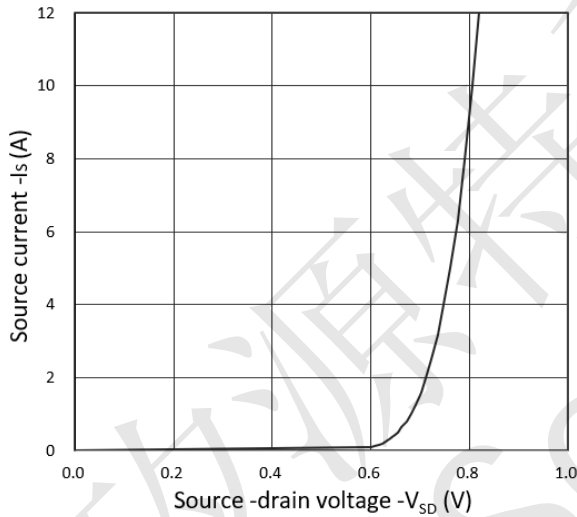

Figure 3. Forward Characteristics of Reverse

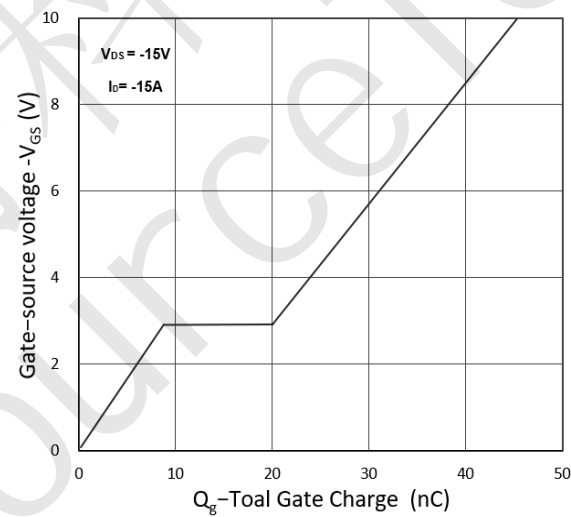

Figure 4. Gate Charge Characteristics

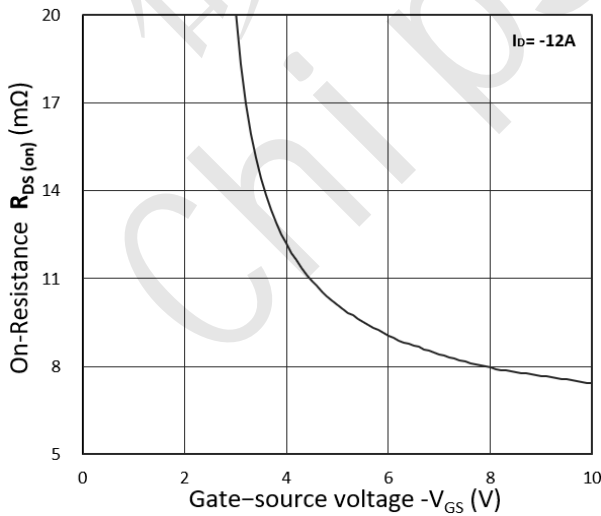

Figure 5. $R_{DS(on)}$ vs. V_{GS}

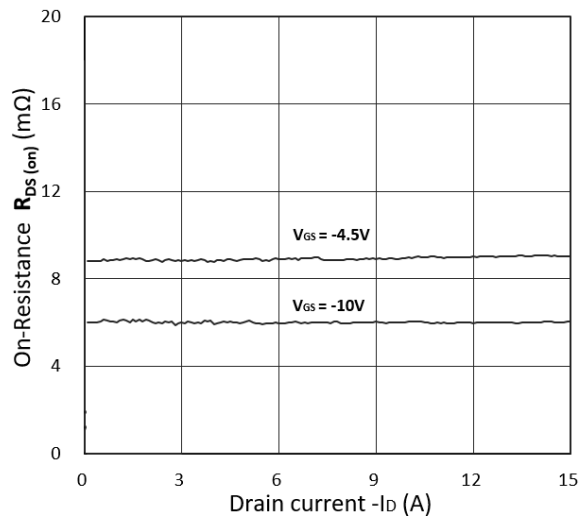

Figure 6. $R_{DS(on)}$ vs. I_D



CST70P03D P-Ch 30V Fast Switching MOSFETs

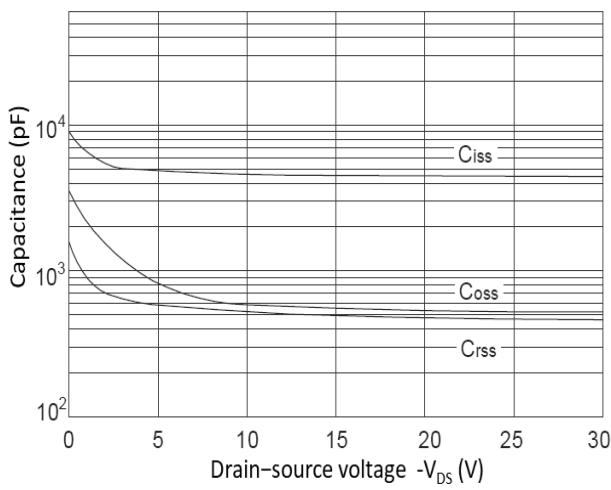

Figure 7. Capacitance Characteristics

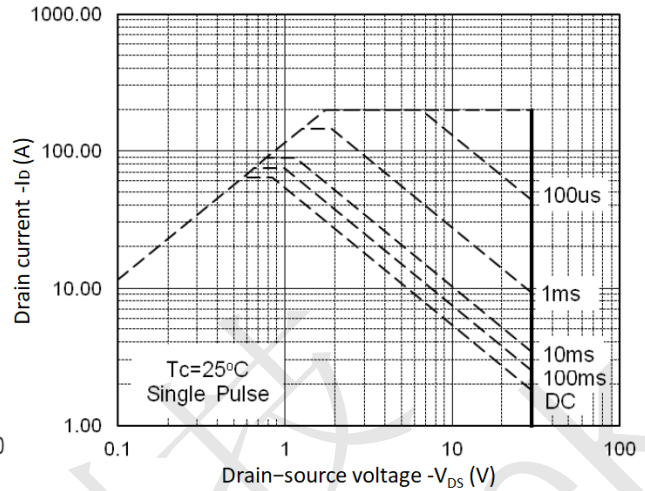

Figure 8. Safe Operating Area

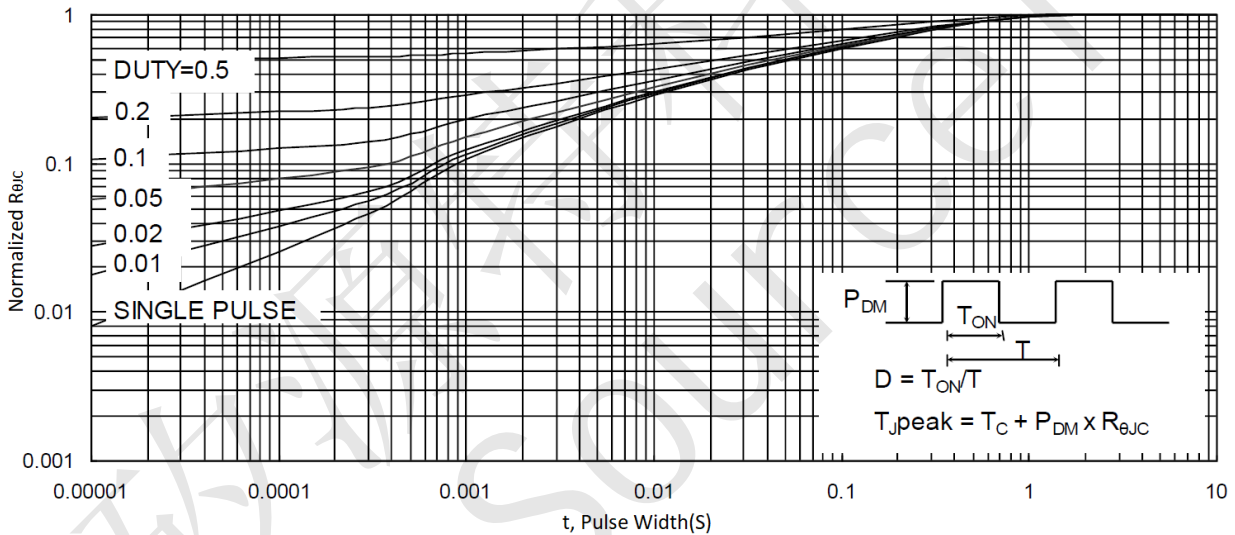

Figure 9. Normalized Maximum Transient Thermal Impedance

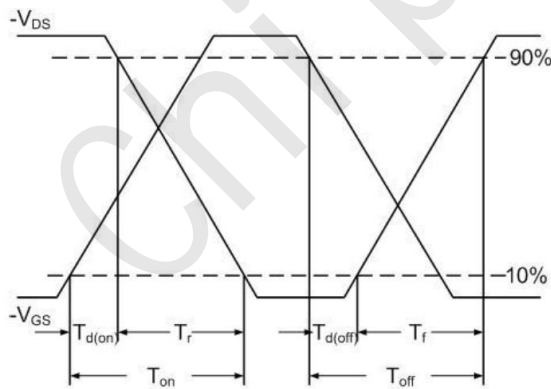

Figure 10. Switching Time Waveform

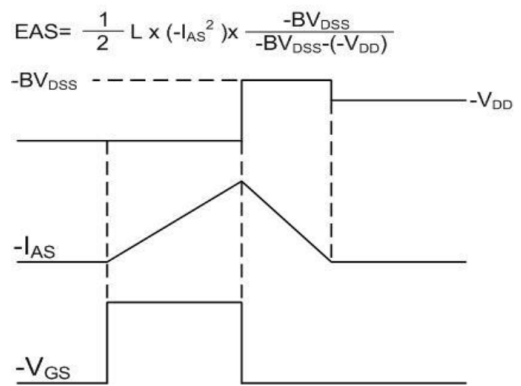
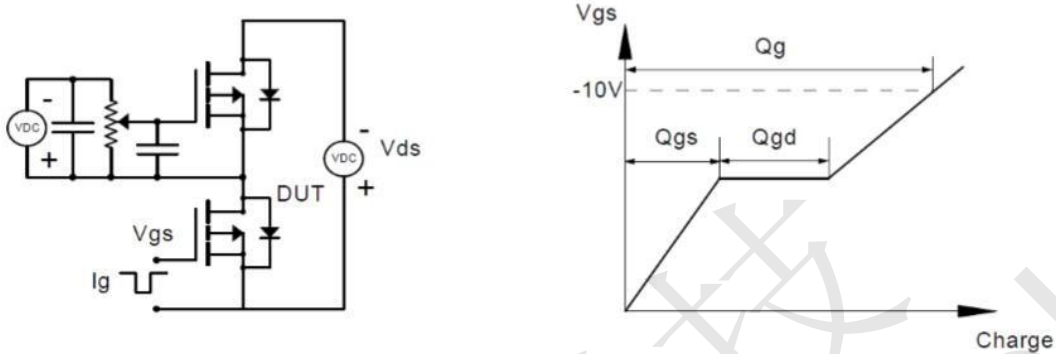

Figure 11. Unclamped Inductive Switching Waveform



CST70P03D Test Circuit

Gate Charge Test Circuit & Waveform



Resistive Switching Test Circuit & Waveforms

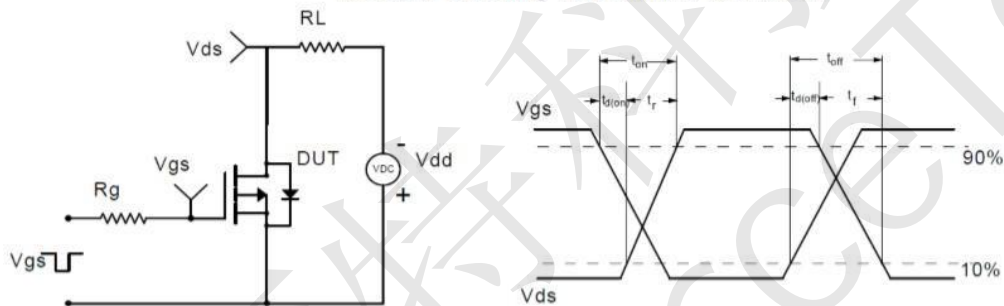

Unclamped Inductive Switching (UIS) Test Circuit & Waveforms

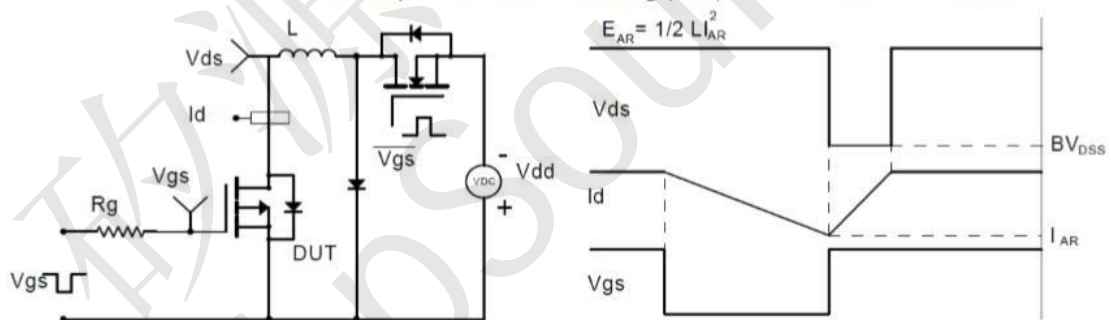

Diode Recovery Test Circuit & Waveforms

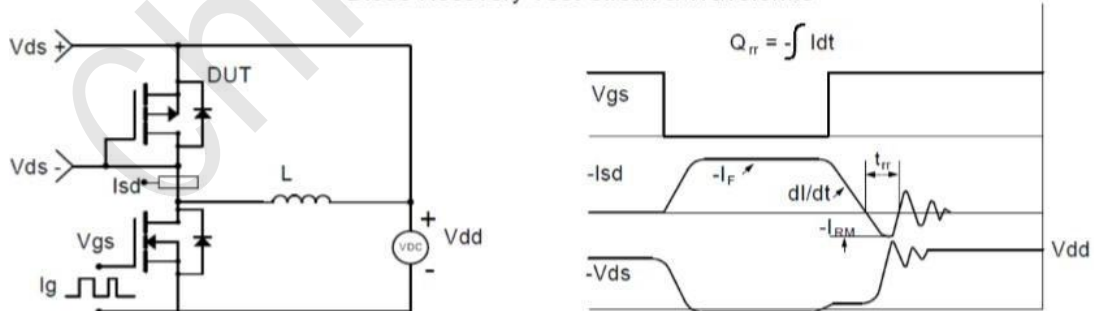



CST70P03D Package Mechanical Data-PDFN3333-8L-Single

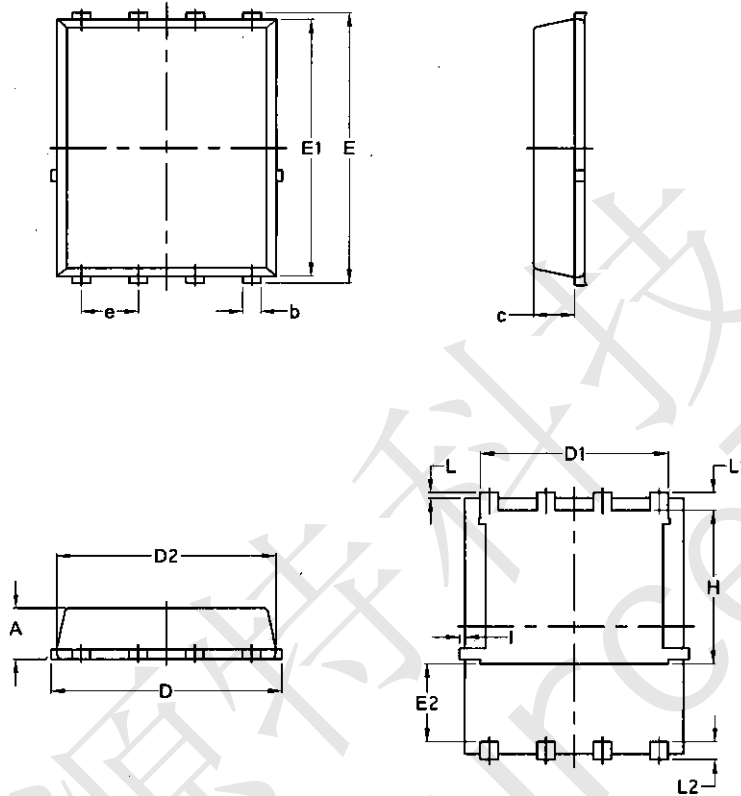

COMMON DIMENSIONS

(UNITS OF MEASURE=MILLIMETER)

SYMBOL	MIN	NOM	MAX
A	0.70	0.80	0.90
A1	0.00	0.03	0.05
b	0.24	0.30	0.35
c	0.10	0.15	0.20
D	3.25	3.32	3.40
D1	3.05	3.15	3.25
D2	2.40	2.50	2.60
E	3.00	3.10	3.20
E1	1.35	1.45	1.55
e	0.65 BSC.		
H	3.20	3.30	3.40
L	0.30	0.40	0.50
L1	0.10	0.15	0.20
L2	1.13 REF.		