



CST70P03 P-Ch 30V Fast Switching MOSFETs

- ★ 100% EAS Guaranteed
- ★ Green Device Available
- ★ Super Low Gate Charge
- ★ Excellent CdV/dt effect decline
- ★ Advanced high cell density Trench technology

CST70P03 Product Summary



| BVDSS | RDSON | ID |
|-------|-------|------|
| -30V | 7.5mΩ | -65A |

CST70P03 Description

The CST70P03 is the highest performance trench P-ch MOSFETs with extreme high cell density, which provide excellent RDSON and gate charge for most of the synchronous buck converter applications.

The CST70P03 meet the RoHS and Green Product requirement, 100% EAS guaranteed with full function reliability approved.

CST70P03 TO252 Pin Configuration

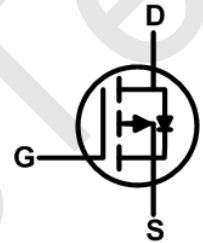
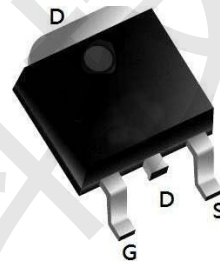

CST70P03 Absolute Maximum Ratings (TA = 25°C, unless otherwise noted)

| Parameter | Symbol | Value | Unit |
|--|-----------------------------------|-----------------------|------|
| Drain-Source Voltage | V _{DS} | -30 | V |
| Gate-Source Voltage | V _{GS} | ±20 | V |
| Continuous Drain Current | I _D | T _C =25°C | -65 |
| | | T _C =100°C | -32 |
| Pulsed Drain Current ¹ | I _{DM} | -200 | A |
| Single Pulse Avalanche Energy ² | EAS | 80 | mJ |
| Total Power Dissipation | P _D | 43.1 | W |
| Operating Junction and Storage Temperature Range | T _J , T _{STG} | -55 to 150 | °C |

CST70P03 Thermal Characteristics

| Parameter | Symbol | Value | Unit |
|--|------------------|-------|------|
| Thermal Resistance from Junction-to-Ambient ³ | R _{θJA} | 70 | °C/W |
| Thermal Resistance from Junction-to-Case | R _{θJC} | 2.9 | °C/W |



CST70P03 Electrical Characteristics (T_J = 25°C, unless otherwise noted)

| Parameter | Symbol | Test Conditions | Min. | Typ. | Max. | Unit | |
|--|----------------------|--|-----------------------|------|------|------|----|
| Static Characteristics | | | | | | | |
| Drain-Source Breakdown Voltage | V _{(BR)DSS} | V _{GS} = 0V, I _D = -250μA | -30 | - | - | V | |
| Gate-body Leakage current | I _{GSS} | V _{DS} = 0V, V _{GS} = ±20V | - | - | ±100 | nA | |
| Zero Gate Voltage Drain Current | I _{DSS} | V _{DS} = -30V, V _{GS} = 0V | T _J =25°C | - | - | -1 | μA |
| | | | T _J =100°C | - | - | -100 | |
| Gate-Threshold Voltage | V _{GS(th)} | V _{DS} = V _{GS} , I _D = -250μA | -1 | -1.5 | -2.5 | V | |
| Drain-Source on-Resistance ⁴ | R _{DS(on)} | V _{GS} = -10V, I _D = -15A | - | 7.5 | 14 | mΩ | |
| | | V _{GS} = -4.5V, I _D = -10A | - | 10.5 | 22 | | |
| Forward Transconductance ⁴ | g _{fs} | V _{DS} = -10V, I _D = -15A | - | 44 | - | S | |
| Dynamic Characteristics⁵ | | | | | | | |
| Input Capacitance | C _{iss} | V _{DS} = -15V, V _{GS} = 0V, f = 1MHz | - | 2503 | - | pF | |
| Output Capacitance | C _{oss} | | - | 315 | - | | |
| Reverse Transfer Capacitance | C _{rss} | | - | 279 | - | | |
| Gate Resistance | R _g | f = 1MHz | - | 10.5 | - | Ω | |
| Switching Characteristics⁵ | | | | | | | |
| Total Gate Charge | Q _g | V _{GS} = -10V, V _{DS} = -15V, I _D = -15A | - | 30 | - | nC | |
| Gate-Source Charge | Q _{gs} | | - | 5 | - | | |
| Gate-Drain Charge | Q _{gd} | | - | 7.5 | - | | |
| Turn-on Delay Time | t _{d(on)} | V _{GS} = -10V, V _{DD} = -15V, R _G = 2.5Ω, I _D = -15A | - | 14.1 | - | ns | |
| Rise Time | t _r | | - | 20 | - | | |
| Turn-off Delay Time | t _{d(off)} | | - | 94 | - | | |
| Fall Time | t _f | | - | 65 | - | | |
| Drain-Source Body Diode Characteristics | | | | | | | |
| Diode Forward Voltage ⁴ | V _{SD} | I _S = -1A, V _{GS} = 0V | - | - | -1.2 | V | |
| Continuous Source Current | I _S | T _C = 25°C | - | - | -65 | A | |

Notes:

1. Repetitive rating, pulse width limited by junction temperature T_{J(MAX)} = 150°C.
2. The EAS data shows Max. rating . The test condition is V_{DD} = -25V, L = 0.1mH, I_{AS} = -40A.
3. The data tested by surface mounted on a 1 inch² FR-4 board with 2OZ copper, The value in any given application depends on the user's specific board design.
4. The data tested by pulsed , pulse width ≤ 300us , duty cycle ≤ 2%.
5. This value is guaranteed by design hence it is not included in the production test.



CST70P03 Typical Characteristics

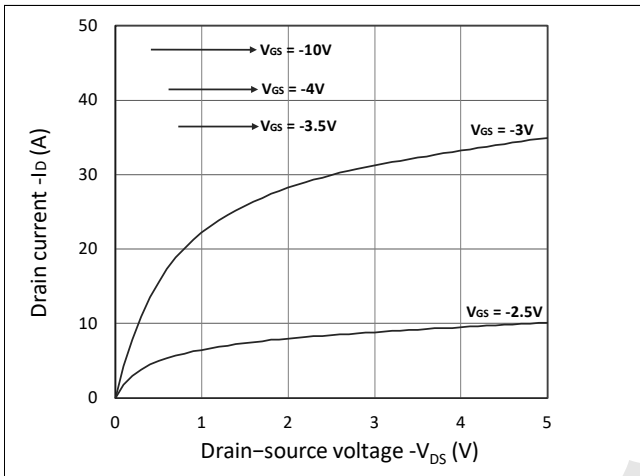

Figure 1. Output Characteristics

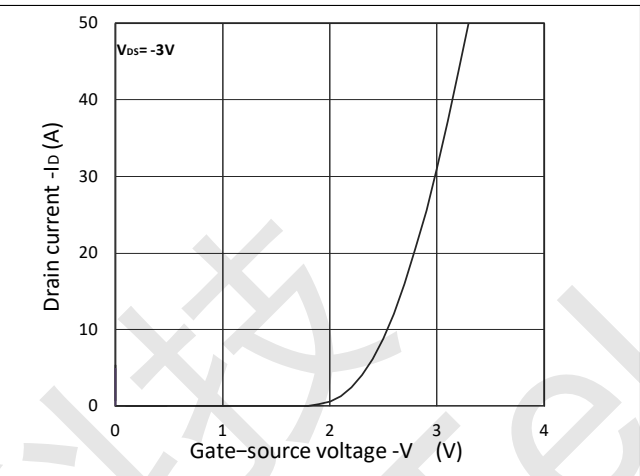

Figure 2. Transfer Characteristics

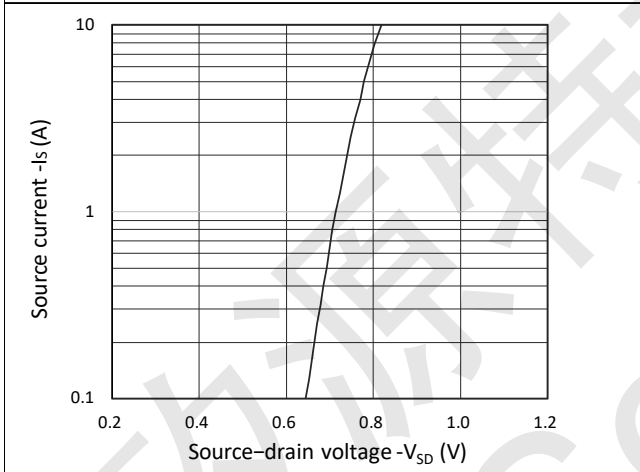

Figure 3. Forward Characteristics of Reverse

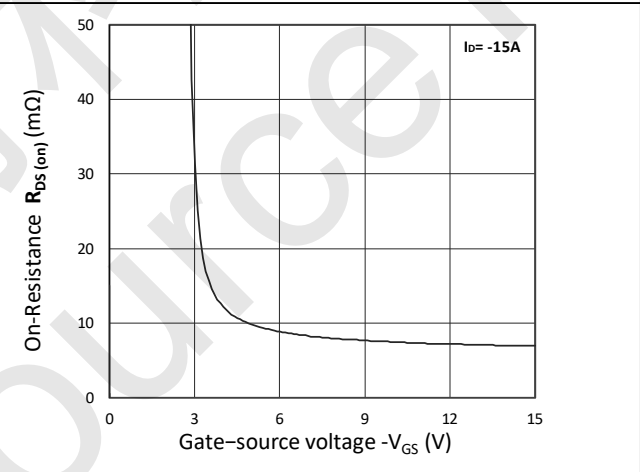

Figure 4. $R_{DS(ON)}$ vs. V_{GS}

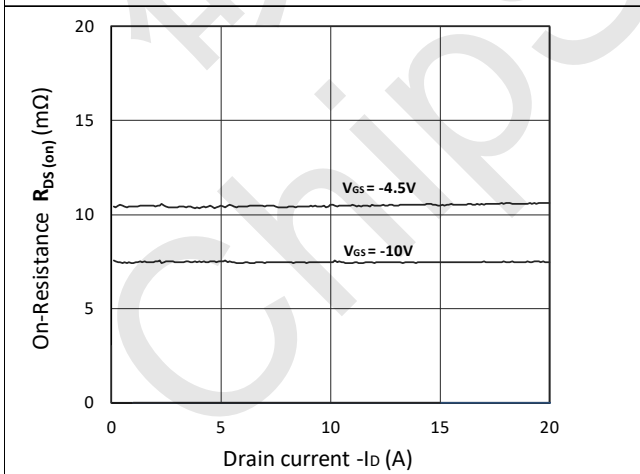

Figure 5. $R_{DS(ON)}$ vs. I_D

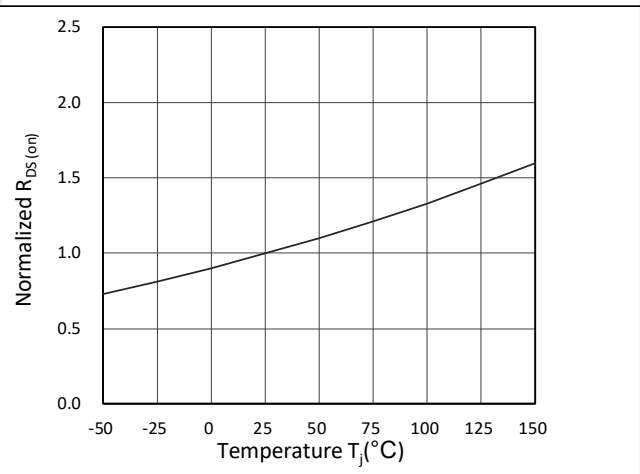

Figure 6. Normalized $R_{DS(ON)}$ vs. Temperature



CST70P03 P-Ch 30V Fast Switching MOSFETs

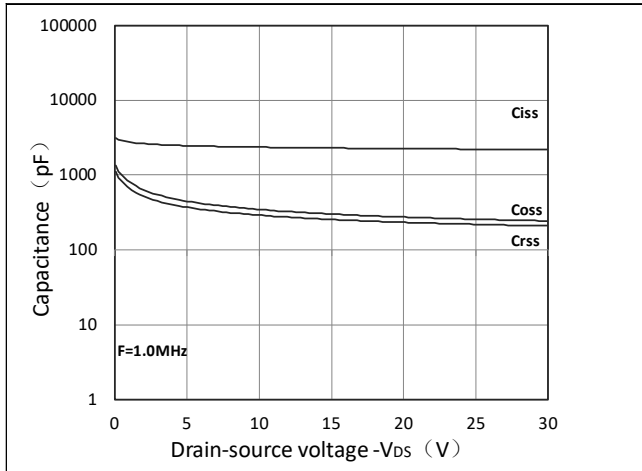

Figure 7. Capacitance Characteristics

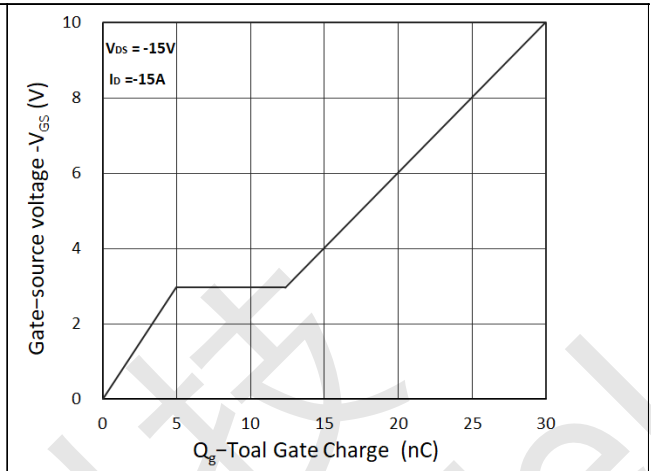

Figure 8. Gate Charge Characteristics

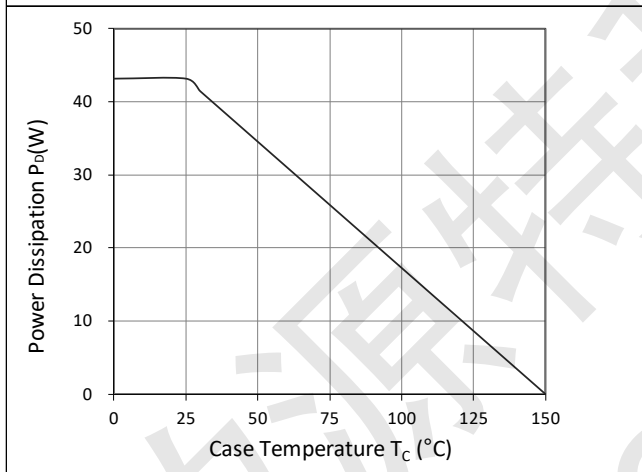

Figure 9. Power Dissipation

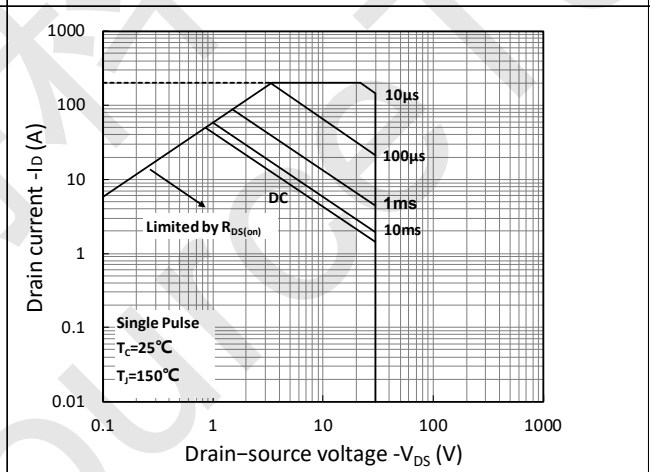

Figure 10. Safe Operating Area

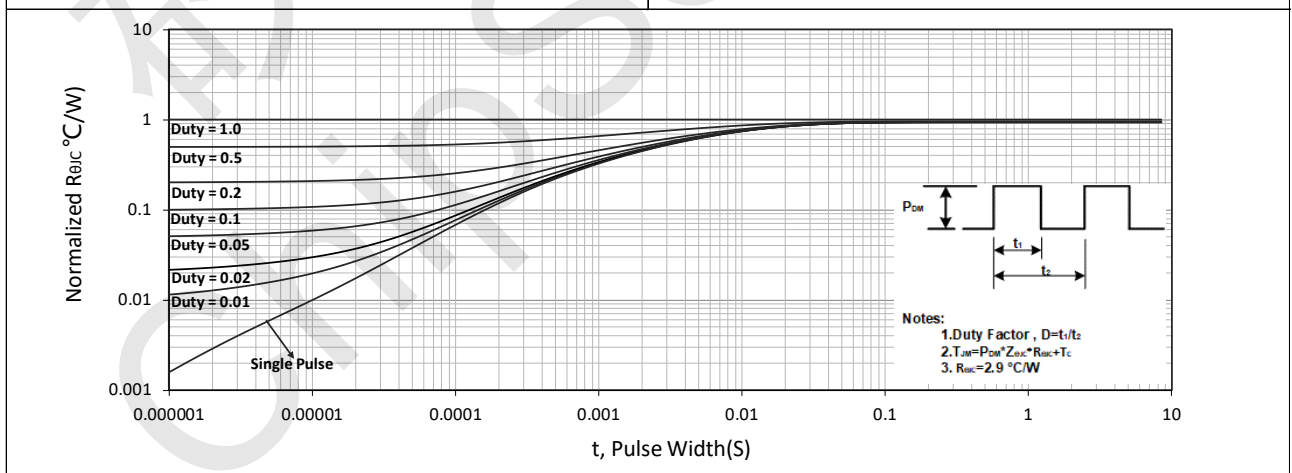
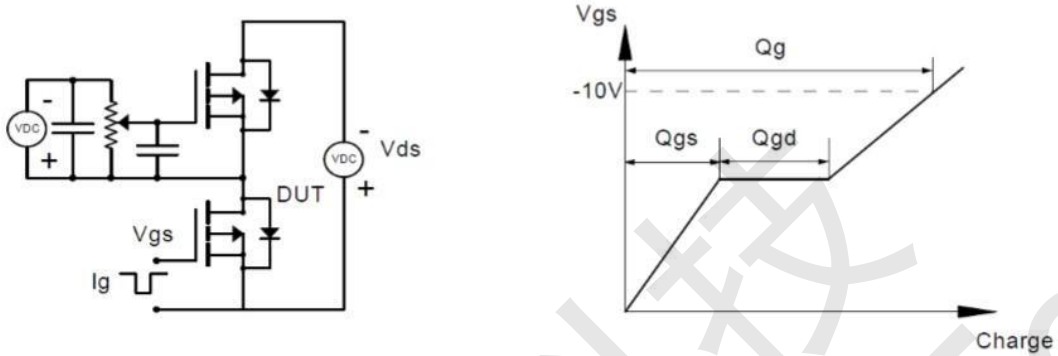

Figure 11. Normalized Maximum Transient Thermal Impedance



CST70P03 Test Circuit

Gate Charge Test Circuit & Waveform



Resistive Switching Test Circuit & Waveforms

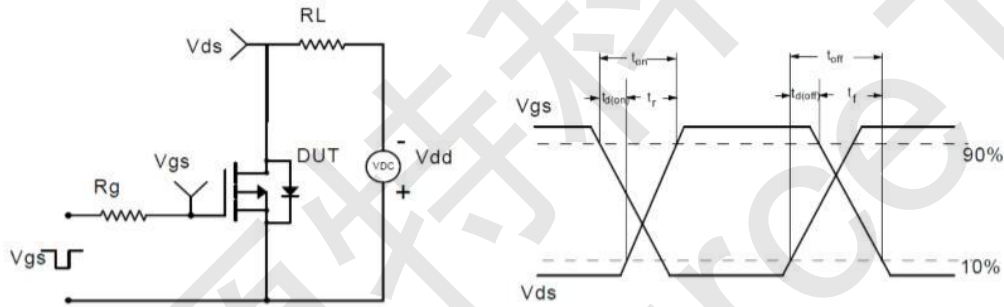

Unclamped Inductive Switching (UIS) Test Circuit & Waveforms

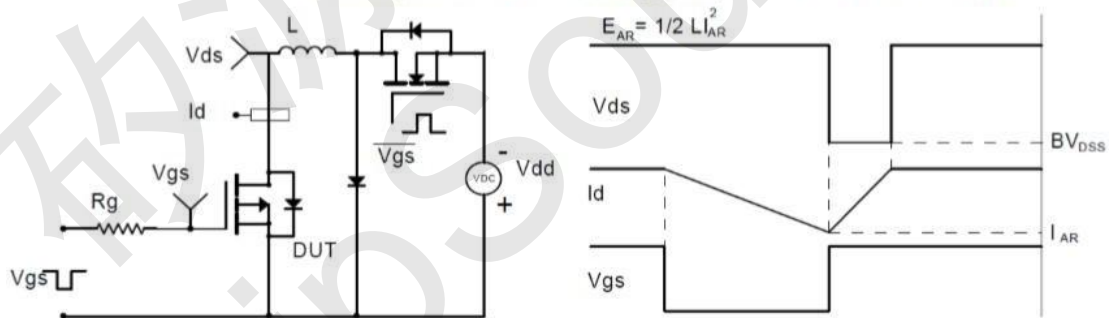

Diode Recovery Test Circuit & Waveforms

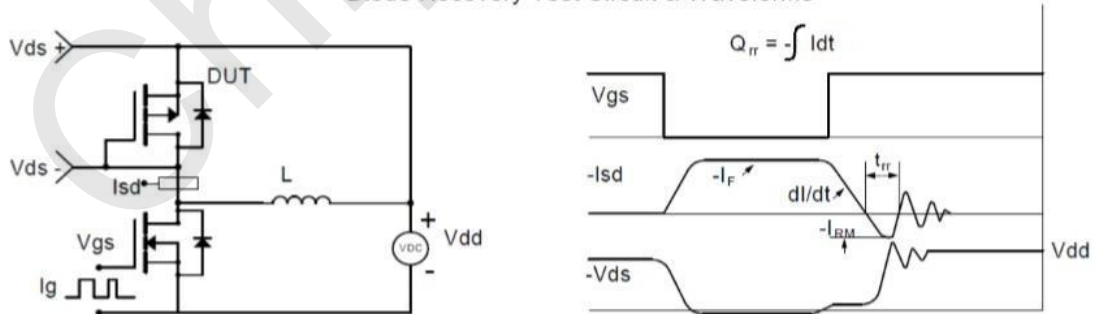



CST70P03 Package Mechanical Data TO-252

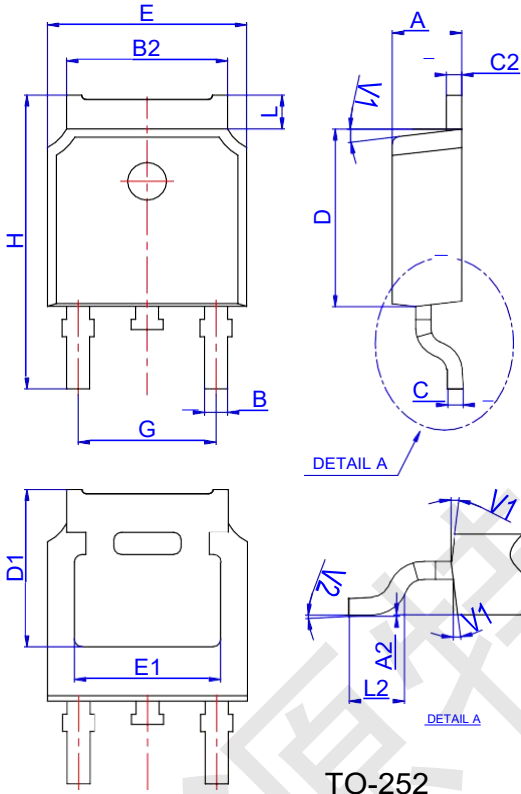

| Ref. | Dimensions | | | | | |
|------|-------------|------|-------|----------|------|-------|
| | Millimeters | | | Inches | | |
| | Min. | Typ. | Max. | Min. | Typ. | Max. |
| A | 2.10 | | 2.50 | 0.083 | | 0.098 |
| A2 | 0 | | 0.10 | 0 | | 0.004 |
| B | 0.66 | | 0.86 | 0.026 | | 0.034 |
| B2 | 5.18 | | 5.48 | 0.202 | | 0.216 |
| C | 0.40 | | 0.60 | 0.016 | | 0.024 |
| C2 | 0.44 | | 0.58 | 0.017 | | 0.023 |
| D | 5.90 | | 6.30 | 0.232 | | 0.248 |
| D1 | 5.30REF | | | 0.209REF | | |
| E | 6.40 | | 6.80 | 0.252 | | 0.268 |
| E1 | 4.63 | | | 0.182 | | |
| G | 4.47 | | 4.67 | 0.176 | | 0.184 |
| H | 9.50 | | 10.70 | 0.374 | | 0.421 |
| L | 1.09 | | 1.21 | 0.043 | | 0.048 |
| L2 | 1.35 | | 1.65 | 0.053 | | 0.065 |
| V1 | | 7° | | | 7° | |
| V2 | 0° | | 6° | 0° | | 6° |

CST70P03 Reel Specification-TO-252-4R

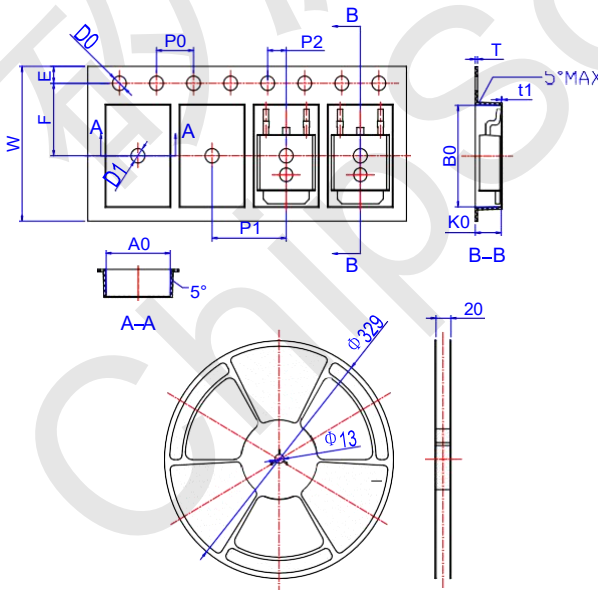

| Ref. | Dimensions | | | | | |
|------|-------------|-------|-------|--------|-------|-------|
| | Millimeters | | | Inches | | |
| | Min. | Typ. | Max. | Min. | Typ. | Max. |
| W | 15.90 | 16.00 | 16.10 | 0.626 | 0.630 | 0.634 |
| E | 1.65 | 1.75 | 1.85 | 0.065 | 0.069 | 0.073 |
| F | 7.40 | 7.50 | 7.60 | 0.291 | 0.295 | 0.299 |
| D0 | 1.40 | 1.50 | 1.60 | 0.055 | 0.059 | 0.063 |
| D1 | 1.40 | 1.50 | 1.60 | 0.055 | 0.059 | 0.063 |
| P0 | 3.90 | 4.00 | 4.10 | 0.154 | 0.157 | 0.161 |
| P1 | 7.90 | 8.00 | 8.10 | 0.311 | 0.315 | 0.319 |
| P2 | 1.90 | 2.00 | 2.10 | 0.075 | 0.079 | 0.083 |
| A0 | 6.85 | 6.90 | 7.00 | 0.270 | 0.271 | 0.276 |
| B0 | 10.45 | 10.50 | 10.60 | 0.411 | 0.413 | 0.417 |
| K0 | 2.68 | 2.78 | 2.88 | 0.105 | 0.109 | 0.113 |
| T | 0.24 | | 0.27 | 0.009 | | 0.011 |
| t1 | 0.10 | | | 0.004 | | |
| 10P0 | 39.80 | 40.00 | 40.20 | 1.567 | 1.575 | 1.583 |