



深圳市矽源特科技有限公司

ShenZhen ChipSourceTek Technology Co. ,Ltd.



矽源特科技
• ChipSourceTek •

CST6118

Single channel DC motor driver chip

User Manual

2022/10

V1.2



CST6118 Introduction:

CST6118 is a single channel brushless DC motor driver chip. The maximum continuous output current can reach 1.8A, and the peak value can reach 2.5A. The chip is equipped with a power MOS full bridge driver, which can drive forward, backward, stop, and brake functions. At the same time, it is equipped with an overtemperature protection circuit to ensure the safety of chip operation.

The full bridge driving architecture and driving method can save peripheral filtering circuits, save costs, and facilitate applications. The extremely small static power consumption of the circuit (less than 1uA) can make the application range of CST6118 more extensive.

CST6118 Advantage:

Adopting a single channel full bridge power drive structure
Working voltage range (1.5V~7V)
Maximum continuous output current can reach 1.8A
Maximum peak output current can reach 2.5A
Including forward/reverse/stop/brake functions
Extremely low quiescent current (typical: 0.1uA)
Low ON resistance (0.4Ω/1000mA)
Built in thermal protection function with hysteresis effect (TSD)
Package: SOP8

CST6118 Application:

DC brush motor drive for toys
Electric toothbrush
Smart lock

CST6118 Order Information:

Part No.	Package	Mark*	Tape/Reel
CST6118	SOP8	CST-LOGO: CST6118 TXXXX	4000/Reel

CST6118 Pin diagram and description:



	Number	Name	input/output	Pin illustrate
	1	NC	--	NC
	2	INA	I	Control signal A input terminal
	3	INB	I	Control signal B input terminal
	4	VDD	I	Power
	5	OUTB	O	Drive B output
	6	NC	--	NC
	7	GND	I	GND
8	OUTA	O	Drive B output	

CST6118 Function Description:

Input Logic Truth Table

INA	INB	OUTA	OUTB	Function
L	L	Hi-Z	Hi-Z	Standby
H	L	H	L	Forward
L	H	L	H	Retreat
H	H	L	L	brake

CST6118 Absolute maximum rating (TA=25°C) :

Parameter	symbol	Value	Unit
Supply voltage	VDDMAX	7.2	V
Maximum output voltage	VOUTMAX	VDD	V
Maximum input voltage	VINMAX	VDD	V
Peak output current	IOUTMAX	2.5	A
Maximum continuous output current	IOUTC	1.8	A
Operating temperature range	Topr	-20~+85	°C
thermal resistance	JA	130	°C/W
Junction temperature	TJ	150	°C
Storage temperature	Tstg	-55~150	°C
Welding temperature		260	°C

Note: 1. During use, exceeding the absolute maximum rated value specified above may cause circuit breakdown, burning, and other issues .

2. The maximum continuous output current depends on the heat dissipation conditions.



CST6118 Recommended operating conditions (TA=25°C) :

Parameter	Symbol	Mini	Typical	Mix	Unit
Supply voltage	VDD	1.6	--	7	V
Input voltage	VIN	0	--	VDD	V
Continuous output current	Iout	--	±1500	--	mA

CST6118 Electrical characteristics (TA=25°C, VDD=5V, RL=15Ω, unless otherwise noted) :

Parameter	Symbol	Test conditions	Mini	Typical	Mix	Unit
VDD standby current	IDDST	INA=INB=L/VDD=5V Output no-load	-	0	10	uA
VDD quiescent current	IVDD	INA=H, INB=L or INA=L, INB=H or INA=H, INB=H VDD=5V Output no-load		106		uA
Input pull-down resistance	RIN			150		KΩ
Input the lowest high-level voltage	VINH		2.0			V
Input the highest low-level voltage	VINL				0.8	V
Output resistance	RON	IO= ±1000mA		0.4		Ω
Input PWM frequency	If		20		40	KHZ
OTP temperature	TSD			165		°C
TSD Hysteresis	TSDH			30		°C

CST6118 Typical waveform:

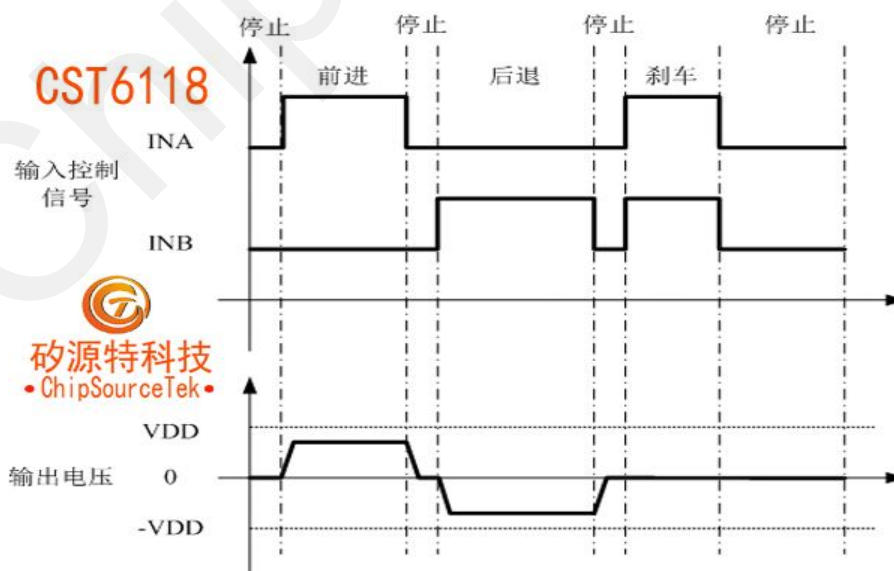



CST6118 Application Description:

1、 Working mode

a) Standby mode

In standby mode, $INA=INB=L$. All internal circuits, including the driving power transistor, are in a closed state. The circuit consumes extremely low current. At this time, both the motor output terminals OUTA and OUTB are in a high resistance state.

b) Forward mode

The definition of forward rotation mode is: $INA=H, INB=L$. At this time, the motor drive end OUTA outputs a high level, and the motor drive end OUTB outputs a low level. The motor drive current flows from OUTA to the motor and from OUTB to the ground. At this time, the rotation of the motor is defined as forward rotation mode.

c) Inversion mode

The definition of reverse mode is: $INA=L, INB=H$. At this time, the motor drive end OUTB outputs a high level, and the motor drive end OUTA outputs a low level. The motor drive current flows from OUTB to the motor and from OUTA to the ground. At this time, the rotation of the motor is defined as reverse mode.

d) Braking mode

The definition of braking mode is: $INA=H, INB=H$. At this time, both the motor drive end OUTA and OUTB output low levels. The energy stored in the motor will be quickly released through the OUTA end NMOS tube or OUTB end NMOS, and the motor will stop rotating in a short period of time. Note that in braking mode, the circuit will consume static power consumption.

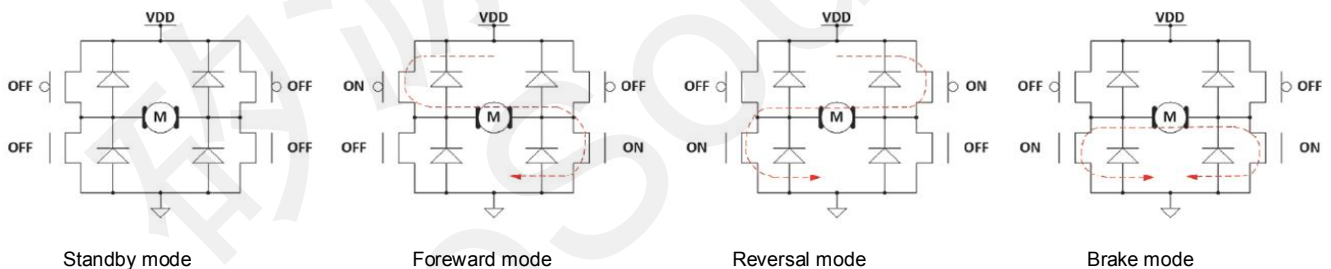

e) PWM mode A

When the input signal INA is a PWM signal, $INB=0$ or $INA=0$, and INB is a PWM signal, the rotational speed of the motor will be controlled by the duty cycle of the PWM signal. In this mode, the motor drive circuit switches between conduction and standby modes. In standby mode, all power transistors are turned off, and the energy stored inside the motor can only be slowly released through the body diode of the power MOSFET.

Note: Due to the presence of high resistance in the working state, the speed of the motor cannot be accurately controlled through the duty cycle of the PWM signal. If the frequency of the PWM signal is too high, the motor will fail to start.

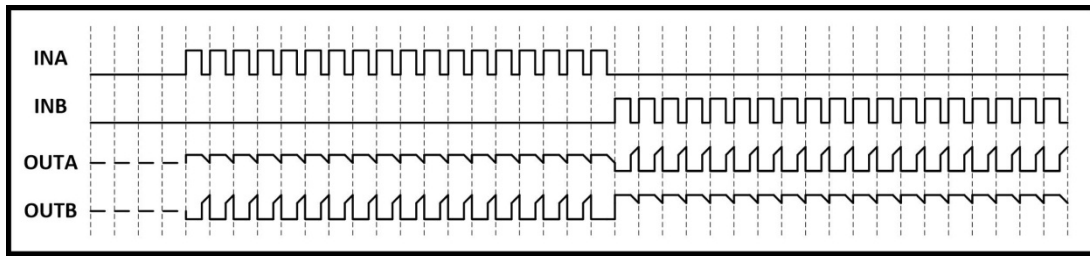

Schematic diagram of PWM mode A signal waveform

f) PWM mode B

When the input signal INA is a PWM signal, $INB=1$ or $INA=1$, and INB is a PWM signal, the rotational speed of the motor will be controlled by the duty cycle of the PWM signal. In this mode, the motor drive circuit outputs between conduction and braking modes, and the energy stored by the motor in braking mode is quickly released through the low side NMOS transistor.

Attention: Due to the presence of a braking state in the working state, the motor energy can be quickly released, and the motor speed can be accurately controlled through the duty cycle of the PWM signal. However, it must be noted that if the PWM signal frequency is too low, it will cause the motor to fail to rotate continuously and smoothly due to entering the braking mode. To reduce motor noise, it is recommended that the PWM signal frequency be greater than 20KHz and less than 40KHz.

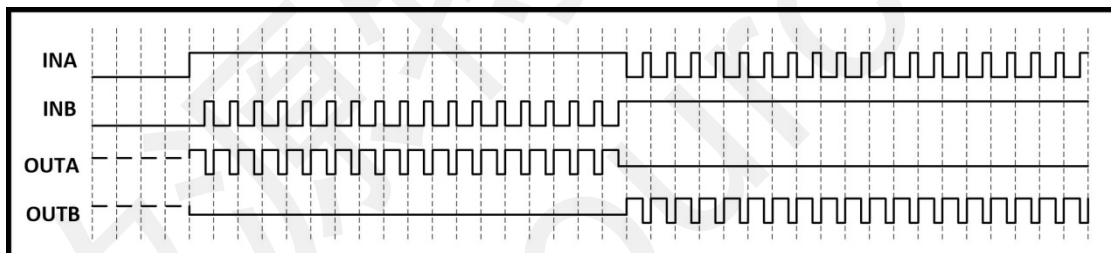

Schematic diagram of PWM mode B signal waveform

CST6118 Typical application circuit diagram:

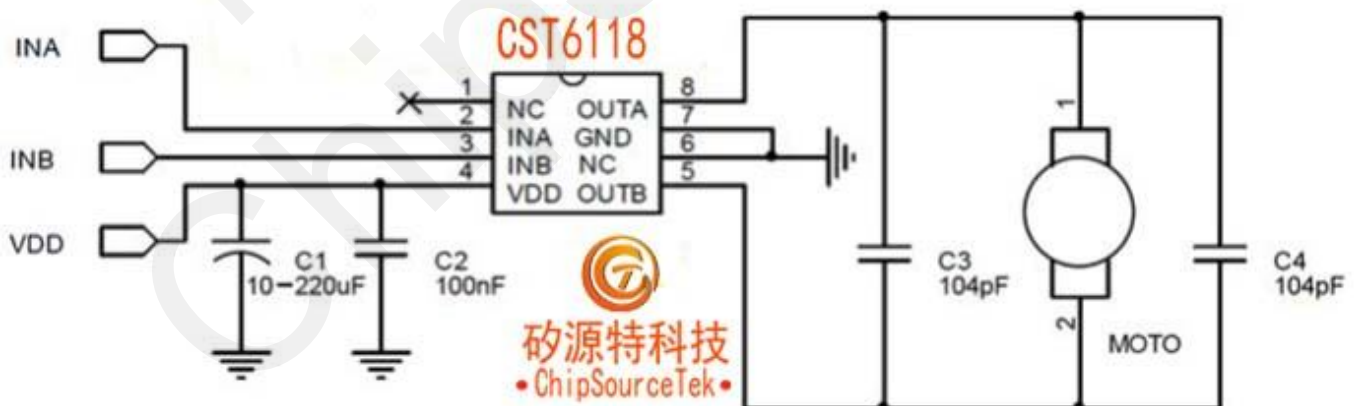

Note: 1. The C4/104P capacitor in the figure is connected in parallel to the motor rather than placed on the PCB. If the motor is not connected in parallel, a position can be reserved on the PCB.

2. Compared to the general application of similar products in the market, C1, C2, and C3 in the figure can be omitted, reducing peripheral devices and saving costs.



CST6118 Special precautions:

In different applications, C1 and C2 can consider welding only one: in 4.5V applications, it is recommended to use one 1uF or more, using a patch capacitor; It is recommended to use a large capacitance of 220uF+100nF chip capacitor in 6V applications; C1 and C2 should be placed close to the VDD pins of the IC, and the connection between the negative electrode of the capacitor and the GND terminal of the IC should also be as short as possible. Although the capacitor is close, the circuit is wound far away. When there is a large capacitor on the PCB board filtering for other chips and it is far from CST6118, it is also necessary to place a small capacitor on the VDD pin of CST6118 according to the above requirements. The C4 (100nF) capacitor in the figure is preferentially connected to the motor. When it is not convenient to solder this capacitor on the motor, C3 should be soldered onto the PCB.

The general low-voltage application of CST6118 can eliminate C1, C2, and C3 capacitors. If the power supply fluctuates significantly or the output driving current is large, it is recommended to add capacitors C2 and C3. Can be selected according to actual situation.

CST6118 is sensitive to static electricity. Anti static measures need to be taken during packaging, transportation, processing, and other processes.

It is recommended not to exceed the peak value of 2.5A of the chip at the moment of motor startup.

The peak current of motor blockage varies depending on the motor. If the peak current of motor blockage is too large, it may burn out the IC.

CST6118 Package information:

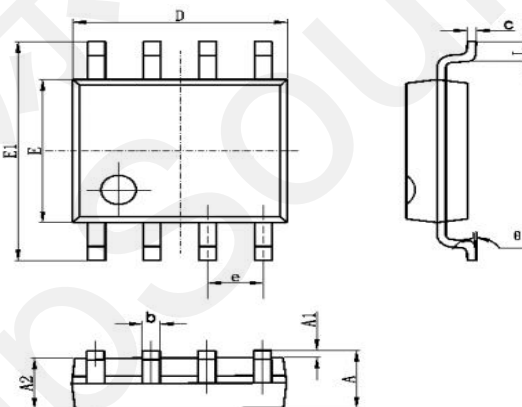

Symbol	Dimensions In Millimeters		Dimensions In Inches	
	Min	Max	Min	Max
A	1.350	1.750	0.053	0.069
A1	0.100	0.250	0.004	0.010
A2	1.350	1.550	0.053	0.061
b	0.330	0.510	0.013	0.020
c	0.170	0.250	0.006	0.010
D	4.700	5.100	0.185	0.200
E	3.800	4.000	0.150	0.157
E1	5.800	6.200	0.228	0.244
e	1.270 (BSC)		0.050 (BSC)	
L	0.400	1.270	0.016	0.050
θ	0°	8°	0°	8°

When the content of this manual is modified or updated, no further notice will be given. Our company reserves

all rights.