



CST5N50 N-Ch 500V Fast Switching MOSFETs

- ★ 100% EAS Guaranteed
- ★ Green Device Available
- ★ Excellent CdV/dt effect decline
- ★ Advanced VD MOSFETS

CST5N50 Product Summary



BVDSS	RDSON	ID
500V	1.45mΩ	5A

CST5N50 Description

The CST5N50 is the Advanced VD N-ch MOSFETS, which provide excellent RDSON and gate charge for most of the synchronous buck converter applications.

The CST5N50 meet the RoHS and Green Product requirement 100% EAS guaranteed with full function reliability approved.

CST5N50 TO252 Pin Configuration

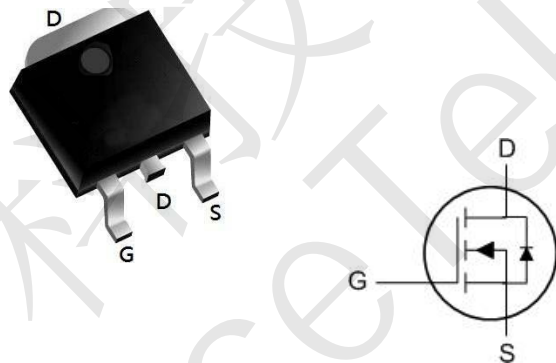

CST5N50 Absolute Maximum Ratings

Symbol	Parameter	Value	Units
V _{DSS}	Drain-Source Voltage	500	V
I _D	Drain Current - Continuous (TC= 25°C) - Continuous (TC= 100°C)	5	A
		2.6*	A
I _{DM}	Drain Current - Pulsed (Note 1)	20*	A
V _{GSS}	Gate-Source Voltage	± 30	V
E _{AS}	Single Pulsed Avalanche Energy (Note 2)	167	mJ
I _{AR}	Avalanche Current (Note 1)	5	A
E _{AR}	Repetitive Avalanche Energy (Note 1)	10.6	mJ
dv/dt	Peak Diode Recovery dv/dt (Note 3)	5	V/ns
P _D	Power Dissipation (TC = 25°C) - Derate above 25°C	24.5	W
		0.2	W/°C
T _j , T _{stg}	Operating and Storage Temperature Range	-55 to +150	°C
T _L	Maximum lead temperature for soldering purposes, 1/8" from case for 5 seconds	300	°C

Thermal Characteristics

Symbol	Parameter	Value	Units
R _{θJC}	Thermal Resistance, Junction-to-Case	4.20	°C/W
R _{θJS}	Thermal Resistance, Case-to-Sink Typ.	--	°C/W
R _{θJA}	Thermal Resistance, Junction-to-Ambient	48.2	°C/W



CST5N50 N-Ch 500V Fast Switching MOSFETs

CST5N50 Electrical Characteristics TC = 25°C unless otherwise noted

Symbol	Parameter	Test Conditions	Min	Typ	Max	Units
BV_{DSS}	Drain-Source Breakdown Voltage	$V_{GS} = 0\text{ V}, I_D = 250\ \mu\text{A}$	500			V
$\Delta BV_{DSS} / \Delta T_J$	Breakdown Voltage Temperature Coefficient	$I_D = 250\ \mu\text{A}$, Referenced to 25°C		0.49		V/°C
I_{DSS}	Zero Gate Voltage Drain Current	$V_{DS} = 500\text{ V}, V_{GS} = 0\text{ V}$			1	μA
		$V_{DS} = 400\text{ V}, TC = 125^\circ\text{C}$			10	μA
I_{GSSF}	Gate-Body Leakage Current, Forward	$V_{GS} = 30\text{ V}, V_{DS} = 0\text{ V}$			100	nA
I_{GSSR}	Gate-Body Leakage Current, Reverse	$V_{GS} = -30\text{ V}, V_{DS} = 0\text{ V}$			-100	nA
On Characteristics						
$V_{GS(TH)}$	Gate Threshold voltage	$V_{DS}=V_{GS}, I_D=250\ \mu\text{A}$	2.0		4.0	V
$R_{DS(On)}$	Drain-Source on-state resistance	$V_{GS}=10\text{ V}, I_D = 2\text{ A}, T_J = 25^\circ\text{C}$		1.45	1.8	Ω
g_{FS}	Forward Transconductance	$V_{DS} = 40\text{ V}, I_D = 2.5\text{ A}$ (Note 4)		2.90		S
Dynamic Characteristics						
C_{iss}	Input capacitance	$V_{DS} = 25\text{ V}, V_{GS} = 0\text{ V}, f = 1.0\text{ MHz}$		415		pF
C_{oss}	Output capacitance			58		pF
C_{riss}	Reverse transfer capacitance			1.4		pF
Switching Characteristics						
$t_{d(on)}$	Turn On Delay Time	$V_{DD} = 250\text{ V}, I_D = 5\text{ A}, R_G = 25\ \Omega$ (Note 4, 5)		7		ns
t_r	Rising Time			22		ns
$t_{d(off)}$	Turn Off Delay Time			15		ns
t_f	Fall Time			23		ns
Q_g	Total Gate Charge	$V_{DS} = 400\text{ V}, I_D = 5\text{ A}, V_{GS} = 10\text{ V}$ (Note 4, 5)		13		nC
Q_{gs}	Gate-Source Charge			4.9		nC
Q_{gd}	Gate-Drain Charge			2.3		nC
Drain-source Diode Characteristics and Maximum Ratings						
I_S	Maximum continuous Drain-source Diode Forward Current				5	A
I_{SM}	Maximum Pulsed Drain-Source Diode Forward Current				20	A
V_{SD}	Diode Forward Voltage	$V_{GS} = 0\text{ V}, I_S = 5\text{ A}$			1.2	V
t_{rr}	Reverse Recovery Time	$V_{GS} = 0\text{ V}, I_S = 5\text{ A}, di_F/dt = 100\text{ A}/\mu\text{s}$		289		ns
Q_{rr}	Reverse Recovery Charge	Note 4)		1.2		μC

Notes:

1. Repetitive Rating : Pulse width limited by maximum junction temperature
2. $L = 10.6\text{ mH}, I_{AS} = 5\text{ A}, V_{DD} = 50\text{ V}, R_G = 25\ \Omega$, Starting $T_J = 25^\circ\text{C}$
3. $I_{SD} \leq 5\text{ A}, di/dt \leq 200\text{ A}/\mu\text{s}, V_{DD} \leq BV_{DSS}$, Starting $T_J = 25^\circ\text{C}$
4. Pulse Test : Pulse width $\leq 300\ \mu\text{s}$, Duty cycle $\leq 2\%$
5. Essentially independent of operating temperature



CST5N50 N-Ch 500V Fast Switching MOSFETs

CST5N50 Typical Characteristics

Table 7 Reverse diode characteristics

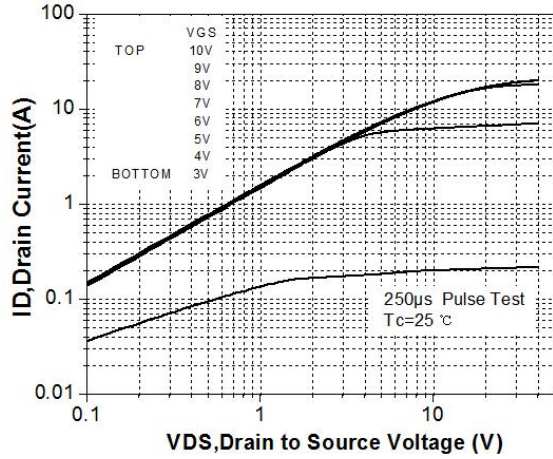

Figure 1. On-Region Characteristics

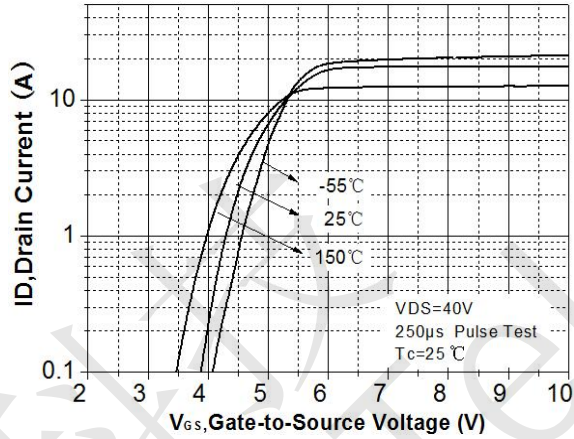

Figure 2. Transfer Characteristics

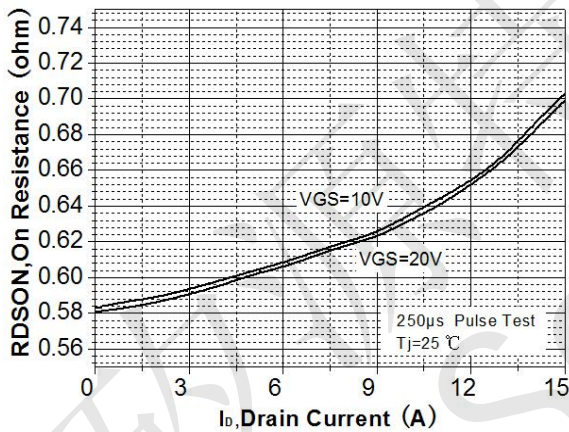

Figure 3. On-Resistance Variation vs Drain Current and Gate Voltage

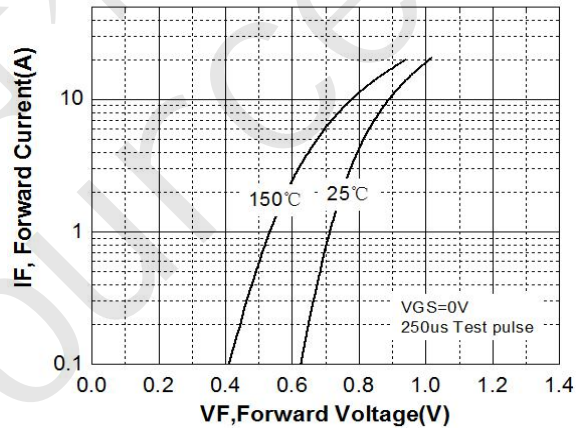

Figure 4. Body Diode Forward Voltage Variation with Source Current and Temperature

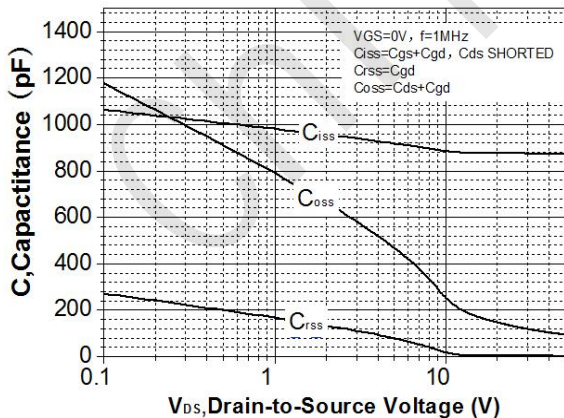

Figure 5. Capacitance Characteristics

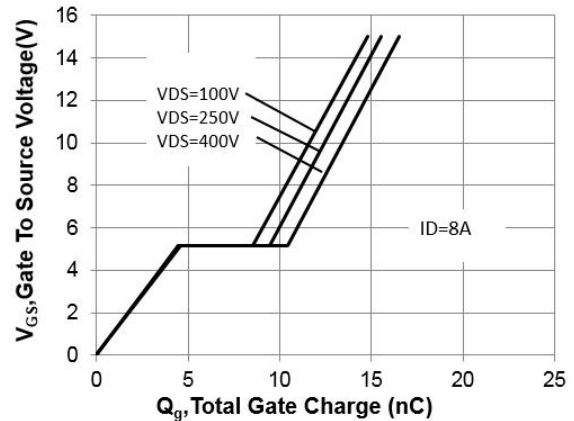

Figure 6. Gate Charge Characteristics



CST5N50 N-Ch 500V Fast Switching MOSFETs

CST5N50 Typical Characteristics (Continued)

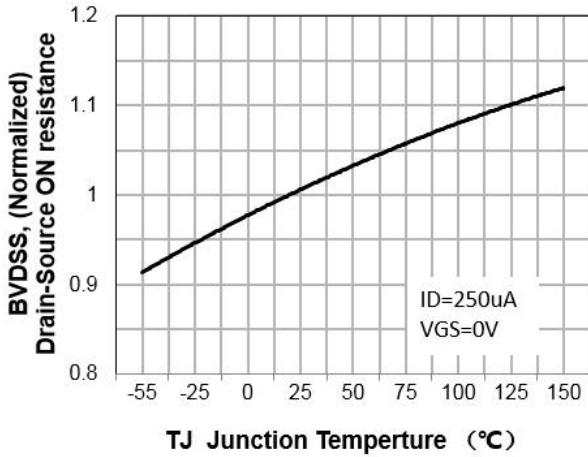

Figure 7. Breakdown Voltage Variation vs Temperature

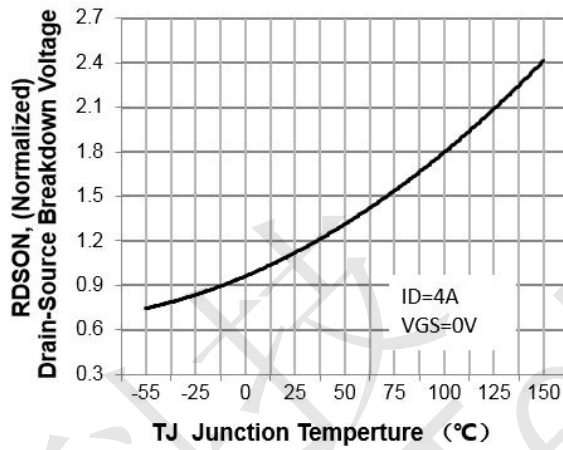

Figure 8. On-Resistance Variation vs Temperature

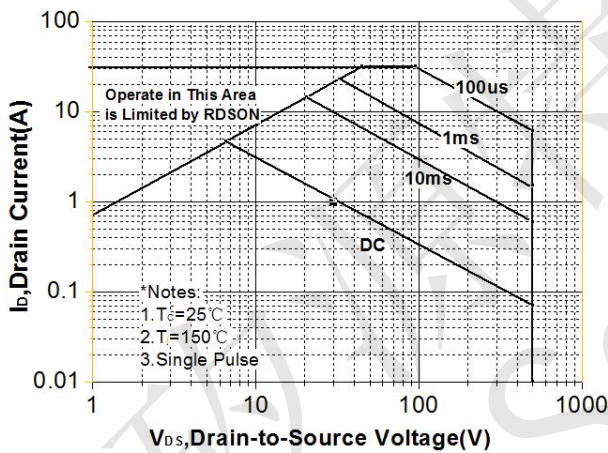

Figure 9. Maximum Safe Operating Area

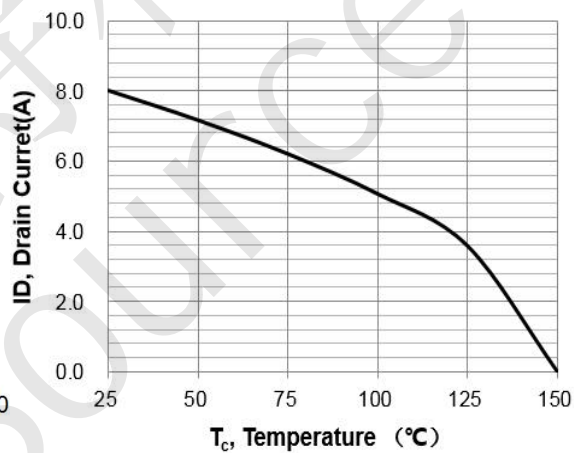

Figure 10. Maximum Drain Current vs Case Temperature

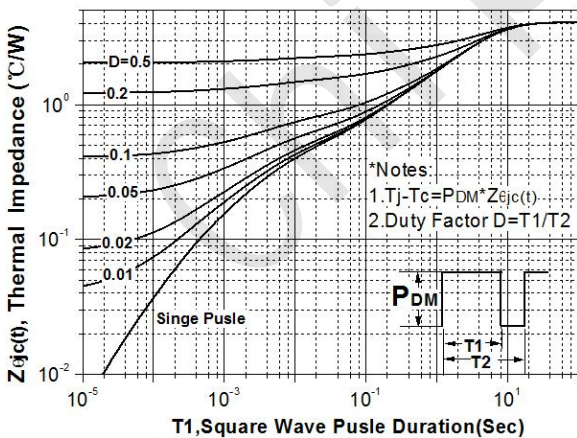
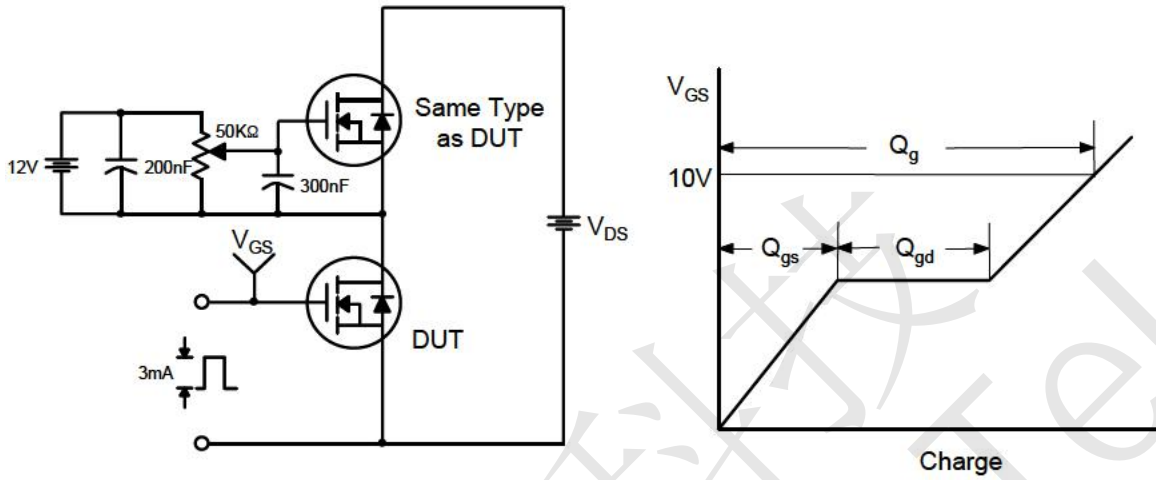

Figure 11. Transient Thermal Response Curve



CST5N50 N-Ch 500V Fast Switching MOSFETs

Gate Charge Test Circuit & Waveform



Resistive Switching Test Circuit & Waveforms

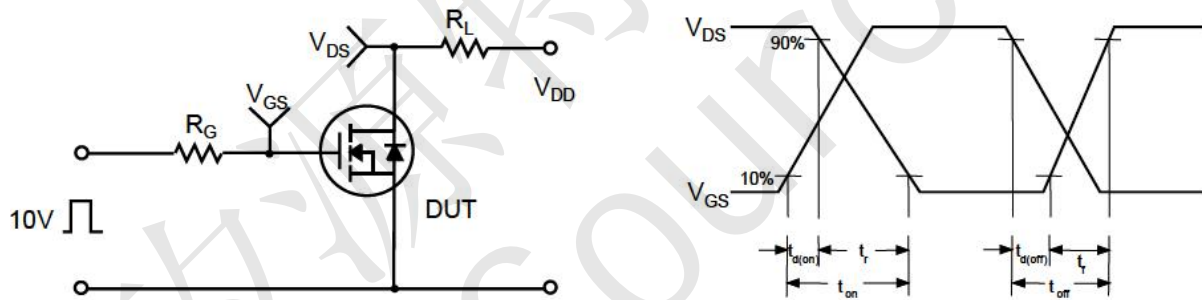

Unclamped Inductive Switching Test Circuit & Waveforms

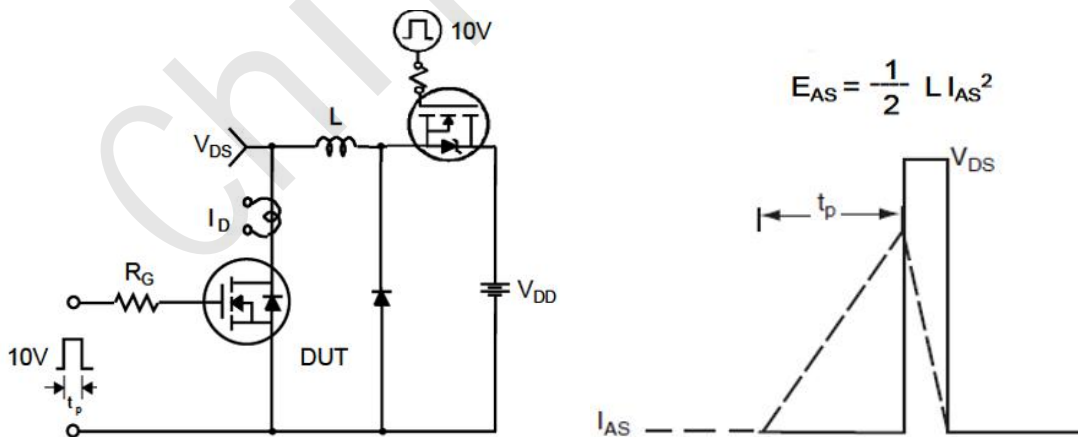



CST5N50 N-Ch 500V Fast Switching MOSFETs

CST5N50 Package Mechanical Data-TO-252

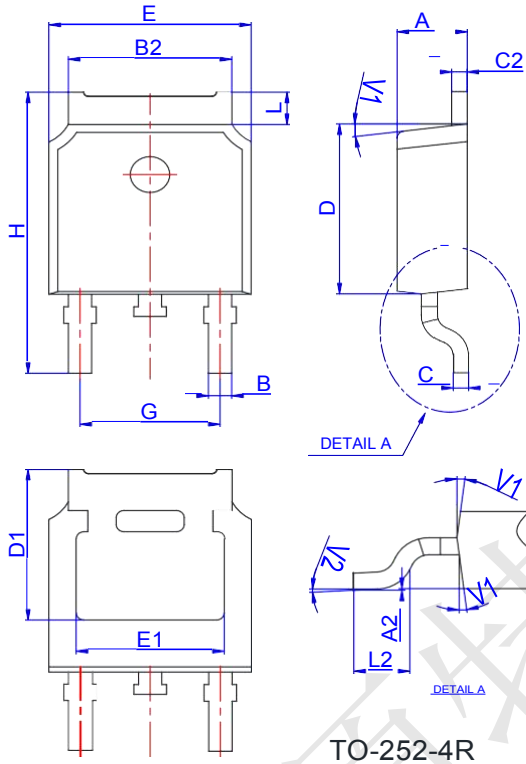

Ref.	Dimensions					
	Millimeters			Inches		
	Min.	Typ.	Max.	Min.	Typ.	Max.
A	2.10		2.50	0.083		0.098
A2	0		0.10	0		0.004
B	0.66		0.86	0.026		0.034
B2	5.18		5.48	0.202		0.216
C	0.40		0.60	0.016		0.024
C2	0.44		0.58	0.017		0.023
D	5.90		6.30	0.232		0.248
D1	5.30REF			0.209REF		
E	6.40		6.80	0.252		0.268
E1	4.63			0.182		
G	4.47		4.67	0.176		0.184
H	9.50		10.70	0.374		0.421
L	1.09		1.21	0.043		0.048
L2	1.35		1.65	0.053		0.065
V1		7°			7°	
V2	0°		6°	0°		6°

CST5N50 Reel Specification-TO-252

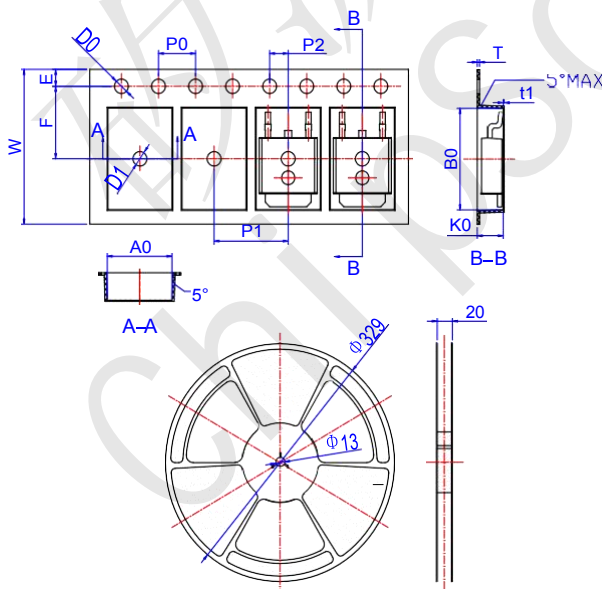

Ref.	Dimensions					
	Millimeters			Inches		
	Min.	Typ.	Max.	Min.	Typ.	Max.
W	15.90	16.00	16.10	0.626	0.630	0.634
E	1.65	1.75	1.85	0.065	0.069	0.073
F	7.40	7.50	7.60	0.291	0.295	0.299
D0	1.40	1.50	1.60	0.055	0.059	0.063
D1	1.40	1.50	1.60	0.055	0.059	0.063
P0	3.90	4.00	4.10	0.154	0.157	0.161
P1	7.90	8.00	8.10	0.311	0.315	0.319
P2	1.90	2.00	2.10	0.075	0.079	0.083
A0	6.85	6.90	7.00	0.270	0.271	0.276
B0	10.45	10.50	10.60	0.411	0.413	0.417
K0	2.68	2.78	2.88	0.105	0.109	0.113
T	0.24		0.27	0.009		0.011
t1	0.10			0.004		
10P0	39.80	40.00	40.20	1.567	1.575	1.583