



CST4882 Dual N-Ch 40V Fast Switching MOSFETs

- ★ Green Device Available
- ★ Super Low Gate Charge
- ★ Excellent CdV/dt effect decline
- ★ Advanced high cell density Trench technology

CST4882 Product Summary



BVDSS	RDSON	ID
40V	17mΩ	8A

CST4882 Description

The CST4882 is the high cell density trenched N-ch MOSFETs, which provide excellent RDSON and gate charge for most of the synchronous buck converter applications.

The CST4882 meet the RoHS and Green Product requirement with full function reliability approved.

CST4882 SOP8 Pin Configuration

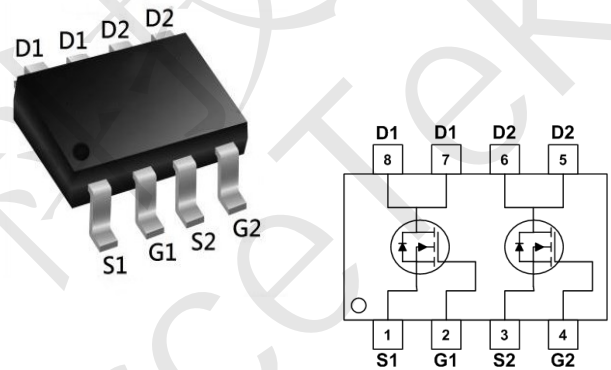

CST4882 Absolute Maximum Ratings (T_A=25°C unless otherwise specified)

Symbol	Parameter	Max.	Units
V _{DSS}	Drain-Source Voltage	40	V
V _{GSS}	Gate-Source Voltage	±20	V
I _D	Continuous Drain Current	T _A = 25°C	8.0
		T _A = 100°C	6
I _{DM}	Pulsed Drain Current ^{note1}	32.8	A
EAS	Single Pulsed Avalanche Energy ^{note2}	13	mJ
P _D	Power Dissipation	T _A = 25°C	2.9
R _{θJA}	Thermal Resistance, Junction to Ambient	63	°C/W
T _J , T _{STG}	Operating and Storage Temperature Range	-55 to +150	°C



CST4882 Dual N-Ch 40V Fast Switching MOSFETs

CST4882 N-Channel Electrical Characteristics ($T_J=25^\circ\text{C}$ unless otherwise specified)

Symbol	Parameter	Test Condition	Min.	Typ.	Max.	Units
Off Characteristic						
$V_{(BR)DSS}$	Drain-Source Breakdown Voltage	$V_{GS}=0V, I_D=250\mu A$	40	-	-	V
I_{DSS}	Zero Gate Voltage Drain Current	$V_{DS}=40V, V_{GS}=0V$	-	-	1.0	μA
I_{GSS}	Gate to Body Leakage Current	$V_{DS}=0V, V_{GS}=\pm 20V$	-	-	± 100	nA
On Characteristics						
$V_{GS(th)}$	Gate Threshold Voltage	$V_{DS}=V_{GS}, I_D=250\mu A$	1.0	1.5	2.5	V
$R_{DS(on)}$	Static Drain-Source on-Resistance <small>note3</small>	$V_{GS}=10V, I_D=8A$	-	17	22	m Ω
		$V_{GS}=4.5V, I_D=5A$	-	25	35	m Ω
Dynamic Characteristics						
C_{iss}	Input Capacitance	$V_{DS}=20V, V_{GS}=0V,$ $f=1.0MHz$	-	633	-	pF
C_{oss}	Output Capacitance		-	67	-	pF
C_{rss}	Reverse Transfer Capacitance		-	58	-	pF
Q_g	Total Gate Charge	$V_{DS}=20V, I_D=8A,$ $V_{GS}=10V$	-	12	-	nC
Q_{gs}	Gate-Source Charge		-	3.2	-	nC
Q_{gd}	Gate-Drain("Miller") Charge		-	3.1	-	nC
Switching Characteristics						
$t_{d(on)}$	Turn-on Delay Time	$V_{DD}=20V, R_L=2.5\Omega$ $V_{GS}=10V, R_{REN}=3\Omega$	-	4	-	ns
t_r	Turn-on Rise Time		-	3	-	ns
$t_{d(off)}$	Turn-off Delay Time		-	15	-	ns
t_f	Turn-off Fall Time		-	2	-	ns
Drain-Source Diode Characteristics and Maximum Ratings						
I_S	Maximum Continuous Drain to Source Diode Forward Current		-	-	8	A
I_{SM}	Maximum Pulsed Drain to Source Diode Forward Current		-	-	32	A
V_{SD}	Drain to Source Diode Forward Voltage	$V_{GS}=0V, I_S=8A$	-	-	1.2	V

Notes:1. Repetitive Rating: Pulse Width Limited by Maximum Junction Temperature

2. EAS condition : $T_J=25^\circ\text{C}, V_{DD}=20V, V_G=10V, L=0.5mH, R_g=25\Omega, I_{AS}=7.2A$

$T_J=25^\circ\text{C}, V_{DD}=-20V, V_G=-10V, L=0.5mH, R_g=25\Omega, I_{AS}=-8.4A$

3. Pulse Test: Pulse Width $\leq 300\mu s$, Duty Cycle $\leq 2\%$



CST4882 Typical Performance Characteristics-N

Figure 1: Output Characteristics

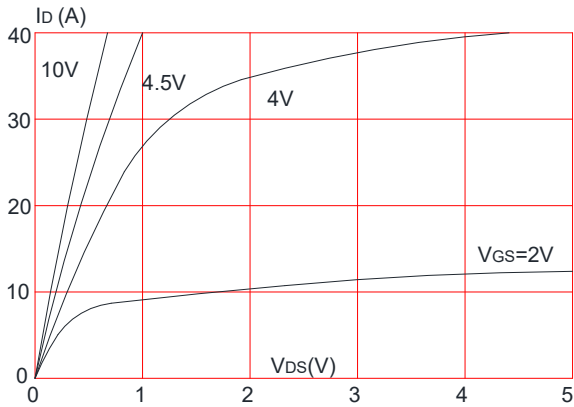

Figure 2: Typical Transfer Characteristics

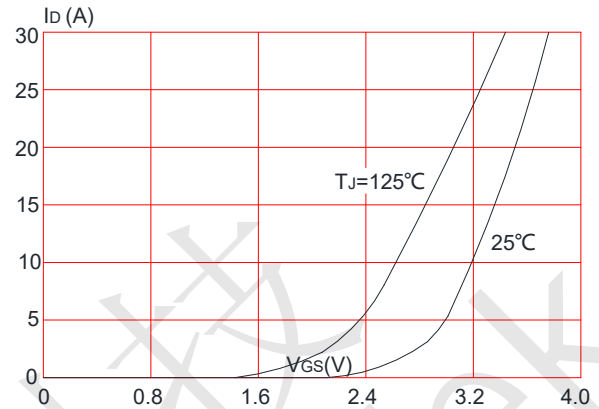

Figure 3: On-resistance vs. Drain Current

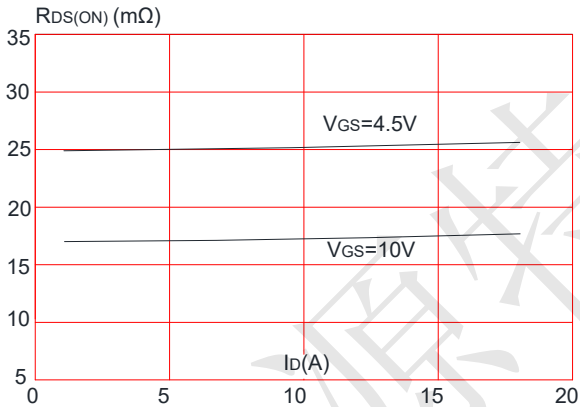

Figure 4: Body Diode Characteristics

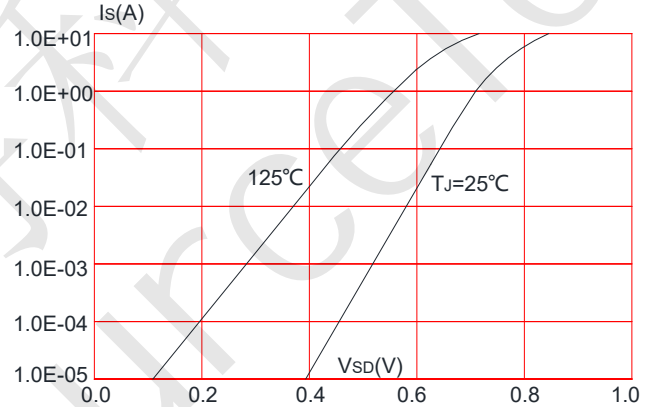

Figure 5: Gate Charge Characteristics

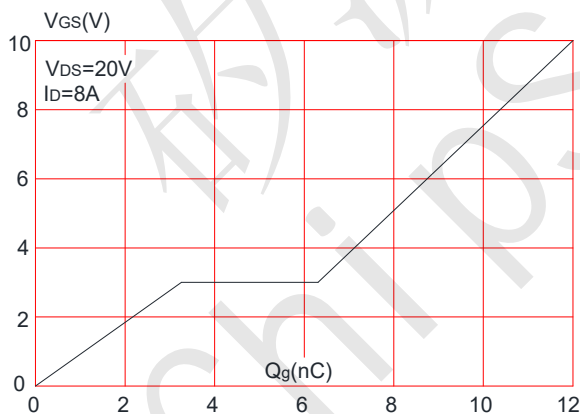
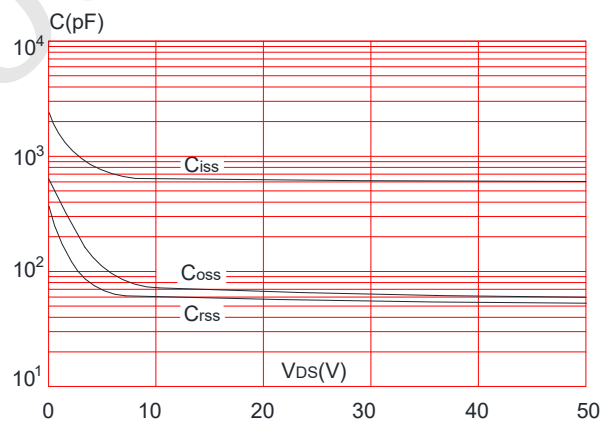

Figure 6: Capacitance Characteristics





CST4882 Dual N-Ch 40V Fast Switching MOSFETs

Figure 7: Normalized Breakdown Voltage vs. Junction Temperature

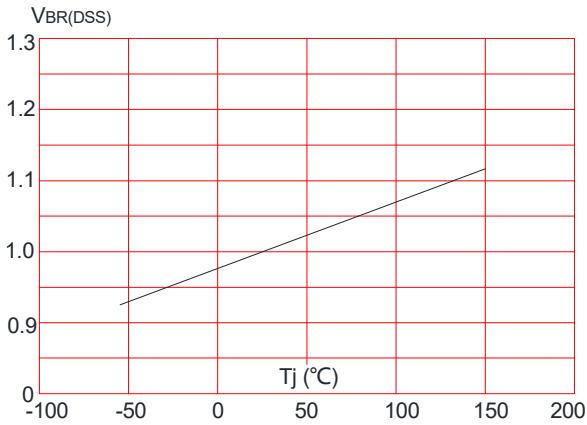

Figure 8: Normalized on Resistance vs. Junction Temperature

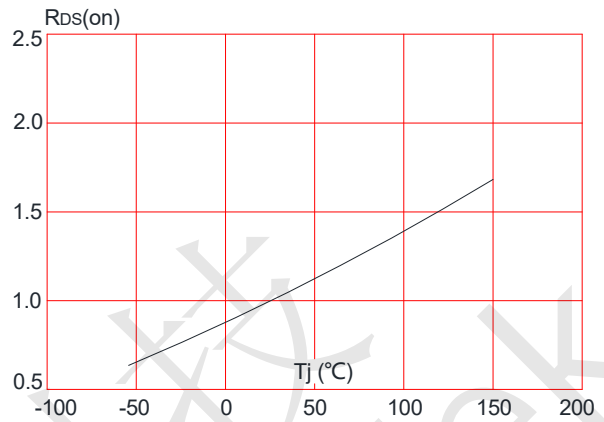

Figure 9: Maximum Safe Operating Area

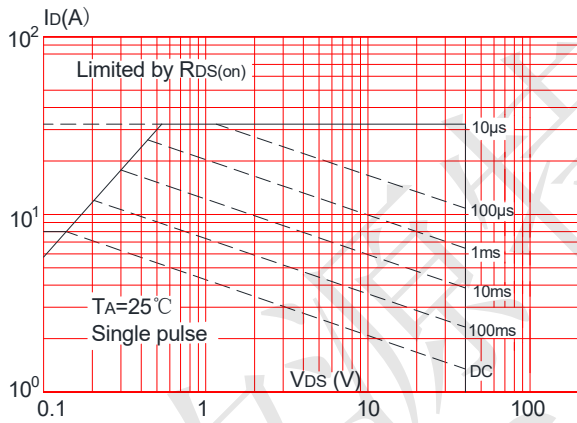

Figure 10: Maximum Continuous Drain Current vs. Ambient Temperature

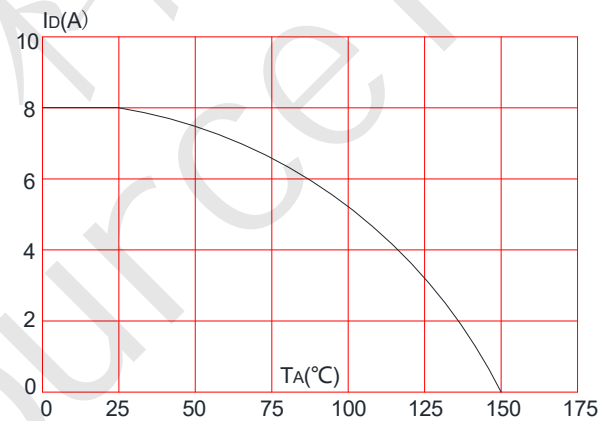
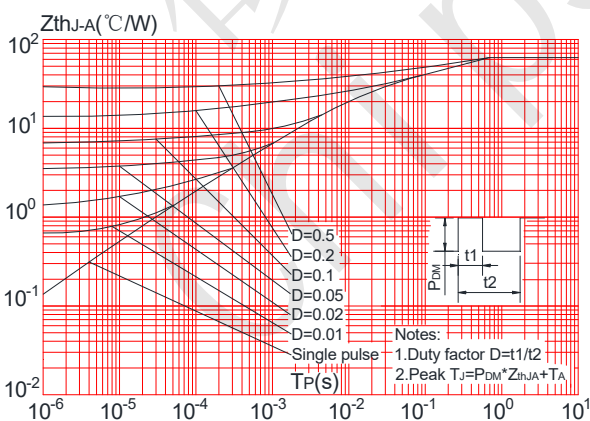
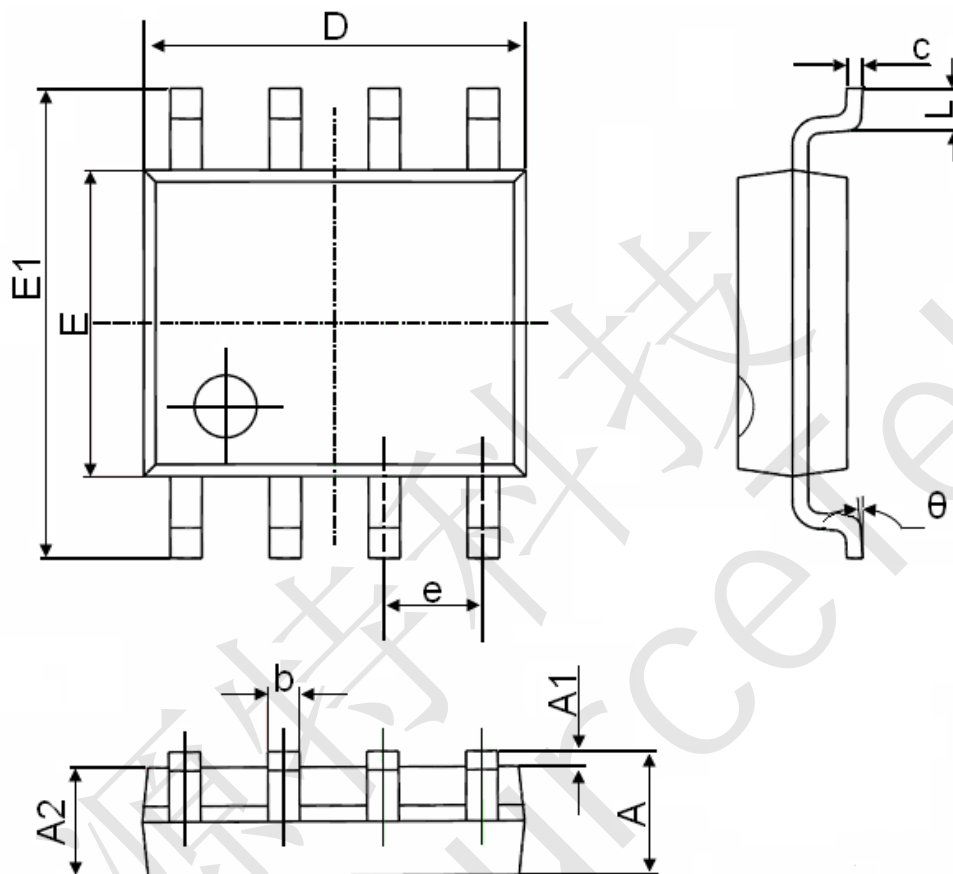

Figure.11: Maximum Effective Transient Thermal Impedance, Junction-to-Ambient





CST4882 SOP-8 Package Information



Symbol	Dimensions In Millimeters		Dimensions In Inches	
	Min.	Max.	Min.	Max.
A	1.350	1.750	0.053	0.069
A1	0.100	0.250	0.004	0.010
A2	1.350	1.550	0.053	0.061
b	0.330	0.510	0.013	0.020
c	0.170	0.250	0.006	0.010
D	4.700	5.100	0.185	0.200
E	3.800	4.000	0.150	0.157
E1	5.800	6.200	0.228	0.244
e	1.270(BSC)		0.050(BSC)	
L	0.400	1.270	0.016	0.050
θ	0°	8°	0°	8°