



### CST3350M Dual N-Ch 20V MOSFETs

- ★ Green Device Available
- ★ Super Low Gate Charge
- ★ Excellent CdV/dt effect decline
- ★ Advanced high cell density Trench technology

#### CST3350M Product Summary



BVDSS	RDS(on)	ID
20V	3.2mΩ	50A

#### CST3350M FEATURE

- TrenchFET Power MOSFET
- Excellent  $R_{DS(on)}$
- Low Gate Charge
- High Power and Current Handling Capability
- Surface Mount Package
- ESD Rating:2000V HBM

#### CST3350M DFN3030-8L Pin Configurations

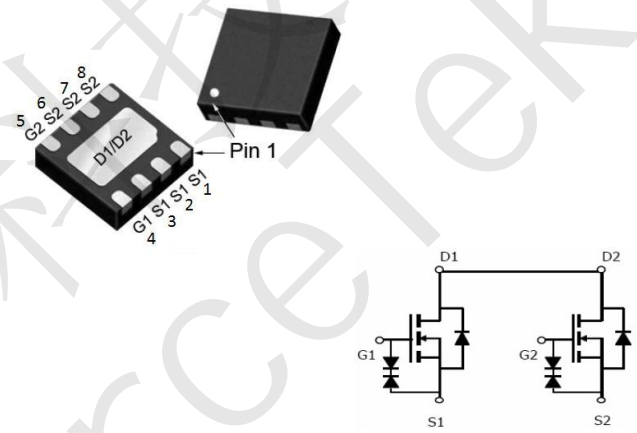

#### CST3350M ABSOLUTE MAXIMUM RATINGS ( $T_a=25^{\circ}\text{C}$ unless otherwise noted)

Parameter	Symbol	Value	Unit
Drain-Source Voltage	$V_{DS}$	20	V
Gate-Source Voltage	$V_{GS}$	$\pm 12$	V
Continuous Drain Current	$I_D$	50	A
Pulsed Drain Current (note 1)	$I_{DM}$	100	A
Thermal Resistance from Junction to Ambient (note 2)	$R_{\theta JA}$	38	$^{\circ}\text{C}/\text{W}$
Junction Temperature	$T_J$	150	$^{\circ}\text{C}$
Storage Temperature	$T_{STG}$	-55~+150	$^{\circ}\text{C}$
Lead Temperature for Soldering Purposes(1/8" from case for 10 s)	$T_L$	260	$^{\circ}\text{C}$



#### CST3350M MOSFET ELECTRICAL CHARACTERISTICS

T<sub>a</sub> =25 °C unless otherwise specified

Parameter	Symbol	Test Condition	Min	Typ	Max	Unit
<b>STATIC CHARACTERISTICS</b>						
Drain-source breakdown voltage	V <sub>(BR)DSS</sub>	V <sub>GS</sub> = 0V, I <sub>D</sub> =250μA	20			V
Zero gate voltage drain current	I <sub>DSS</sub>	V <sub>DS</sub> =19V, V <sub>GS</sub> = 0V			1	μA
Gate-body leakage current	I <sub>GSS</sub>	V <sub>GS</sub> =±12V, V <sub>DS</sub> = 0V			±7	μA
Gate threshold voltage (note 3)	V <sub>GS(th)</sub>	V <sub>DS</sub> =V <sub>GS</sub> , I <sub>D</sub> =250μA	0.5	0.6	1.0	V
Drain-source on-resistance (note 3)	R <sub>DS(on)</sub>	V <sub>GS</sub> =4.5V, I <sub>D</sub> =8.0A		3.2	3.7	mΩ
		V <sub>GS</sub> =2.5V, I <sub>D</sub> =6.0A		4.2	4.8	mΩ
Forward transconductance (note 3)	g <sub>FS</sub>	V <sub>DS</sub> =5V, I <sub>D</sub> =4A		10		S
Diode forward voltage (note 3)	V <sub>SD</sub>	I <sub>S</sub> =1.50A, V <sub>GS</sub> = 0V			1.0	V
<b>DYNAMIC CHARACTERISTICS (note4)</b>						
Input Capacitance	C <sub>iss</sub>	V <sub>DS</sub> =10V, V <sub>GS</sub> =0V, f =1MHz		2610		pF
Output Capacitance	C <sub>oss</sub>			345		pF
Reverse Transfer Capacitance	C <sub>rss</sub>			322		pF
<b>SWITCHING CHARACTERISTICS (note 4)</b>						
Turn-on delay time	t <sub>d(on)</sub>	V <sub>GS</sub> =4.5V, V <sub>DS</sub> =10V, I <sub>D</sub> =6A R <sub>GEN</sub> =3Ω		8.2		ns
Turn-on rise time	t <sub>r</sub>			35		ns
Turn-off delay time	t <sub>d(off)</sub>			372		ns
Turn-off fall time	t <sub>f</sub>			213		ns
Total Gate Charge	Q <sub>g</sub>	V <sub>DS</sub> =10V, V <sub>GS</sub> =4.5V, I <sub>D</sub> =6A		36		nC
Gate-Source Charge	Q <sub>gs</sub>			3.2		nC
Gate-Drain Charge	Q <sub>gd</sub>			13.0		nC

**Notes :**

- 1.Repetitive rating: Pluse width limited by maximum junction temperature
- 2.Surface Mounted on FR4 board, t ≤ 10 sec.
3. Pulse test : Pulse width ≤ 300μs, duty cycle ≤ 2%.
4. Guaranteed by design, not subject to production.



#### CST3350M TYPICAL ELECTRICAL AND THERMAL CHARACTERISTIC

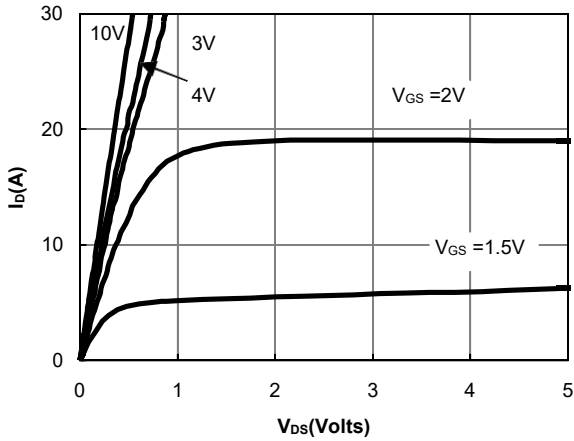

Figure 1: On-Regions Characteristic CS

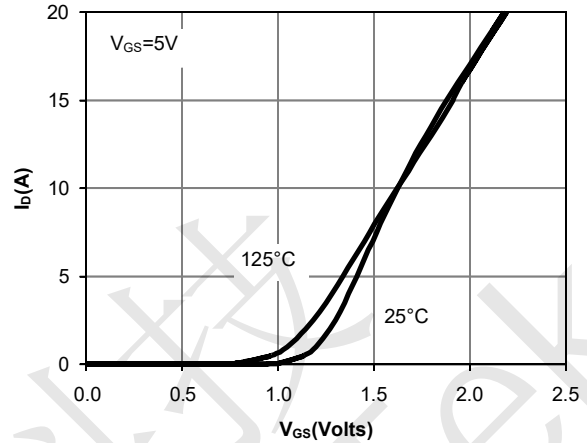

Figure 2: Transfer Characteristics

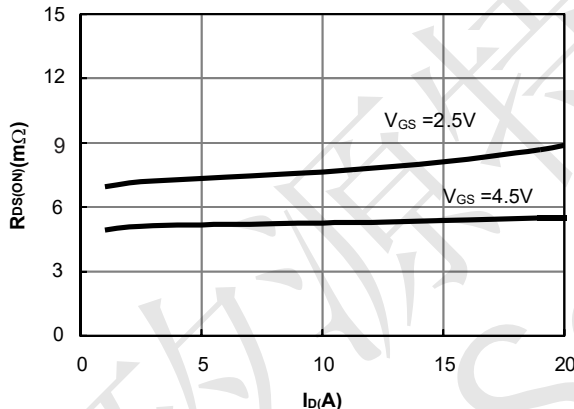

Figure 3: On-Resistance vs. Drain Current and Gate Voltage

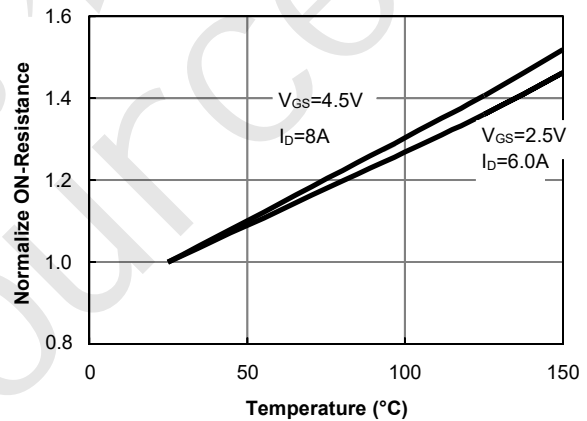

Figure 4: On-Resistance vs. Junction Temperature

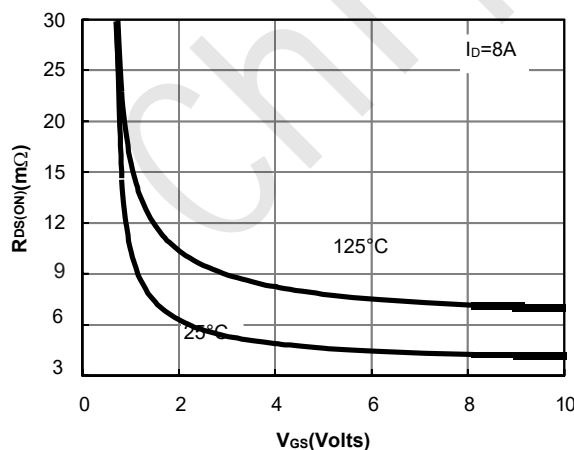

Figure 5: On-Resistance vs. Gate-Source Voltage

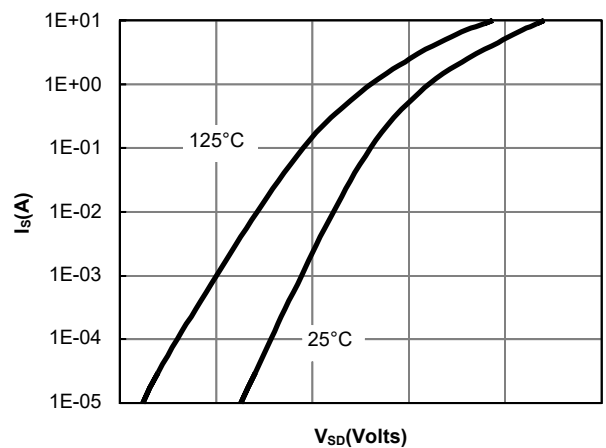

Figure 6: Body-Diode Characteristics



#### CST3350M TYPICAL ELECTRICAL AND THERMAL CHARACTERISTIC

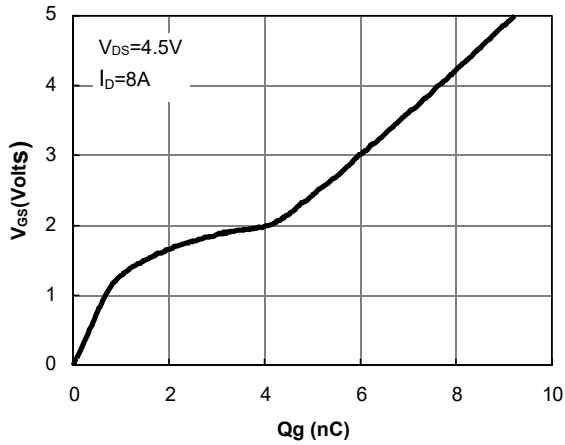

Figure 7: Gate-Charge Characteristics

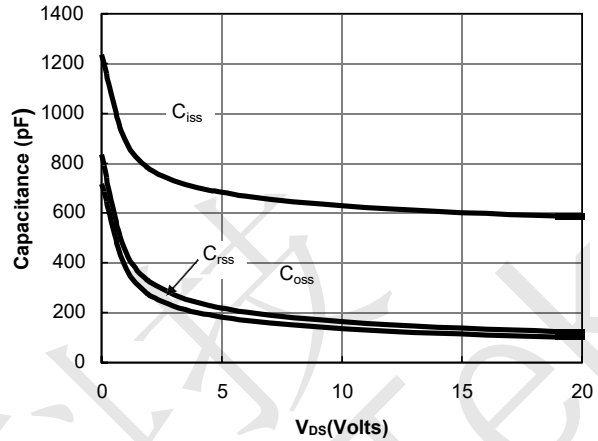

Figure 8: Capacitance Characteristics

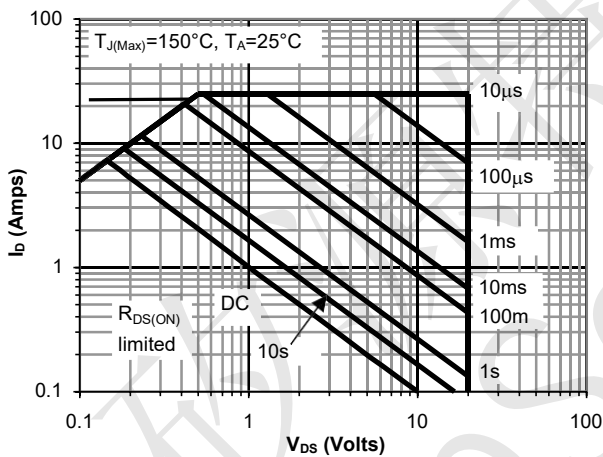

Figure 9: Maximum Forward Biased Safe Operating Area (Note E)

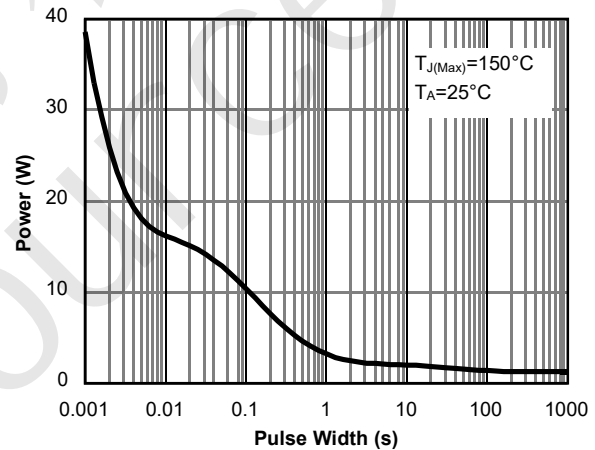

Figure 10: Single Pulse Power Rating Junction-to-Ambient

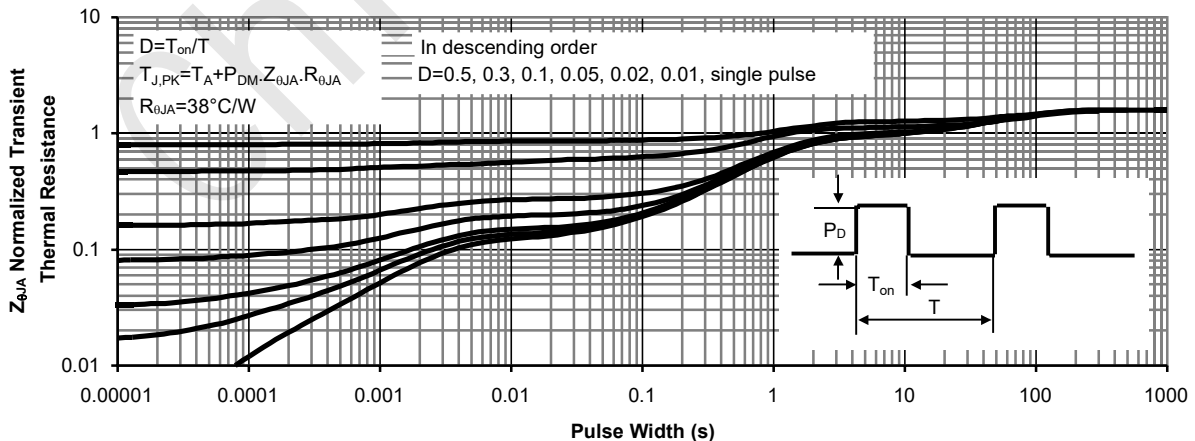
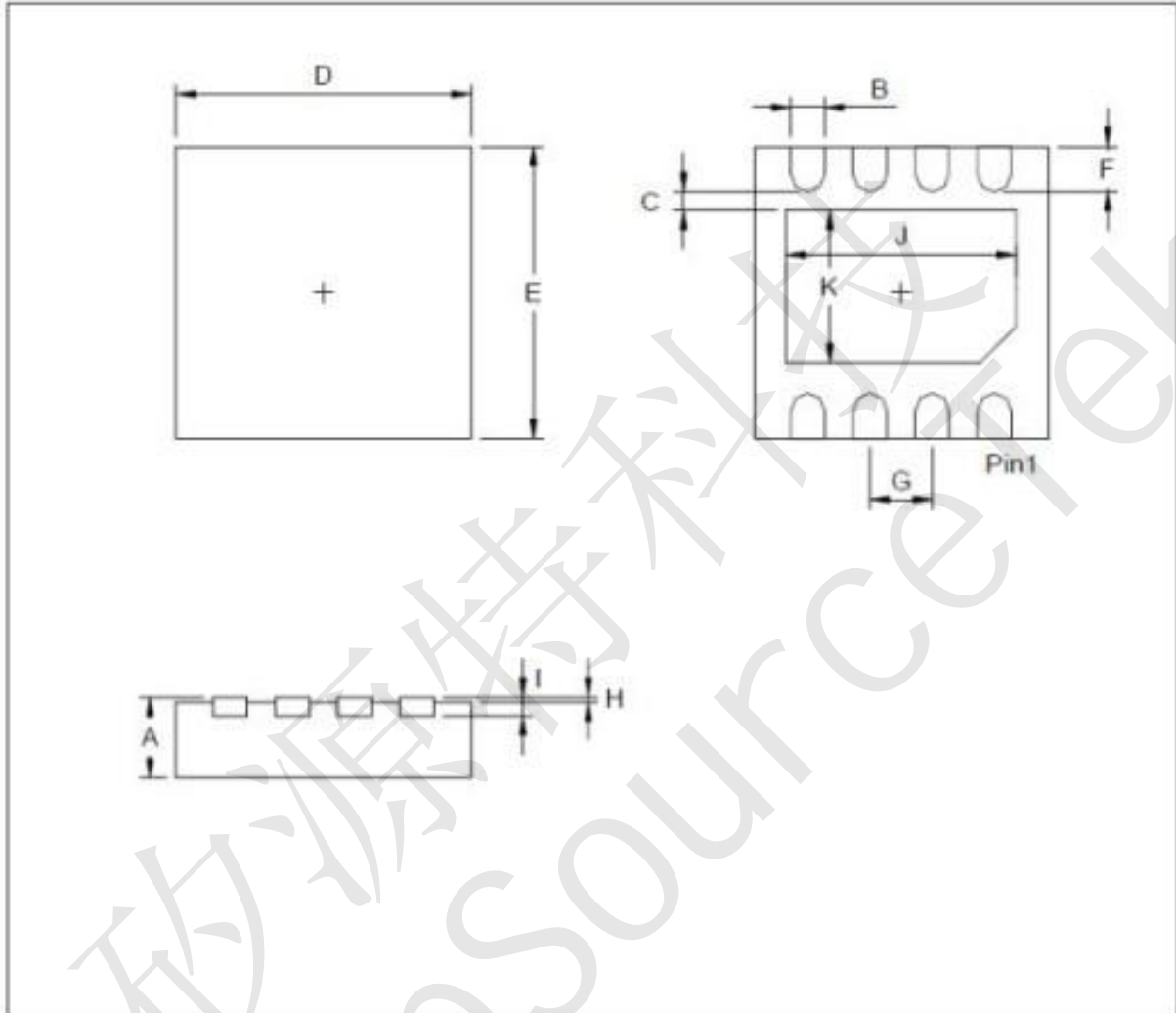

Figure 11: Normalized Maximum Transient Thermal Impedance



CST3350M DFN3030-8L Package Outline Data



Dimension	mm			Dimension	mm		
	Min.	Typ.	Max.		Min.	Typ.	Max.
A	0.7		0.8	I		0.203	
B	0.25		0.35	J	2.2		2.4
C	0.2			K	1.4		1.6
D	2.924		3.076				
E	2.924		3.076				
F	0.324		0.476				
G		0.65					
H	0		0.05				