



CST160N10T N-Ch100V Fast Switching MOSFETs

- ★ Super Low Gate Charge
- ★ 100% EAS Guaranteed
- ★ Green Device Available
- ★ Excellent CdV/dt effect decline
- ★ Advanced high cell density Trench technology

CST160N10T Product Summary



BVDSS	RDSON	ID
100V	3.9 mΩ	160A

CST160N10T Applications

- DC-DC Converters
- Power management functions
- Synchronous-rectification applications

CST160N10T TO-220 Pin Configuration

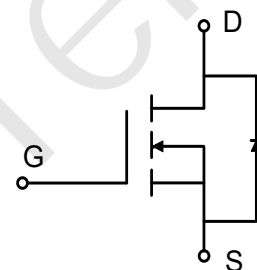
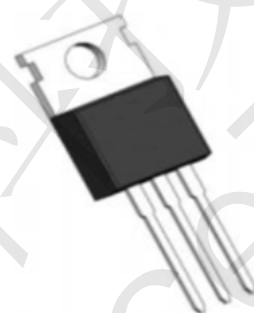

CST160N10T Absolute Maximum Ratings (T_C= 25°C unless otherwise specified) :

Parameter	Symbol	Value	Unit
Drain-Source Voltage	V _{DS}	100	V
Gate-Source Voltage	V _{GS}	±20	V
Continuous Drain Current	I _D	T _C =25°C	160
		T _C =100°C	92
Pulsed Drain Current ¹	I _{DM}	580	A
Single Pulse Avalanche Energy ²	EAS	320	mJ
Total Power Dissipation	P _D	208	W
Operating Junction and Storage Temperature Range	T _J , T _{STG}	-55 to 150	°C

Thermal Characteristics

Parameter	Symbol	Value	Unit
Thermal Resistance from Junction-to-Ambient ³	R _{θJA}	38	°C/W
Thermal Resistance from Junction-to-Case	R _{θJC}	0.6	°C/W



CST160N10T N-Ch100V Fast Switching MOSFETs

CST160N10T Electrical Characteristics (T_J= 25°C, unless otherwise noted)

Parameter	Symbol	Test Conditions	Min.	Typ.	Max.	Unit	
Static Characteristics							
Drain-Source Breakdown Voltage	V _{(BR)DSS}	V _{GS} = 0V, I _D = 250μA	100	-	-	V	
Gate-body Leakage current	I _{GSS}	V _{DS} = 0V, V _{GS} = ±20V	-	-	±100	nA	
Zero Gate Voltage Drain Current	I _{DSS}	V _{DS} = 100V, V _{GS} = 0V	T _J =25°C	-	-	1	μA
			T _J =100°C	-	-	100	
Gate-Threshold Voltage	V _{GS(th)}	V _{DS} = V _{GS} , I _D = 250μA	2	3	4	V	
Drain-Source on-Resistance ⁴	R _{DS(on)}	V _{GS} = 10V, I _D = 20A	-	3.9	4.5	mΩ	
Forward Transconductance ⁴	g _{fs}	V _{DS} =10V, I _D =20A	-	62	-	S	
Dynamic Characteristics⁵							
Input Capacitance	C _{iss}	V _{DS} = 50V, V _{GS} = 0V, f = 1MHz	-	6868	-	pF	
Output Capacitance	C _{oss}		-	740	-		
Reverse Transfer Capacitance	C _{rss}		-	21	-		
Gate Resistance	R _g	f = 1MHz	-	1.3	-	Ω	
Switching Characteristics⁵							
Total Gate Charge	Q _g	V _{GS} = 10V, V _{DS} = 50V, I _D =20A	-	112.5	-	nC	
Gate-Source Charge	Q _{gs}		-	30.5	-		
Gate-Drain Charge	Q _{gd}		-	27.3	-		
Turn-on Delay Time	t _{d(on)}	V _{GS} = 10V, V _{DD} = 50V, R _G = 3Ω, I _D = 20A	-	33	-	ns	
Rise Time	t _r		-	39	-		
Turn-off Delay Time	t _{d(off)}		-	67.1	-		
Fall Time	t _f		-	32	-		
Body Diode Reverse Recovery Time	t _{rr}	I _F = 20A, dI/dt=100A/μs	-	58.7	-	ns	
Body Diode Reverse Recovery Charge	Q _{rr}		-	97.3	-	nC	
Drain-Source Body Diode Characteristics							
Diode Forward Voltage ⁴	V _{SD}	I _D = 20A, V _{GS} = 0V	-	-	1.2	V	
Continuous Source Current	I _S	T _C =25°C	-	-	160	A	

Notes:

1. Repetitive rating, pulse width limited by junction temperature T_{J(MAX)}=150°C.
2. The EAS data shows Max. rating . The test condition is V_{DD}=35V, V_{GS}=10V, L=0.4mH, I_{AS}=40A.
3. The data tested by surface mounted on a 1 inch² FR-4 board with 2OZ copper, The value in any given application depends on the user's specific board design.
4. The data tested by pulsed , pulse width ≤ 300us , duty cycle ≤ 2%.
5. This value is guaranteed by design hence it is not included in the production test.



CST160N10T N-Ch100V Fast Switching MOSFETs

CST160N10T Typical Characteristics

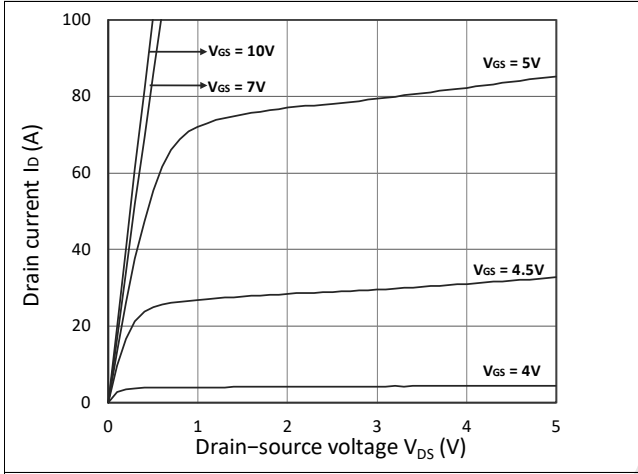

Figure 1. Output Characteristics

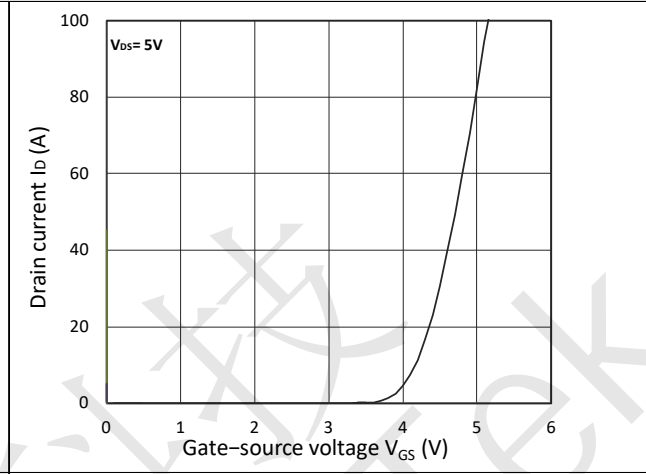

Figure 2. Transfer Characteristics

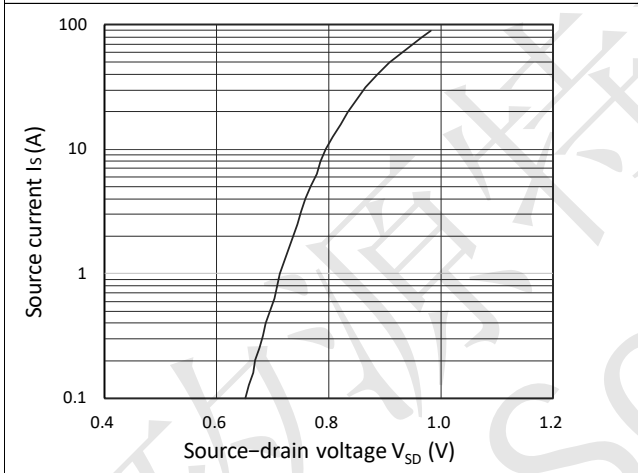

Figure 3. Forward Characteristics of Reverse

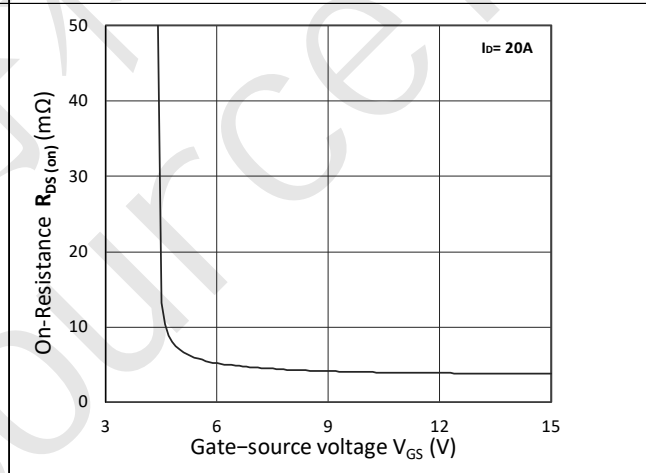

Figure 4. $R_{DS(ON)}$ vs. V_{GS}

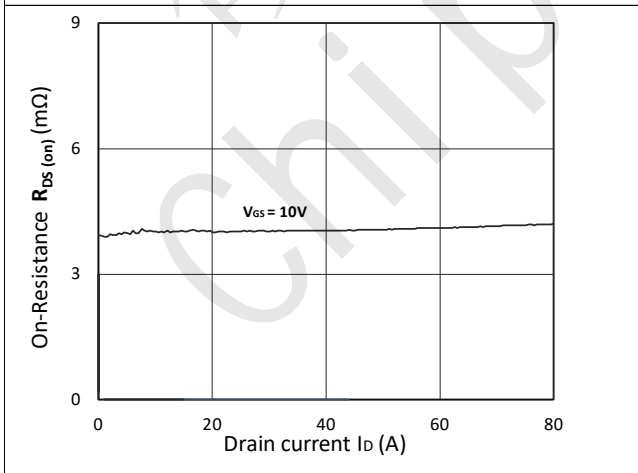

Figure 5. $R_{DS(ON)}$ vs. I_D

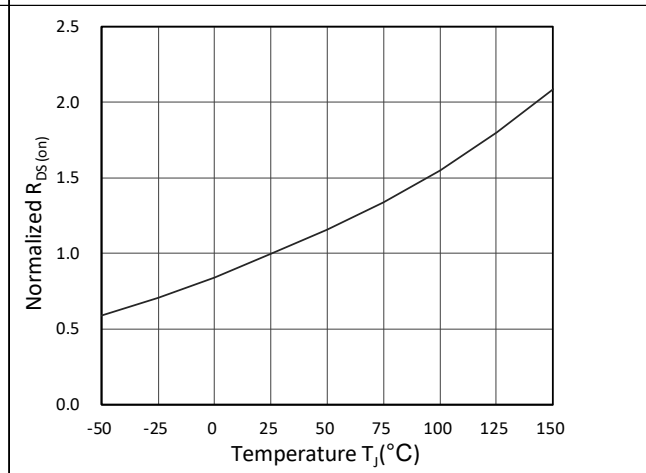

Figure 6. Normalized $R_{DS(ON)}$ vs. Temperature



CST160N10T N-Ch100V Fast Switching MOSFETs

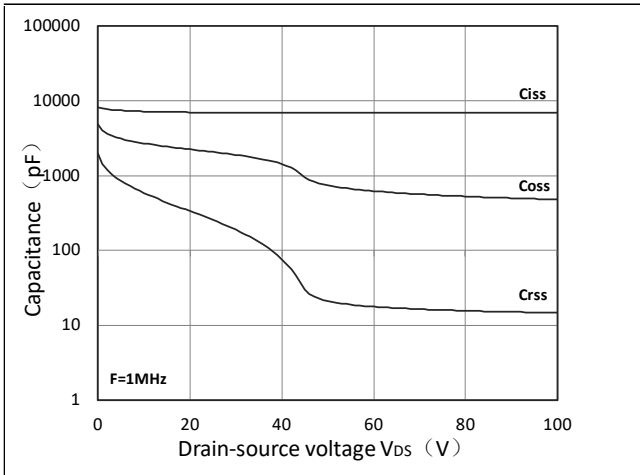

Figure 7. Capacitance Characteristics

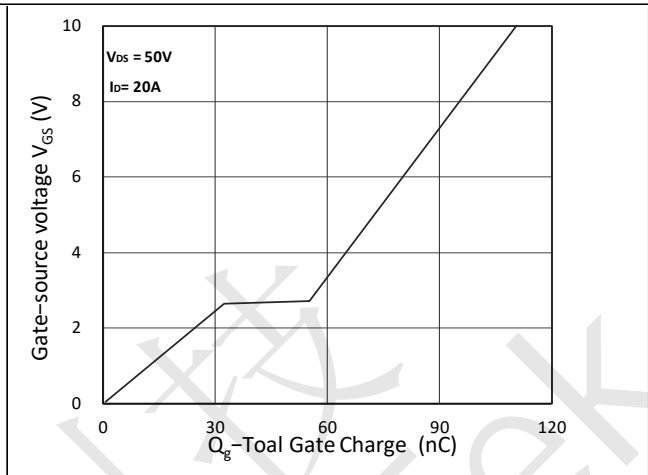

Figure 8. Gate Charge Characteristics

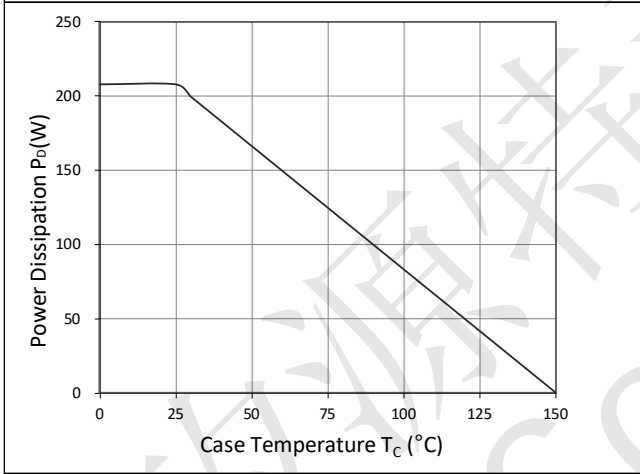

Figure 9. Power Dissipation

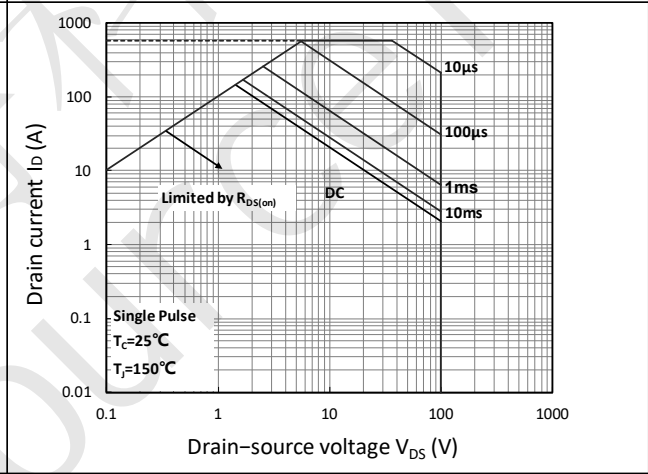

Figure 10. Safe Operating Area

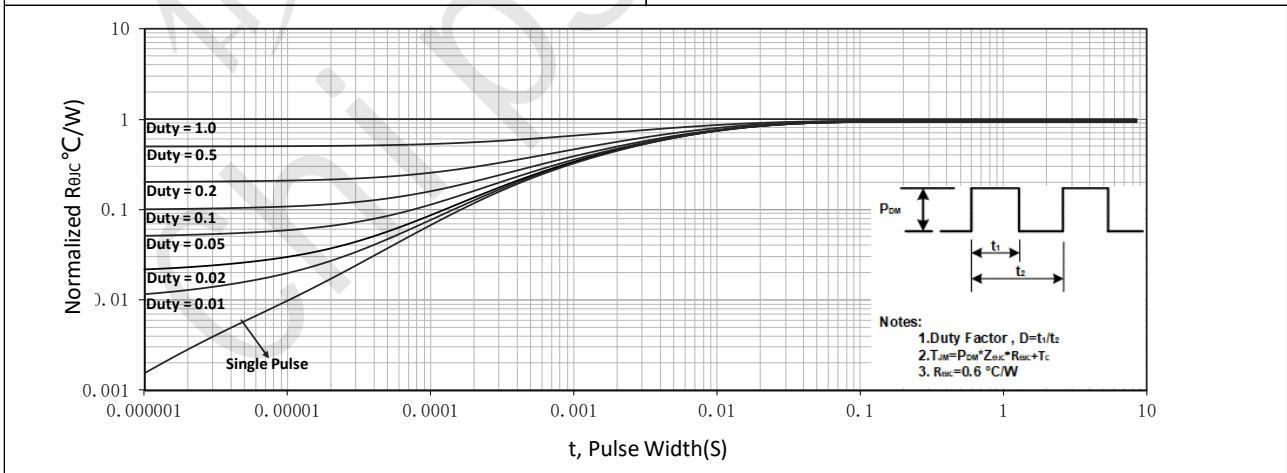

Figure 11. Normalized Maximum Transient Thermal Impedance



CST160N10T N-Ch100V Fast Switching MOSFETs

CST160N10T Test Circuit

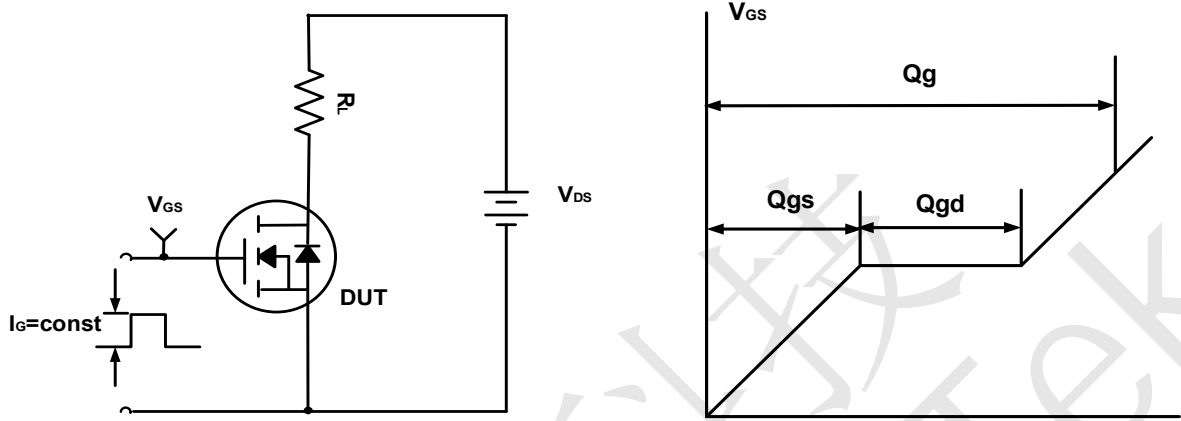

Figure A. Gate Charge Test Circuit & Waveforms

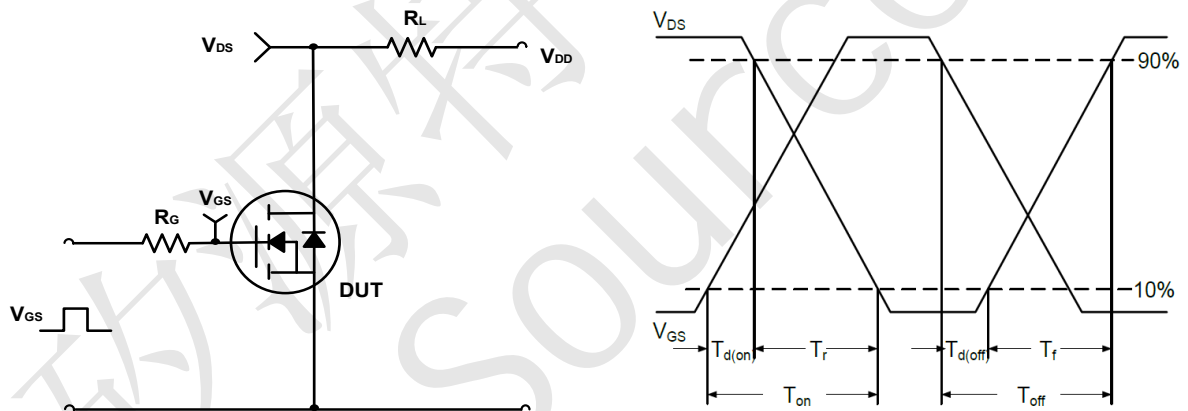

Figure B. Switching Test Circuit & Waveforms

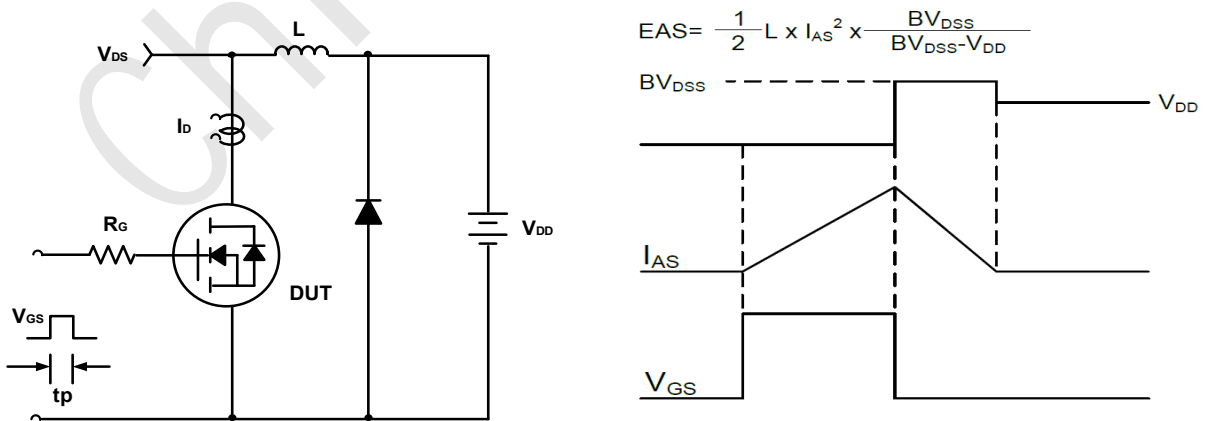

Figure C. Unclamped Inductive Switching Circuit & Waveforms



CST160N10T N-Ch100V Fast Switching MOSFETs

CST160N10T Mechanical Dimensions for TO-220

COMMON DIMENSIONS

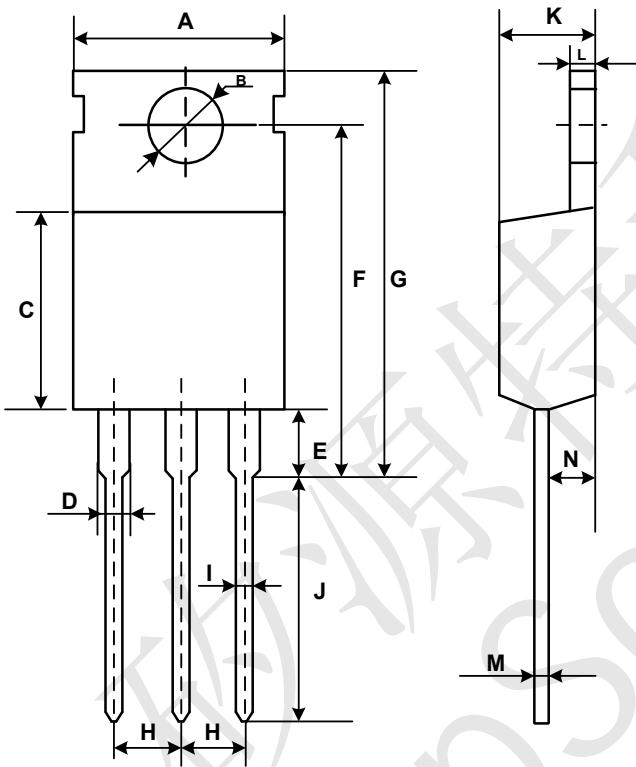

SYMBOL	MM	
	MIN	MAX
A	9.70	10.30
B	3.40	3.80
C	8.80	9.40
D	1.17	1.47
E	2.60	3.50
F	15.10	16.70
G	19.55MAX	
H	2.54REF	
I	0.70	0.95
J	9.35	11.00
K	4.30	4.77
L	1.20	1.45
M	0.40	0.65
N	2.20	2.60