



深圳市矽源特科技有限公司
ShenZhen ChipSoureTek Technology Co.,Ltd.

CST1602B

Data Sheet

V1.0

128K Embedded Flash

Hi-Performance 16-bit Speech Processor



1. General Description	2
2. Features.....	3
3. Application Field.....	4
4. Block Diagram.....	4
4.1 Pin Assignments /Description.....	5
5. Function Descriptions.....	6
5.1 TxP16S2	6
5.2 TxP16S2 Registers	6
5.2.1 Special Registers.....	7
5.2.2 Common I/O Registers	8
5.2.3 Basic System Registers	9
5.3 PC Stack	12
5.4 Interrupt	12
5.4.1 Interrupt Vector Table.....	12
5.4.2 Interrupt Controller.....	13
5.4.3 Interrupt Processing.....	14
5.5 MAC (16-bit X 16-bit Multiplier and Accumulator)	15
6. Memory Configuration.....	17
6.1 Internal Program/Parameter Memory.....	17
6.2 Internal Data Working SRAM.....	17
6.3 Data Stack.....	18
7. Peripherals.....	19
7.1 Programmable Timers.....	19
7.1.1 Audio PWM Timer	19
7.1.2 Timer1 & Timer2	19
7.1.3 RTC(Real Time Clock) Timer	20
7.2 General Purpose I/O Ports.....	21
7.3 Extension Device	23
7.3.1 SPI Master Controller	23
7.3.2 PortA3 for IR 38KHz Modulation.....	25
7.3.3 Touch Controller.....	26
7.4 Audio Output	28
7.4.1 Mono 16-bit PWM Output	28
7.5 Auto-FIFO	29
8. Flash Control.....	30
8.1 Flash Structure.....	30
8.2 Flash Sector Erase	30
8.3 Flash Word Programming	30



8.4 Flash Word Read	31
8.5 Flash unlock/lock for Programming/Erase instruction	31
9. Others	32
9.1 Dynamic System Clock	32
9.2 Low Voltage Detector	33
10. System Control	34
10.1 Halt Mode & Wake up	34
10.2 Watch Dog Timer Reset (WDT)	34
10.3 Low Voltage Reset	34
10.4 Reset System.....	34
10.5 Clock System Architecture	35
10.6 Ultra Deep Sleep.....	36
10.6.1 Control Registers	36
10.6.2 Flow Chart	37
10.6.3 Example Code	38
11. Electrical Characteristics	41
11.1 Absolute Maximum Rating.....	41
11.2 DC/AC Characteristics	41
12. Application Circuit and Chip Power Circuit.....	42
13. Appendix:	43
14. Package: SOP8 / SOP16 / SSOP24 / SOP16-2	45
15. SPI Operation Sequence	49
16. Revision history	51



CST1602B 16-bit Speech Processor

1. CST1602B General Description

The TxP16S2™ is a high performance 16-bit MCU, running up to 13MHz and provided with 128K FLASH and total 3K SRAM for high performance process of audio algorithm. It is the new generation computational kernel for Flash Speech series. It has initially aimed at the areas of speech application to demonstrate its profession. TxP16S2 furnish with a fast unit, which allows calculation instructions to be issued with access memory simultaneously during one cycle. The CST1602B is equipped with TxP16S2 and integrating input/output ports, Audio PWM, Timer and Low Voltage Reset...etc. on a chip.

Furthermore, CST1602B extend its external device connection capability such as Serial ROM/Flash. The internal memory capacity includes 128Kx16 program/data FLASH plus 3Kx16 working SRAM.



CST1602B 16-bit Speech Processor

2. CST1602B Features

- ◆ High-performance RISC TxP16S2 CPU
 - wide working frequency and voltage 6Mhz ~13Mhz@1.8Volt ~ 5.5Volt
 - Operation frequency is programmable by Software
 - Built-in 3072x16 SRAM
 - Embedded PC Stack Level 16
- ◆ Rich DSP function
 - Hardware Circular Buffer support
 - MAC Computation power : 13 MIPS (max.)
 - Multi-Function Support: In MAC calculation, simultaneously access two operands from memory in one cycle
 - Extend Dynamic Range: A 40-bit accumulator to ensure in 512 successive multiple+additions no overflows
- ◆ Embedded Flash 128Kx16
 - Typical 1,000 erase/program cycles
 - Greater than 10 years Data Retention
- ◆ Software-based audio processing technical
 - Subband , ADPCM , Melody
- ◆ Support 18+2(ICE PAD can be as I/O) general purpose I/O port.
- ◆ Mono 16bit PWM
- ◆ 6 IRQ include 2 external interrupt
- ◆ SPI Master interface
- ◆ Three timers: Timer1, Timer2, RTC timer
- ◆ Support Spread Spectrum clocking to reduce EMI.
- ◆ Watch dog timer (WDT)
- ◆ Low voltage reset (LVR)
- ◆ PB0, PB1, PB2, PB3 support two edge modes for wake-up function are rising and falling edge trigger.
- ◆ IR
- ◆ Low voltage detector
- ◆ **Notice: VCC Decoupling Cap 10uF should be close to IC within 0.5cm.**
- ◆ **Notice: VCC Decoupling Cap 0.1uF should be close to IC within 0.5cm.**
- ◆ **CST1602A 和 CST1602B 的差異如下 :**
 - CST1602B 增加了 Ultra deep sleep 功能
 - CST1602B 解決了 PortC2 / PortC4 / PortC5 / PortC6 / PortC7 不能連接電感性元件的問題



CST1602B 16-bit Speech Processor

3. CST1602B Application Field

- MCU Application
- Electronic Dictionary
- Handheld Games
- Electronic Learning Aid (ELA)
- Electronics storybook

4. CST1602B Block Diagram

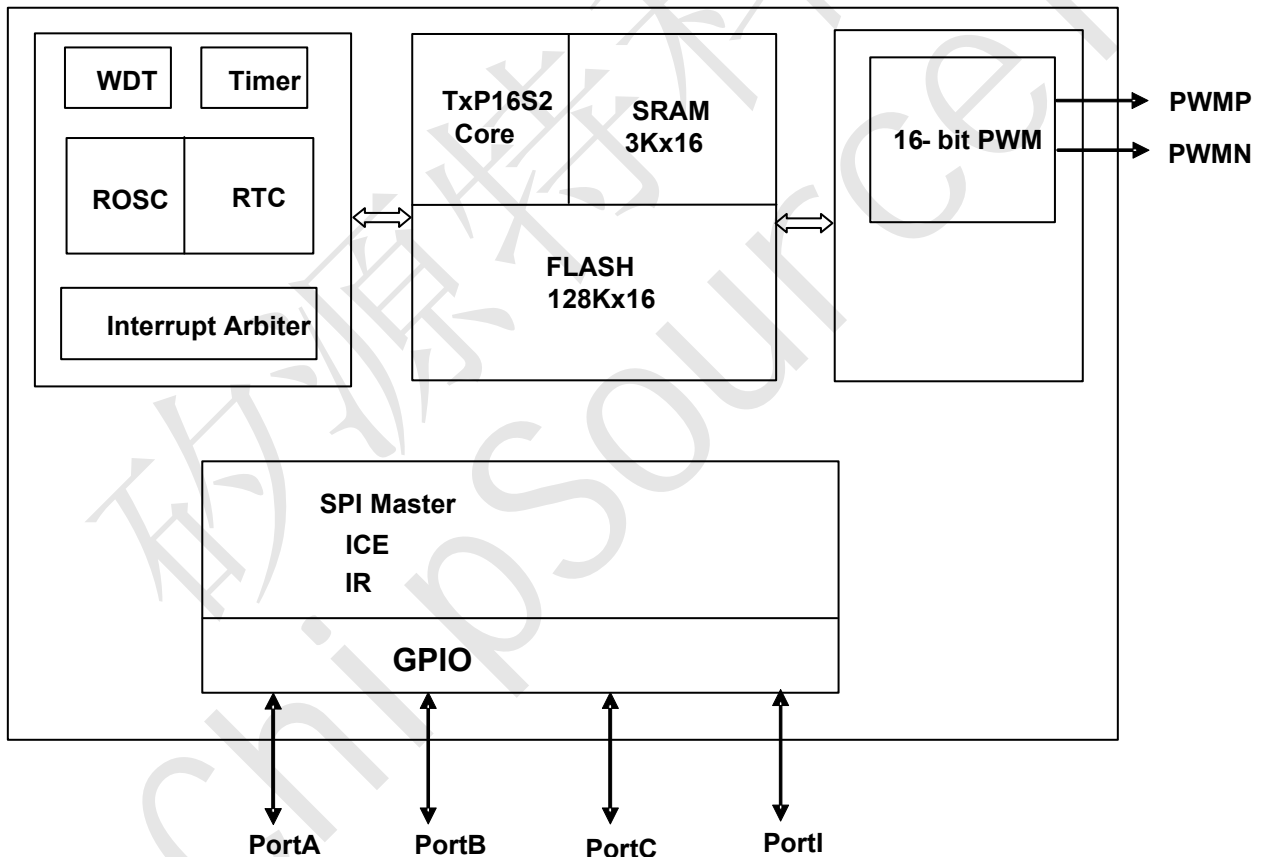

Figure 4.1



CST1602B 16-bit Speech Processor

4.1 Pin Assignments /Description

Pin Name	I/O	State after RESET	FUNCTIONS
Chip Power			
VCC	I	High	Chip Power Input
VSS	I	Low	Digital Ground
General Purpose I/O Port			
PortA[3:0]	I/O	Low	PortA is programmable Input/Output port
PortB[5:0]	I/O	Low	PortB is programmable Input/Output port
PortC[7:0]	I/O	Low	PortC is programmable Input/Output port PortC[2] is programmable Input/Output port when not connected to ICE ICE_VPP: PortC[2] is embedded ICE VPP pin when connected to ICE Probe.
PortI[1]/ ICE_SCLK	I/O	Low	PortI[1] is programmable Input/Output port when not connected to ICE Probe. Internal pull-down R (50K ohm) will be enable at ICE mode. ICE_SCLK: PortI[1] is embedded ICE clock pin when connected to ICE Probe.
PortI[0]/ ICE_SD	I/O	Low	PortI[0] is programmable Input/Output port when not connected to ICE Probe. Internal pull-down R (50K ohm) will be enable at ICE mode. ICE_SD: PortI[0] is embedded ICE data pin when connected to ICE Probe.
PWM Audio			
PWMP	O	Low	Digital PWM output(+)
PWMN	O	Low	Digital PWM output(-)



CST1602B 16-bit Speech Processor

5. CST1602B Function Descriptions

5.1 TxP16S2

As shown in the block diagram in Figure 4.1, the TxP16S2 is a 16-bit data width processing capability and all instructions are operated in one cycle except parameter data ROM(PM) access. The TxP16S2 not only provides general arithmetic such as addition, subtraction, shifter, normalize, and other logical operations, but it also involves MAC and circular buffer operations for complexity digital signal processing.

5.2 TxP16S2 Registers

The TxP16S2 contains of register files are illustrated below:

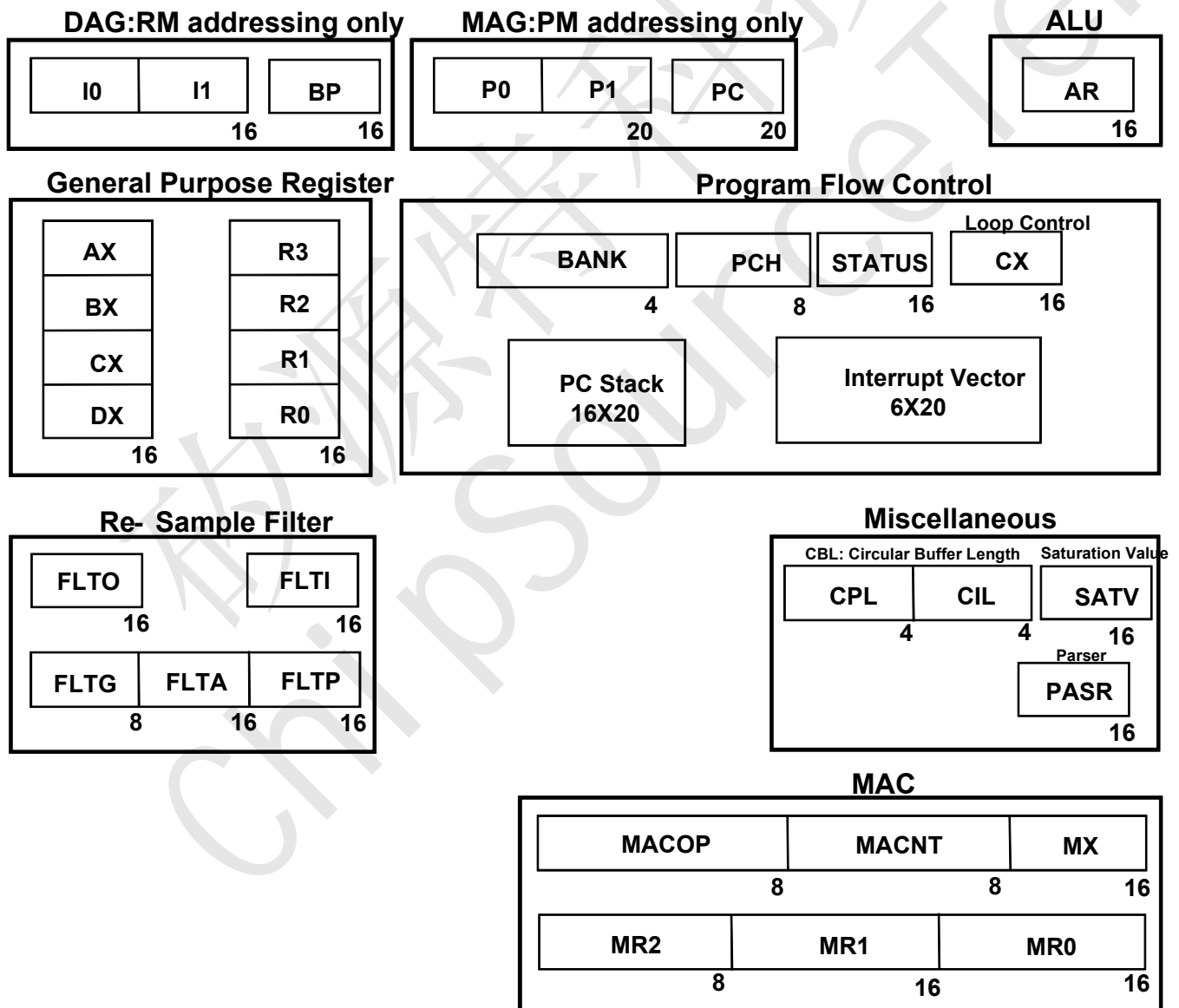

Figure 5.1 TxP16S2 Processor Core Registers



CST1602B 16-bit Speech Processor

REGISTER FILES DEFINE:

AR: Accumulator Register

I0: Index 0 Register

I1: Index 1 Register

BP: Base Pointer Register

P0: Pointer 0 Register

P1: Pointer 1 Register

MACOP: MAC Operation Register

MACNT: MAC Operation Loop Counter

MX: MUL/MAC Input X Register

MR0: MUL/MAC Result Register 0

MR1: MUL/MAC Result Register 1

MR2: MUL/MAC Result Register 2

AX: General AX Register

BX: General BX Register

CX: General CX Register

DX: General DX Register

R0: General R0 Register

R1: General R1 Register

R2: General R2 Register

R3: General R3 Register

CBL: Circular Buffer Length Register

PASR: Parser Register

5.2.1 Special Registers

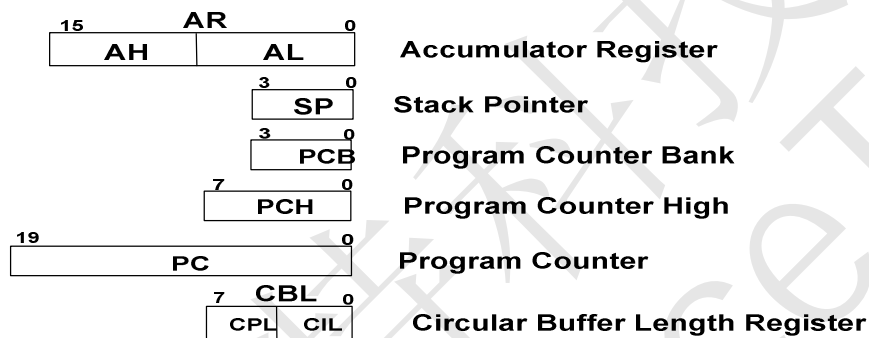

Figure 5.2 TxP16S2 Special Registers

- Accumulator Register

The AR is a general-purpose 16-bit register that stores the result of last arithmetic or logical operation. In addition, any data write to AR will affect the status flag.

- Stack Pointer

The SP is a 4-bit register that is for addressing Stack position. The SP will automatically increment / decrement cause by instruction "CALL" / "RETS", and more detail revealed as the "PC Stack" section.

- Program Counter Bank

The program memory map is divided into 16 banks by PCB register (Program Counter Bank). From BANK2 to BANK15 are system reserved. The BANK0 and BANK1 are implemented as Flash memory.

- Program Counter High

The instruction "LJMP" and "LCALL" will refer PCH and PCB registers to compose of 20-bit pointer provides the 16x64K words PM addressing range.

- Program Counter

The 20-bit PC register provides 16x64K-word addressing capability. It is responsible for MCU fetch now executing instruction.

- Circular Buffer Length Register

Many algorithms such as convolution, correlation, and digital filter require the circular data buffers. The TxP16S2 supports circular buffer operating via the I0 vs. CIL and P0 vs. CPL. The modulus logic implements automatic modulus addressing for accessing RM/PM circular buffer data.



CST1602B 16-bit Speech Processor

5.2.2 Common I/O Registers

The TxP16S2 involves 32 common I/O registers are shown in Table 5.1. There are defined the peripheral IO control and system register.

Symbol	Adr	Reset	RW	B15/b7	b14/b6	b13/b5	b12/b4	B11/b3	B10/b2	b9/b1	b8/b0	Description
STATUS.L	00H	20	R/W	INTEN	-	-	AQ	AN	AV	AC	AZ	System Status Flag
STATUS.H	00H	00	R/W	PA	FA	IntVWR	-	-	-	-	SPIM EN	
INTENA.L	01H	00	R/W	-	-	ENA5	ENA4	ENA3	ENA2	ENA1	ENA0	Interrupt Enable
INTENA.H	01H	00	R/W	-	-	-	-	-	-	-	-	
INTREQ.L	02H	00	R/W	-	-	Req5	Req4	Req3	Req2	Req1	Req0	Interrupt Request
INTREQ.H	02H	00	R/W	-	-	-	-	-	-	-	-	
IntVect	03H	XX	R/W	IntVect[5:0]								Interrupt Vector access Window
IOC_PA	04H	00	R/W	IOC_PA[3:0]								"1" = out, "0" = in of related PA bit
IOC_PB	05H	00	R/W	IOC_PB[5:0]								"1" = out, "0" = in of related PB bit
IOC_PCI.L	06H	00	R/W	IOC_PC[7:0]								"1" = out, "0" = in of related PC bit
IOC_PCI.H	06H	00	R/W	IOC_PI[1:0]								"1" = out, "0" = in of related PI bit
PortA	07H	XX	R/W	PortA[3:0]								Read: in port Write: out port
PortB	08H	XX	R/W	PortB[5:0]								Read: in port Write: out port
PortCI.L	09H	XX	R/W	PortC[7:0]								Read: in port Write: out port
PortCI.H	09H	XX	R/W	PortI[1:0]								Read: in port Write: out port
INTMASK.L	0AH	00	R/W	-	-	Mask5	Mask4	Mask3	Mask2	Mask1	Mask0	Interrupt Mask
INTMASK.H	0AH	00	R/W	-	-	-	-	-	-	-	-	
Reserve	0BH	XX	W									
Reserve	0CH	XX	XX									
Reserve	0DH	XX	XX									
Reserve	0EH	XX	XX									
Reserve	0FH	XX	XX									
Reserve	10H	XX	XX									
Reserve	11H	XX	XX									
Reserve	12H	XX	XX									
Reserve	13H	XX	XX									
Reserve	14H	XX	XX									
Reserve	15H	XX	XX									
Audio-PWM	16H	XX	W	Audio-PWM[15:0]								PWM Audio Channel
Reserve	17H	XX	W									
MISC5.L	18H	00	R/W	THO	LVDO	-	-	-	-	-	-	System Miscellanea register #5
MISC5.H	18H	00	R/W									
MISC4.L	19H	00	R/W	TOUCH REALT	TINT _EN	TIS	SVT	THEN	PREC	-	-	System Miscellanea register #4
MISC4.H	19H	00	R/W									
MISC3.L	1AH	00	R/W	D2ENB	LVDEN	-	-	-	-	-	-	System Miscellanea register #3
MISC3.H	1AH	00	R/W	-	-	-	LVD					
Reserve	1BH	XX	XX									
MISC1.L	1CH	00	R/W	TCS	-	PWM MUTE	-	RC RST	EXRST	LVR	WDT	System Miscellanea register #1
MISC1.H	1CH	00	R/W	CLR RealT	-	-	RTC WAKE	IR_EN	-	PWM EN	MODX	
ClrWDT	1DH	XX	W									Clear WDT
IOP_IX	1EH	XX	W	IOPIX[7:0]								Programming IO Port index
IOP_DAT	1FH	XX	W	IOPD[15:0]								Programming IO Port Data

Table 5.1 Common I/O registers



CST1602B 16-bit Speech Processor

5.2.3 Basic System Registers

◆STATUS register

Symbol	Adr	Reset	RW	b15/b7	b14/b6	b13/b5	b12/b4	b11/b3	B10/b2	b9/b1	b8/b0	Description
STATUS.L	00H	20	R/W	INTEN	-	-	AQ	AN	AV	AC	AZ	System Status Flag
STATUS.H	00H	00	R/W	PA	FA	IntVWR	-	-	-	-	SPIM_EN	

The Status register provides two main functions, the first system flag holds the status information generated by the computational blocks of the TxP16S2, which used for program sequencer control. The second indicated that special function of hardware module is enable or not.

For program flow control:

System Flag	Definition
AZ	ALU or AR Result Zero
AN	ALU or AR Result Negative
AV	ALU Overflow
AC	ALU Carry
PA	Parser Queue available(Read only)
FA	Filter buffer available(Read only)

System hardware control:

System Flag	Definition
INTEN	System global interrupt control bit
IntVWR	Interrupt Vector Table access window control bit
SPIM_EN	SPI master interface control bit

- ◆ Address 01H, 02H and 0AH: Interrupt control registers, the detail are illustrated in Interrupt section.
- ◆ Address 04H~15H: GPIO registers, the detail are illustrated in GPIO section.
- ◆ Address 16H~17H: Audio-PWM control registers, the detail are illustrated in AUDIO section.

◆System Miscellanea register #1

Symbol	Adr	Reset	RW	b15/b7	b14/b6	b13/b5	b12/b4	b11/b3	B10/b2	b9/b1	b8/b0	Description
MISC1.L	1CH	00	R/W	TCS	-	PWM MUTE	-	RC RST	EXRST	LVR	WDT	System miscellanea register #1
MISC1.H	1CH	00	R/W	CLR_RealT	-	-	RTC WAKE	IR_EN	-	PWM_EN	MODX	

Item	Description
Clr_RealT	Set high to clear 32-bit RealT timer. (this bit only for TCS=1)
RTC_WAKE	RTC Wake Up Flag (Read Only)
IR_EN	IR 38K Enable
PWM_EN	Audio PWM enable
MODX	MODX=0 is chosen narrowband sound-effect filter. MODX =1 is chosen wideband sound-effect filter. Actual bandwidth is dependent on source signal sample-rate.
TCS (Note2*)	Enable RealT Timer
PWM_MUTE	Audio PWM mute enable
RC_RST (Note1*)	System Reset from internal RC reset
EXRST	System Reset from external reset pin
LVR	System Reset from low voltage reset
WDT	System Reset from watch dog reset



CST1602B 16-bit Speech Processor

Note1: RC_RST, EXRST, LVR will clear WDT bits, except for WDT is set to 1. All of the reset status bits can be set or cleared in software. Setting one of these bits in software does not cause a device reset.

Note2: If programmer read the "RealT" register, it can get 32-bit timer based on 30.517ns(32.768MHz). An example is shown as follows.

```
io[RealT] = ar          ; write to reset the state machine of 32-bit real timer.
ar         = io[RealT]  ; read low-word timer[15:0]
ar         = io[RealT]  ; read high-word timer[31:16]
```

◆ System Miscellanea register #3

Symbol	Adr	Reset	RW	b15/b7	b14/b6	b13/b5	b12/b4	b11/b3	B10/b2	b9/b1	b8/b0	Description
MISC3.L	1AH	00	R/W	D2ENB	LVDEN	-	-	-	-	-	-	System miscellanea register #3
MISC3.H	1AH	00	R/W	-	-	-	LVD				-	

Item	Description
LVD	Default:0 , LVD voltage 1.8~ 2.98V for D2ENB=0(each step~ 40mV), 2.7V~4.47V for D2ENB=1(each step~ 60mV)
D2ENB	Default:0 , VCC divide 2 for LVD input
LVDEN	Default:0 , LVD Enable

◆ System Miscellanea register #4

Symbol	Adr	Reset	RW	b15/b7	b14/b6	b13/b5	b12/b4	b11/b3	B10/b2	b9/b1	b8/b0	Description
MISC4.L	19H	00	R/W	TOUCH REALT	TINT _EN	TIS	SVT	THEN	PREC	-	-	System miscellanea register #4
MISC4.H	19H	00	R/W									

Item	Description
TOUCH_REALT	Touch with Real-T function 0:disable & clear real-T stop flag 1:enable
TINT_EN	Touch INT Enable
TIS	Touch I/O Port input select , 00: NA, 01:PortA, 10: NA, 11:PortC
SVT	Touch SVT , 0: 1/4*VCC, 1: 1/2*VCC
THEN	Touch Enable
PREC	Touch Pre-charge 1.5V

◆ System Miscellanea register #5

Symbol	Adr	Reset	RW	b15/b7	b14/b6	b13/b5	b12/b4	b11/b3	B10/b2	b9/b1	b8/b0	Description
MISC5.L	18H	00	R/W	THO	LVDO	-	-	-	-	-	-	System Miscellanea register #5
MISC5.H	18H	00	R/W									

Item	Description
THO	TOUCH Output (Read Only)
LVDO	LVD Output (Read Only)



CST1602B 16-bit Speech Processor

◆ Virtual Programming IO

Symbol	Adr	Reset	RW	b15/b7	b14/b6	b13/b5	b12/b4	b11/b3	B10/b2	b9/b1	b8/b0	Description	
VIO_IX	1EH	XX	W	-	-	-	IOPIX4	IOPIX3	IOPIX2	IOPIX1	IOPIX0	Programming IO Port index	
VIO_DATA	1FH	XX	W	IOPD[15:0]									Programming IO Port Data

Table 5.2 Virtual Programming IO

The operation steps of these group register, first select virtual IO port index then write data to programming IO port.

Virtual Programming IO Port

Symbol	Adr	Reset	RW	b15/b7	b14/b6	b13/b5	B12/b4	b11/b3	B10/b2	b9/b1	b8/b0	Description
Timer1	00H	00	W	Timer0								Timer1
Timer1	00H	00	R	Current Timer1 Value								
Timer2	01H	00	W	Timer1								Timer2
Timer2	01H	00	R	Current Timer2 Value								
RTCTimer	02H	00	RW	RTCTimer								RTC Timer
FetchCNT	03H	00	W	-	-	-	-	-	-	Fetch Timer2	Fetch Timer1	Fetch Timer1/2 Current Value
Reserved	04H	-	-									
PA_PD50K	05H	00	W	PA_PD50K[3:0]								PortA Pull Down 50K Enable
PB_PD50K	06H	00	W	PB_PD50K[5:0]								PortB Pull Down 50K Enable
PCI_PD50K.L	07H	00	W	PC_PD50K[7:0]								PortCI Pull Down 50K Enable
PCI_PD50K.H	07H	CO	W	PI_PD50K[1:0]	-	-	-	-	-	-	-	PortCI Pull Down 50K Enable (PortI default : Enable PD50K)
PA_PD220K	08H	00	W	PA_PD220K[3:0]								PortA Pull Down 220K Enable
PB_PD220K	09H	00	W	PB_PD220K[5:0]								PortB Pull Down 220K Enable
PCI_PD220K.L	0AH	00	W	PC_PD220K[7:0]								PortCI Pull Down 220K Enable
PCI_PD220K.H	0AH	00	W	PI_PD220K[1:0]	-	-	-	-	-	-	-	PortCI Pull Down 220K Enable
PA_PD1M	0BH	00	W	PA_PD1M[3:0]								PortA Pull Down 1M Enable
PB_PD1M	0CH	00	W	PB_PD1M[5:0]								PortB Pull Down 1M Enable
PCI_PD1M.L	0DH	00	W	PC_PD1M[7:0]								PortCI Pull Down 1M Enable
PCI_PD1M.H	0DH	00	W	PI_PD1M[1:0]	-	-	-	-	-	-	-	PortCI Pull Down 1M Enable
PA_TOUCH	0EH	00	W	PA_Touch_EN[3:0]								PortA Touch Enable
PB_TOUCH	0FH	00	W	PB_Touch_EN[5:0]								PortB Touch Enable
PCI_TOUCH.L	10H	00	W	PC_Touch_EN[7:0]								PortCI Touch Enable
PCI_TOUCH.H	10H	00	W	PI_Touch_EN[1:0]	-	-	-	-	-	-	-	PortCI Touch Enable
Reserved	11H	-	-									
Reserved	12H	-	-									
Reserved	13H	-	-									
WAKEN_PA	14H	00	W	PortA_WAKEN[3:0]								PortA WAKE UP Enable
WAKEN_PB	15H	00	W	PortB_WAKEN[5:0]								PortB WAKE UP Enable
WAKEN_PC	16H	00	W	PortC_WAKEN[7:0]								PortC WAKE UP Enable
WAKELV_PA	17H	00	W	PortA_WAKELV[3:0]								PortA WAKE UP Edge "1" = Pos-Edge, "0" = Neg-Edge of related PA bit
WAKELV_PB	18H	00	W	PortB_WAKELV[5:0]								PortB WAKE UP Edge "1" = Pos-Edge, "0" = Neg-Edge of related PA bit
WAKELV_PC	19H	00	W	PortC_WAKELV[7:0]								PortC WAKE UP Edge "1" = Pos-Edge, "0" = Neg-Edge of related PC bit
WAKEDLV_PB	1AH	00	W	PortB_WAKEDLV[3:0]								PortB0 ~ PortB3 Double-Edge WAKE UP Enable
DEEP_SLEEP2.L	1FH	04	R/W	-	-	-	-	-	VDD1EN	CLK	DSENIEN	Deep Sleep2 Status Register[7:0]
DEEP_SLEEP2.H	1FH	00	R/W	DSENO	-	-	-	-	WAKE[3:0]			Deep Sleep2 Status Register[15:8]



CST1602B 16-bit Speech Processor

5.3 PC Stack

The PC STACK is TxP16S2 special embedded memory used to save (PC+1) value, which is composed with 8-level.

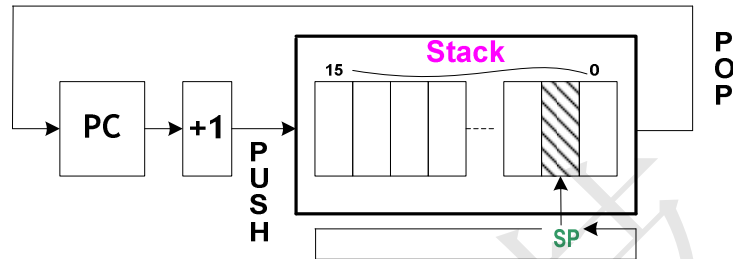

Figure 5.3 PC Stack Structure

Stack's top value is indexed by stack pointer (SP) register. When CALL instruction is executed, then the (PC+1) will PUSH onto stack addressing by SP and it will auto decrement. At the end of subroutine when RETS instruction is executed the SP will auto increment and stack content of pointer by SP will POP into PC.

The contents of STACK and SP are neither readable nor writeable by instruction. The SP is initialized to "0" after RESET.

5.4 Interrupt

5.4.1 Interrupt Vector Table

The Interrupt Vector Table is TxP16S2 special embedded memory, which is composed with 6-level of FIFO, used to store the index of interrupt service routine (ISR) address. User can access Interrupt Vector Table by read/write IntVect I/O register, which refers PCB register to compose of 20-bit address.

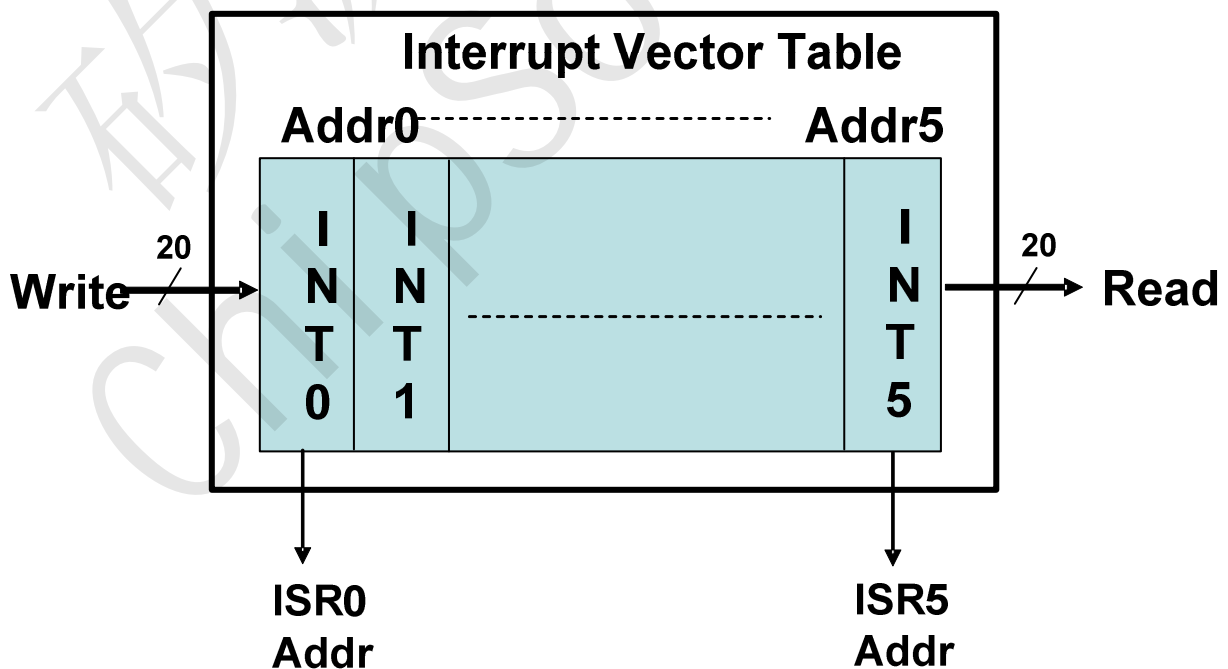

Figure 5.4 Interrupt Vector Structure



CST1602B 16-bit Speech Processor

5.4.2 Interrupt Controller

Common I/O registers

Symbol	Adr	Reset	RW	B7	B6	B5	B4	B3	B2	B1	B0	Description
STATUS	00H	00	R/W	INTEN	-	-	-	AN	AV	AC	AZ	System Status Flag
INTENA.L	01H	00	R/W	-	-	ENA5	ENA4	ENA3	ENA2	ENA1	ENA0	Interrupt Enable
INTENA.H	01H	00	R/W	-	-	-	-	-	-	-	-	
INTREQ.L	02H	00	R/W	-	-	Req5	Req4	Req3	Req2	Req1	Req0	Interrupt Request
INTREQ.H	02H	00	R/W	-	-	-	-	-	-	-	-	
INTMASK.L	0AH	00	R/W	-	-	Mask5	Mask4	Mask3	Mask2	Mask1	Mask0	Interrupt Mask
INTMASK.H	0AH	00	R/W	-	-	-	-	-	-	-	-	

This chip provides several interrupt sources, including internal Audio PWM, Timer1, Timer2, RTC, SPI master, Flash ready, Touch, and 2 external ExtINT0, ExtINT1, interrupts. More details control will describe as follows:

Interrupt Source	Interrupt Vector	Priority
Audio PWM Timer	0H	INT0_IRQ (highest)
Timer1 / ExtINT0 / SPI Master (Note)	1H	INT1_IRQ
Timer2 / ExtINT1 / SPI Master (Note)	2H	INT2_IRQ
RTC Timer / SPI Master (Note)	3H	INT3_IRQ
Reserved	4H	INT4_IRQ
Touch / SPI Master (Note)	5H	INT5_IRQ (lowest)

Table 5.3 Interrupt Sources

Note: Only one interrupt source can be selected for each interrupt vector.

(a) Global interrupt enable (INTEN)

The global interrupt INTEN controls the enable/disable of all interrupts. When INTEN is cleared to "0", all interrupts are disabled. When INTEN is set to "1", all interrupts are enabled (but still dependent on value of INTENA register). The INTEN is initialized to "0" after power on.

(b) Interrupt enable (INTENA)

The interrupt enable from ENA5 to ENA0 are shown in above. An interrupt is allowed when these control bit are set to "1", and interrupt is inhibit when these control bit are cleared to "0". They are all initialized to "0" after power on.

(c) Interrupt request (INTREQ)

If an interrupt raising edge request is generated, the related interrupt request bit is set to "1" by hardware and waits for interrupt accept. INTREQ can be cleared to "0" by software. Hardware will not clear this bit. INTREQ are all initialized to "0" after power on.

(d) Interrupt mask (INTMASK)

The interrupt can be masked by setting bit5~ bit0 of interrupt mask register as above. Each interrupt source in the system can be masked individually.

(e) Interrupt Priority

INT0_IRQ (highest) > INT1_IRQ > INT2_IRQ > INT3_IRQ > INT4_IRQ > INT5_IRQ (lowest)



CST1602B 16-bit Speech Processor

5.4.3 Interrupt Processing

When any interrupt request(INTREQ) is generated, the acceptance of interrupt is decided by the interrupt enable(ENA) and global interrupt enable(INTEN). If the global interrupt enable(INTEN), related interrupt enable bit(ENA) are set to "1" and related mask bit(MASK) are cleared to 0, that interrupt will be accepted on the next clock. These following procedures will automatically be done in one clock cycle by hardware showing below:

- (1) Program Counter(PC), PCB, PCH, AR and FLAG will be stored in special hardware registers.
- (2) PC will be set to the corresponding interrupt entry address by refer to interrupt vector table.
- (3) The global interrupt enable (INTEN) is cleared to "0", which avoids the nest interrupt happened.

When interrupt service routine was finished, an RETI instruction will perform the procedures by hardware showing as follows:

- (1) Restore the stored PC, PCB, PCH, AR and FLAG.
- (2) The global interrupt enable (INTEN) is set to "1", which allows to accept the subsequent interrupt.

Before executing RETI instruction, the corresponding interrupt request (INTREQ) bit must be cleared to "0" by software. If the request bit is not cleared, the same interrupt will be accepted again.



CST1602B 16-bit Speech Processor

5.5 MAC (16-bit X 16-bit Multiplier and Accumulator)

A 16 bit x 16 bit MAC is provided for digital signal processing. The core of MAC operation is multiply MX&MY with 2'S complement operand and accumulation previous 40-bit MF then rounding store result in the 40-bit MR register. The basic MAC architecture is shown as Figure 5.5.

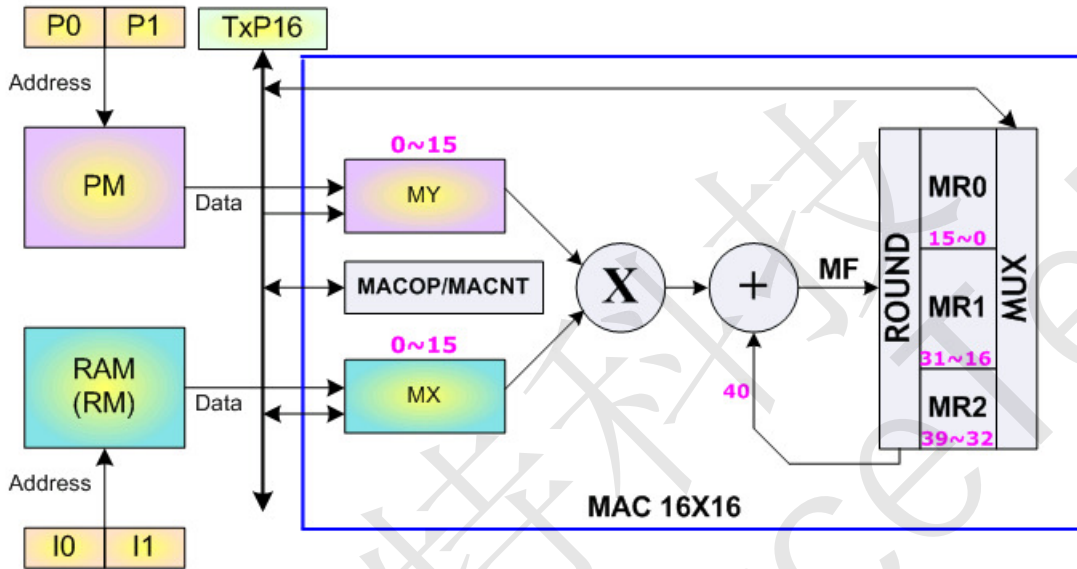

Figure 5.5 MAC Architecture

Define MAC module registers:

MX: MAC input 16-bit X register

MR: Multiplier or MAC result 40-bit register

MACOP: MAC operation define register

Symbol	Reset	RW	B7	B6	B5	B4	B3	B2	B1	B0	Description
MACOP	00	R/W	RND1	RND0	P0/P1	POP:+/-	I0/I1	IOP:+/-	MY:SU(01)	MX:SU(01)	MAC Operation Setup

MACNT: MAC equation loop counter, max to 255

Basically, multiplier operates equation:

$$MR = MX * MY(SU) \rightarrow MX: \text{signed}, MY: \text{unsigned}$$

Permission MY is AR or immediate value (-128~127), MX and MY are signed or unsigned assign by MACOP. So, actual multiplier instruction likes this:

$$MR = MX * AR \quad \text{or} \quad MR = MX * 56$$

The operation of MAC equation is:

$$MR = MR + (MX * MY(SU)) \ll RND, MX = RM[I0++], MY = PM[P1--]$$

The means of equation is signed MX multiply unsigned MY the result value shift left RND bits and add previous MR then write back to MR.

Simultaneously, load new value to MX fixed from RM[index operation]



CST1602B 16-bit Speech Processor

MY fixed from PM[pointer operation]

Therefore, MAC array operation like this:

$$MR = MR + (MX * MY(SS)) \ll 1, MX = RM[I0++], MY = PM[P1--]$$

$$MR = MR + (MX * MY(SS)) \ll 1, MX = RM[I0++], MY = PM[P1--]$$

·
·
·

$$MR = MR + (MX * MY(SS)) \ll 1, MX = RM[I0++], MY = PM[P1--]$$

Successive 64 times

Actual just one line of instruction present in assembly coding like this:

$$MACNT = 63$$

This is very benefit for reducing code size. Of course, we need setup MACOP register previous; at this example is like this;

Symbol	Reset	RW	B7	B6	B5	B4	B3	B2	B1	B0	Description
MACOP	00	R/W	RND1	RND0	P0/P1	POP:+/-	I0/I1	IOP:+/-	MY:SU(01)	MX:SU(01)	MAC Operation Setup
			0	1	1	1	0	0	0	0	

Note: Successive MAC operation will cause MCU interrupt disable.



CST1602B 16-bit Speech Processor

6. CST1602B Memory Configuration

6.1 Internal Program/Parameter Memory

TxP16S2 consider both instruction and data ROM are the same as program ROM(PM), so it's very flexible and efficient for instruction and data memory allocation in PM. The total of logical PM space is 16 banks. Each bank has 64 K space. The 16 x 64K space is addressed by memory address generator unit (MAG). The BANK0 and BANK1 are implemented as Flash memory. From BANK2 to BANK15 are system reserved. More details control will describe as follows:

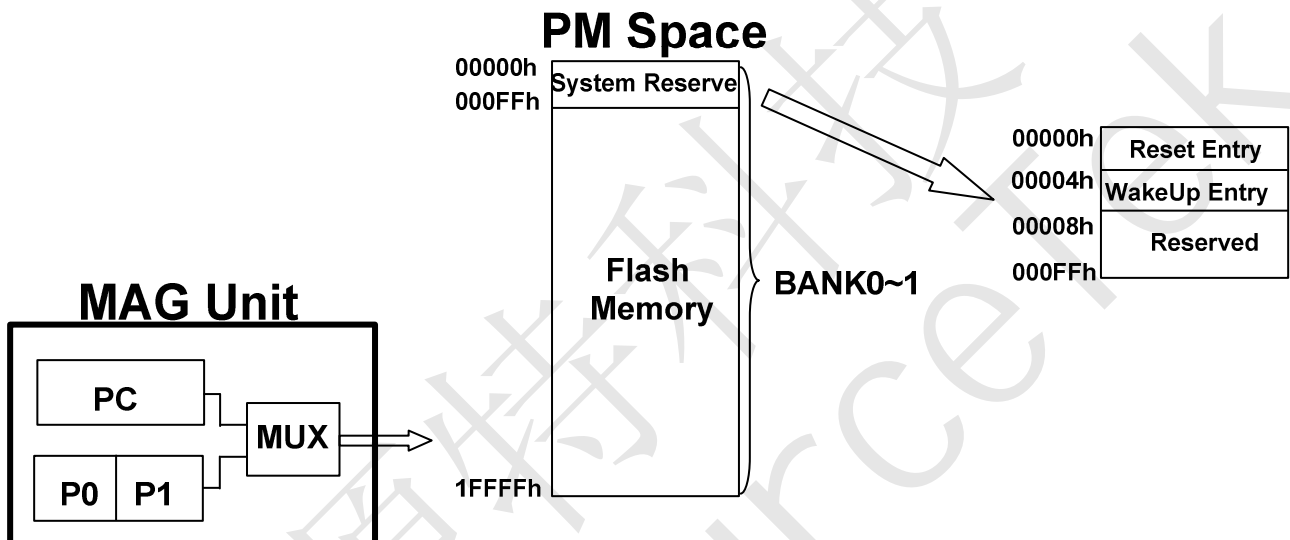
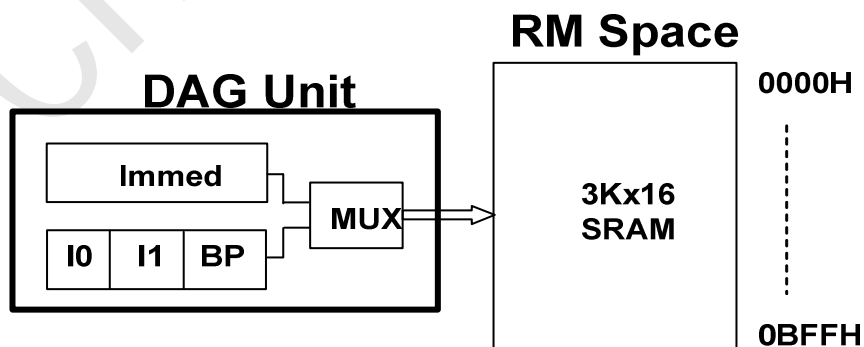

Figure 6.1 PM block diagram

When TxP16S2 executed an instruction, the PM address is generated from PC register. Similarity, when it access a word data, the PM address is composed with 20-bit from P0 or P1.

6.2 Internal Data Working SRAM

The internal data working ram space is totally 3Kx16-bit that named as RM. Addressing ranged from 0x0000 through 0x0BFF, which is generated by Data Address Generator Unit (DAG). Note: Index register (I0,I1,BP) are 16-bit width, but RM address line is only 12-bit width(0~3071); therefore, RM address will be warping when index value exceed 4095.





CST1602B 16-bit Speech Processor

Figure 6.2 RM block diagram

6.3 Data Stack

A Last In First Out (LIFO) STACK is implementation for temporary data storage in RM memory. Generally, Data Stack is start-up at the bottom of RM, so BP is usually set to 0x0BFF.

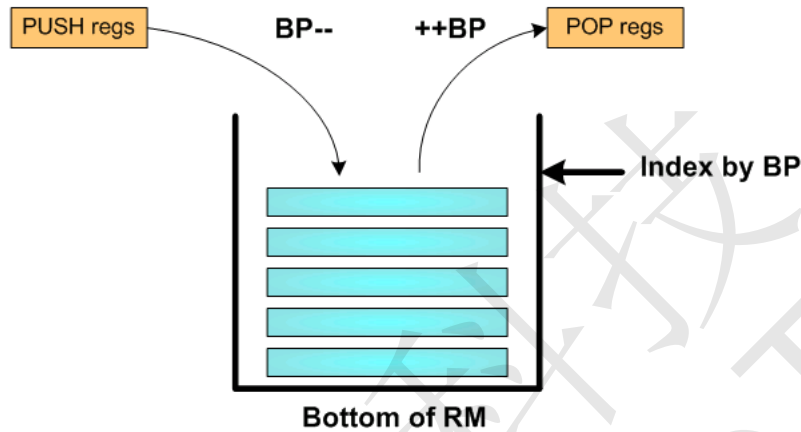

Figure 6.3 Data Stack Structure

Data Stack's top value is indexed by base pointer (BP) register. When PUSH instruction is executed, the "regs" will PUSH onto stack which address by BP and it will auto decrement. If POP instruction is performed, the BP will auto increment and stack content of pointed by BP will POP into "regs".



CST1602B 16-bit Speech Processor

7. CST1602B Peripherals

7.1 Programmable Timers

Common I/O registers

Symbol	Adr	Reset	RW	B7	B6	B5	B4	B3	B2	B1	B0	Description
STATUS.L	00H	20	R/W	INTEN	-	-	AQ	AN	AV	AC	AZ	System Status Flag
STATUS.H	00H	00	R/W	PA	FA	IntVWR	-	-	-	-	SPIM EN	
INTENA.L	01H	00	R/W	-	-	ENA5	ENA4	ENA3	ENA2	ENA1	ENA0	Interrupt Enable
INTENA.H	01H	00	R/W	-	-	-	-	-	-	-	-	
INTREQ.L	02H	00	R/W	-	-	Req5	Req4	Req3	Req2	Req1	Req0	Interrupt Request
INTREQ.H	02H	00	R/W	-	-	-	-	-	-	-	-	

Virtual Programming IO Port

Symbol	Adr	Reset	RW	b15/b7	b14/b6	b13/b5	B12/b4	b11/b3	B10/b2	b9/b1	b8/b0	Description
Timer1	00H	00	W	Timer0								Timer1
Timer1	00H	00	R	Current Timer1 Value								
Timer2	01H	00	W	Timer1								Timer2
Timer2	01H	00	R	Current Timer2 Value								
RTCTimer	02H	00	RW	RTCTimer								RTC Timer
FetchCNT	03H	00	W	-	-	-	-	-	-	Fetch Timer2	Fetch Timer1	Fetch Timer1/2 Current Value

7.1.1 Audio PWM Timer

Audio PWM timer generate 32KHz or 64KHz or 128KHz interrupt request when INTENA0 bit is turned on, *If Auto FIFO_EN is setting the interrupt request rate = $F_t / \text{FIFO_Length}$.* **Notice: It should be avoided that INTENA bit0 is turned on/off quickly. If need to turned on/off INTENA bit0 quickly, recommend to use INTMASK bit0.**

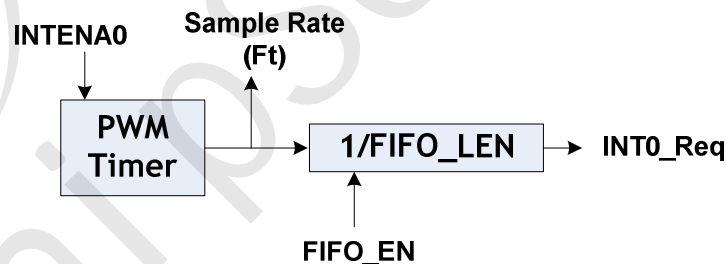

Figure 7.1 Audio PWM Timer Structure

7.1.2 Timer1 & Timer2

The clock source of Timer1 & Timer2 comes from fixed 32.768Mhz or External Clock Input, It contains 16-bit write-only counter register. If Timer enable correspond with the INTENA bit is turned on then counting to time out, an interrupt request will be generated. At the same time, TnC will be reloaded into Timer register and up-count again. If the global interrupt enable, an interrupt signal is generated at the next clock.



CST1602B 16-bit Speech Processor

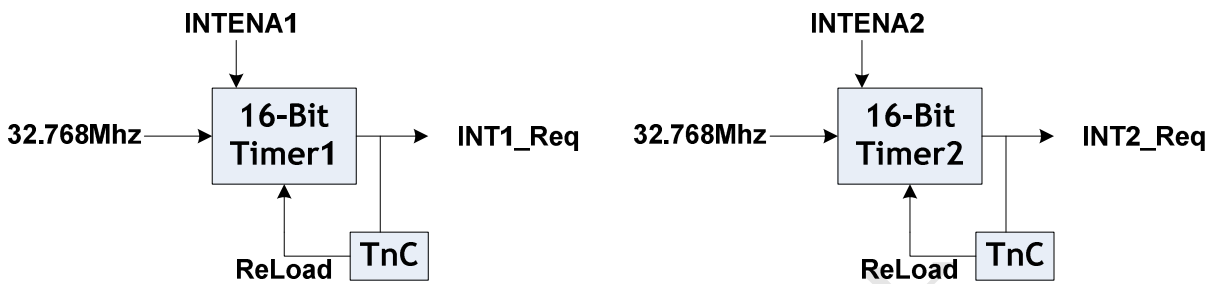

$$\text{Int1_Req} / \text{Int2_Req} = (32.768\text{Mhz}) / (\text{TnC}+1)$$

Figure 7.2 Timer1 & Timer2 Structure

7.1.3 RTC(Real Time Clock) Timer

The RTC Timer input frequency is Low power RC oscillator 32768Hz $-5\% @ 2.0\text{V} \sim +15\% @ 5.0\text{V}$ (LP32K). It contains 16-bit counter register. RTC generates interrupt request or wake-up MCU when in halt mode or interrupt in normal mode. The wake-up function can be disabled by option.

The frequency of Int3_Req = 32768Hz / (RTC Timer TnC+1)

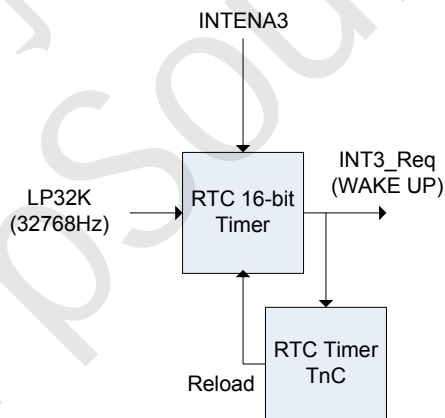

Figure 7.3 RTC Timer Structure



CST1602B 16-bit Speech Processor

7.2 General Purpose I/O Ports

The CST1602B provides 4 I/O ports for user application. There are four I/O port, PA0~PA3, PB0~PB5, PC0~PC7 and PI0~PI1. The input/output bits programmable by IOC control register respectively. PA0~PA3, PB0~PB5, PC0~PC7 wake-up function enable or disable by user program. PA1 and PA2 are external interrupt pins. The Pull-Down 50K or 220K or 1M resistor of each pin can be programmed by user program. **If I/O pin is set to output pin, the Pull-Down 50K and Pull-Down 1M resistor will be disable.**

The basic I/O schematic is showed in Figure 7.5.

Common I/O registers

Symbol	Adr	Reset	RW	B15/b7	b14/b6	b13/b5	b12/b4	B11/b3	B10/b2	b9/b1	b8/b0	Description		
IOC_PA	04H	00	R/W				IOC_PA[3:0]						"1" = out, "0" = in of related PA bit	
IOC_PB	05H	00	R/W				IOC_PB[5:0]						"1" = out, "0" = in of related PB bit	
IOC_PC.L	06H	00	R/W				IOC_PC[7:0]						"1" = out, "0" = in of related PC bit	
IOC_PC.H	06H	00	R/W	IOC_PI[1:0]										"1" = out, "0" = in of related PI bit
PortA	07H	XX	R/W				PortA[3:0]						Read: in port Write: out port	
PortB	08H	XX	R/W				PortB[5:0]						Read: in port Write: out port	
PortCI.L	09H	XX	R/W				PortC[7:0]						Read: in port Write: out port	
PortCI.H	09H	XX	R/W	PortI[1:0]										Read: in port Write: out port

Virtual Programming IO Port

Symbol	Adr	Reset	RW	b15/b7	b14/b6	b13/b5	B12/b4	b11/b3	B10/b2	b9/b1	b8/b0	Description		
PA_PD50K	05H	00	W				PA_PD50K[3:0]						PortA Pull Down 50K Enable	
PB_PD50K	06H	00	W				PB_PD50K[5:0]						PortB Pull Down 50K Enable	
PCI_PD50K.L	07H	00	W				PC_PD50K[7:0]						PortCI Pull Down 50K Enable	
PCI_PD50K.H	07H	C0	W	PI_PD50K[1:0]										PortCI Pull Down 50K Enable (PortI default : Enable PD50K)
PA_PD220K	08H	00	W				PA_PD220K[3:0]						PortA Pull Down 220K Enable	
PB_PD220K	09H	00	W				PB_PD220K[5:0]						PortB Pull Down 220K Enable	
PCI_PD220K.L	0AH	00	W				PC_PD220K[7:0]						PortCI Pull Down 220K Enable	
PCI_PD220K.H	0AH	00	W	PI_PD220K[1:0]										PortCI Pull Down 220K Enable
PA_PD1M	0BH	00	W				PA_PD1M[3:0]						PortA Pull Down 1M Enable	
PB_PD1M	0CH	00	W				PB_PD1M[5:0]						PortB Pull Down 1M Enable	
PCI_PD1M.L	0DH	00	W				PC_PD1M[7:0]						PortCI Pull Down 1M Enable	
PCI_PD1M.H	0DH	00	W	PI_PD1M[1:0]										PortCI Pull Down 1M Enable
PA_TOUCH	0EH	00	W				PA_Touch_EN[3:0]						PortA Touch Enable	
PB_TOUCH	0FH	00	W				PB_Touch_EN[5:0]						PortB Touch Enable	
PCI_TOUCH.L	10H	00	W				PC_Touch_EN[7:0]						PortCI Touch Enable	
PCI_TOUCH.H	10H	00	W	PI_Touch_EN[1:0]										PortCI Touch Enable
Reserved	11H	-	-											
Reserved	12H	-	-											
Reserved	13H	-	-											
WAKEN_PA	14H	00	W				PortA_WAKEN[3:0]						PortA WAKE UP Enable	
WAKEN_PB	15H	00	W				PortB_WAKEN[5:0]						PortB WAKE UP Enable	
WAKEN_PC	16H	00	W				PortC_WAKEN[7:0]						PortC WAKE UP Enable	
WAKELV_PA	17H	00	W				PortA_WAKELV[3:0]						PortA WAKE UP Edge "1" = Pos-Edge, "0" = Neg-Edge of related PA bit	
WAKELV_PB	18H	00	W				PortB_WAKELV[5:0]						PortB WAKE UP Edge "1" = Pos-Edge, "0" = Neg-Edge of related PA bit	
WAKELV_PC	19H	00	W				PortC_WAKELV[7:0]						PortC WAKE UP Edge "1" = Pos-Edge, "0" = Neg-Edge of related PC bit	
WAKEDLV_PB	1AH	00	W				PortB_WAKEDLV[3:0]						PortB0 ~ PortB3 Double-Edge WAKE UP Enable	

These totally 20 I/O pins work not only just a general input/output port function but also can be configured as



CST1602B 16-bit Speech Processor

SPI master, Analog input, IR 38K, External interrupt etc. For more detail please refer to relative section.

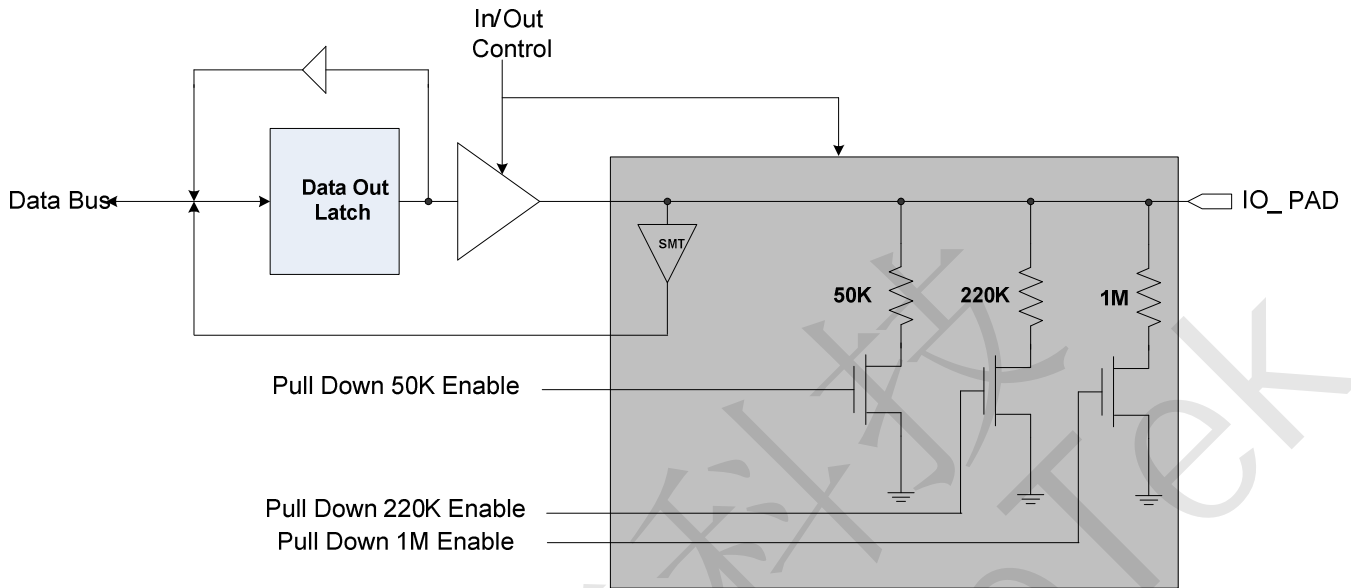

Figure 7.4 Basic I/O Configuration

Virtual Programming IO Port

Symbol	Adr	Reset	RW	b15/b7	b14/b6	b13/b5	B12/b4	b11/b3	B10/b2	b9/b1	b8/b0	Description
WAKEDLV_PB	1AH	00	W	PortB_WAKEDLV[3:0]							PortB0 ~ PortB3 Double-WAKE UP Enable	

PB0, PB1, PB2 and PB3 support two edge mode which is rising and falling edge trigger for wake-up function. The rising and falling edge trigger is selected by user program.



CST1602B 16-bit Speech Processor

7.3 Extension Device

CST1602B built-in special hardwires for external device connection capability are listed below:

7.3.1 SPI Master Controller

In order to enable SPI Master Controller interface, user should set STATUS.b8 = 1 before SPI Master Controller operation.

7.3.1.1 Features

- Serial clock rate: 16.384 MHz / 8.192 MHz / 4.096 MHz
- Support four standard SPI modes
- Built in 1x16 bits data buffer

I/O Port	SPI interface	Direction	Description
PortB.2	SO	I/O	Serial Data output
PortB.1	SI	I/O	Serial Data input
PortB.0	SCK	O	Serial Clock
PortB.5	CS	O	Chip Select(free assign by user)

7.3.1.2 Control/Data Registers

Symbol	Adr	Reset	RW	b15/b7	B14/b6	b13/b5	b12/b4	b11/b3	B10/b2	b9/b1	b8/b0	Description
CTRL_W.L	55H	01	W	-	-	RCV	SEND	-	-	Total Byte		Write Control Register Low Byte
CTRL_W.H	55H	00	W	CPOL	CPHA	CKSEL		ICS	-	Which_INT		Write Control Register High Byte
CTRL_R.L	55H	01	R	DATOK	0	RCV	SEND	0	0	Total Byte		Read Control Register Low Byte
CTRL_R.H	55H	00	R	CPOL	CPHA	CKSEL		ICS	0	Which_INT		Read Control Register High Byte

Total Send/Receive Byte	Default:1 , Total byte number of sending or receiving
SEND	Trigger sending data
RCV	Trigger receiving data.
Which_INT	Default:0 , assign SPI interrupt to which interrupt vector , 00:int1 01:int2 10:int3 11:int5
ICS	Internal SPI command select enable
CKSEL	00: N/A , 01: 16.384MHz , 10: 8.192 MHz , 11: 4.096 MHz
CPHA	Clock Phase
CPOL	Clock Polarity
DATOK	Indicate transmit/receive data O.K

SPI Modes

SPI Mode	Conditions	Leading Edge	Trailing eDge
0	CPOL=0, CPHA=0	Sample (Rising)	Setup (Falling)
1	CPOL=0, CPHA=1	Setup (Rising)	Sample (Falling)
2	CPOL=1, CPHA=0	Sample (Falling)	Setup (Rising)
3	CPOL=1, CPHA=1	Setup (Falling)	Sample (Rising)



CST1602B 16-bit Speech Processor

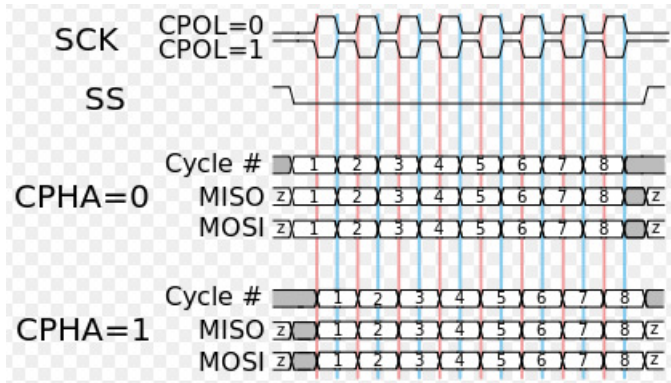

Symbol	Adr	Reset	RW	b15/b7	b14/b6	b13/b5	b12/b4	b11/b3	B10/b2	b9/b1	b8/b0	Description
DATA_W	56H	XX	W	DATA[15:0]								Write Transmission Data Value
DATA_R	56H	XX	R	DATA[15:0]								Read Received Data Value

DATA [15:0]: Transmit/Receive Data Value



CST1602B 16-bit Speech Processor

7.3.2 PortA3 for IR 38KHz Modulation

I/O Port	IR	Direction	Description
PortA.3	IR 38K	O	IR 38K Output

PA3 can provide 38 KHz modulation function. I/O port PA3 combine 38 KHz modulator with register DATA_PA bit 3, this function is enabled by bit11 of system miscellanea register #1. If bit11 of system miscellanea register #1 is set to high, I/O port PA3 will output 38 KHz clock signal when PA3 is configured as output port and DATA_PA bit3 = 1. In contrast, PA3 output low when PA3 is configured as output port and DATA_PA bit3 = 0. The PA3 output pad will be forced to low state.



CST1602B 16-bit Speech Processor

7.3.3 Touch Controller

7.3.3.1 Features

- Touch controller with one dedicated comparator
- Use Real-T counter to count the output pulse width of comparator
- Provides an interrupt for efficient programming.

7.3.3.2 Control Registers

◆ System Miscellanea register #4

Symbol	Adr	Reset	RW	b15/b7	b14/b6	b13/b5	b12/b4	b11/b3	B10/b2	b9/b1	b8/b0	Description
MISC4.L	19H	00	R/W	TOUCH_REALT	TINT_EN	TIS		SVT	THEN	PREC	-	System miscellanea register #4
MISC4.H	19H	00	R/W									

TOUCH_REALT	Touch with Real-T function 0:disable & clear real-T stop flag 1:enable
TINT_EN	Touch INT Enable
TIS	Touch I/O Port input select , 00: NA, 01:PortA, 10:PortB, 11:PortC
SVT	Touch SVT , 0: 1/4*VCC, 1: 1/2*VCC
THEN	Touch Enable
PREC	Touch Pre-charge 1.5V

◆ System Miscellanea register #5

Symbol	Adr	Reset	RW	b15/b7	b14/b6	b13/b5	b12/b4	b11/b3	B10/b2	b9/b1	b8/b0	Description
MISC5.L	18H	00	R/W	THO	LVDO	-	-	-	-	-	-	System Miscellanea register #5

THO	Touch Comparator Output (Read Only)
-----	-------------------------------------

Virtual Programming IO Port

Symbol	Adr	Reset	RW	b15/b7	b14/b6	b13/b5	B12/b4	b11/b3	B10/b2	b9/b1	b8/b0	Description
PA_TOUCH	0EH	00	RW	PA_Touch_EN[3:0]				PortA touch enable bit				
PB_TOUCH	0FH	00	RW	PB_Touch_EN[5:0]				PortB touch enable bit				
PCI_TOUCH.L	10H	00	RW	PC_Touch_EN[7:0]				PortC0~ PortC7 touch enable bit				
PCI_TOUCH.H	10H	00	RW	PI_Touch_EN [1:0]	-	-	-				PortI0~ PortI1 touch enable bit	

If THEN is set high, PA_TOUCH, PB_TOUCH and PCI_TOUCH registers are used to set the corresponding touch enable bit of PortA, PortB, PortC and PortI.



CST1602B 16-bit Speech Processor

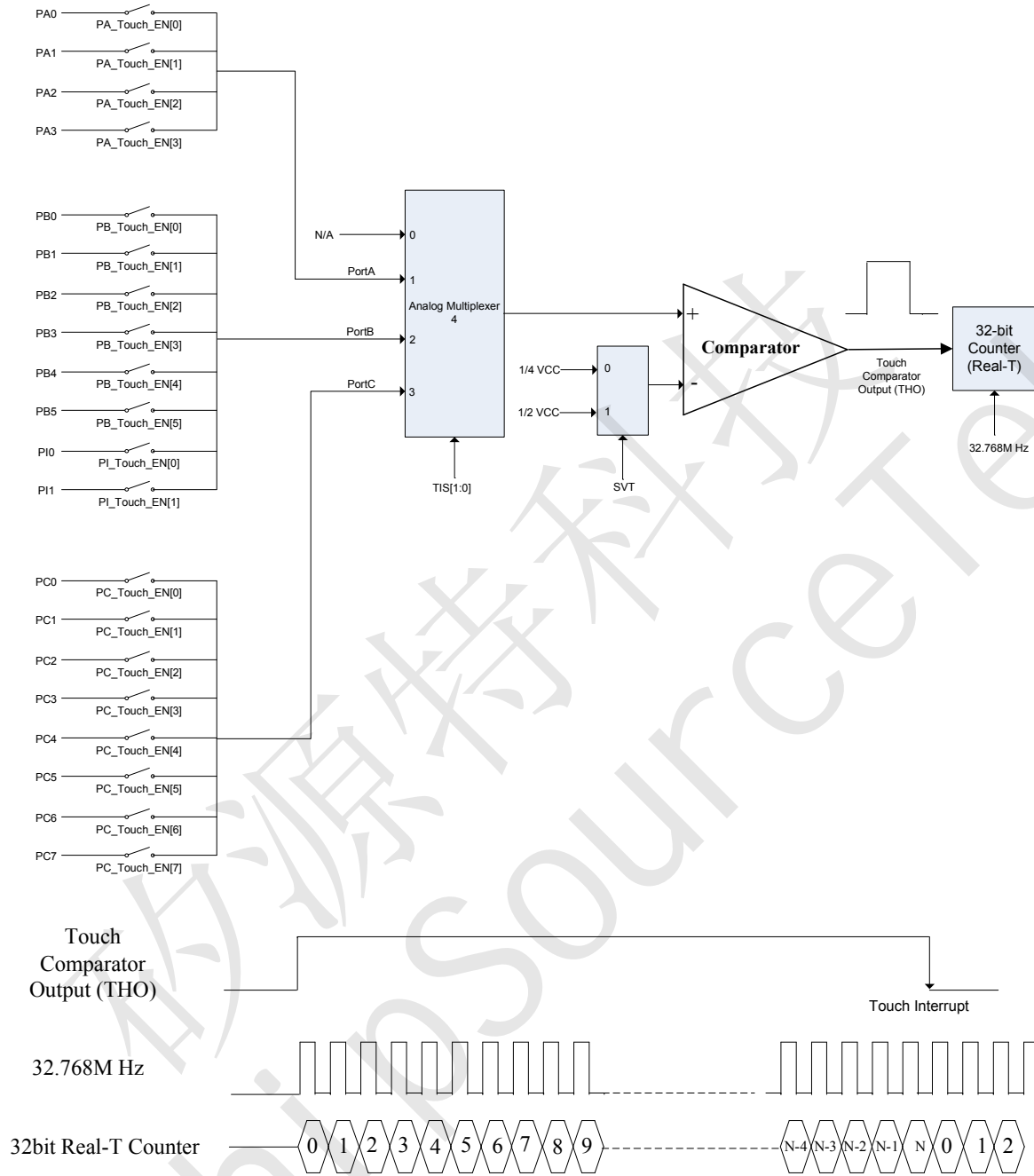

N : pulse width length of touch comparator output(THO)

Figure 7.6 Touch Controller Structure



CST1602B 16-bit Speech Processor

7.4 Audio Output

7.4.1 Mono 16-bit PWM Output

One 16-bit of audio PWM is built-in CST1602B for mono audio application. Mono output pin PWMP and PWMN are connected to speaker directly. This amplifier can be used to direct drive 8 ohm speaker without any external circuit.

Common I/O registers

Symbol	Adr	Reset	RW	b15/b7	b14/b6	B13/b5	b12/b4	b11/b3	b10/b2	b9/b1	b8/b0	Description
Audio-PWM	16H	XX	W	PWM[15:0]								16-bit PWM Channel



CST1602B 16-bit Speech Processor

7.5 Auto-FIFO

The Auto-FIFO allows user transfer base on 4-level of data to Audio-PWM. In some case of frame base applications that data transfer is more efficient than sample base. It is advantageous to decrease number of context switch between main program and interrupt service routine (ISR). The FIFO structure reveal as below:

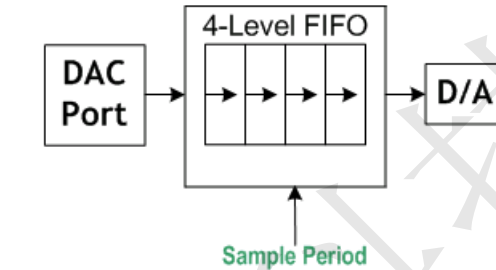

Figure 7.7 Auto FIFO Structure

An interrupt is generated when an entire 4-level FIFO is transfer completed (D/A FIFO buffer is empty), then interrupt service routine should re-load 4-level data to FIFO at ones during 32K or 64K or 128K sample period. The FIFO will automatically shift-out data to Audio-PWM at each sample period.

Note: Auto-FIFO is enable/disable by option setup.



8. CST1602B Flash Control

8.1 Flash Structure

CST1602B is built in 128Kx16 program/data FLASH memory. This Flash is offered with sector endurance of more than 1,000 cycles, Data retention is rated at greater than 10 years. It is suited for convenient and economical updating of program, configuration, or data memory.

The sector architecture is based on sector size of 256 words/512 bytes. The sector erase operation allows the system to erase the device on a sector. The sector architecture is shown as Figure 8.1.

Sector Select(255 sectors)								Word Select(256 words)							
A15	A14	A13	A12	A11	A10	A9	A8	A7	A6	A5	A4	A3	A2	A1	A0

Figure 8.1 The sector architecture

8.2 Flash Sector Erase

The Sector Erase instruction needs to assign erasing sector number to AR register. When “PE = AR” instruction is executed, select of sector will be erased.

Example: Erase 16th sector (0x1000 – 0x10FF)

```
AR = 0x0010 // assign erasing sector number
PE = AR     // sector erasing
```

Note: Erasing time of one sector is 2.6ms.

8.3 Flash Word Programming

CST1602B provide one word programming instruction. The Word Programming instruction needs to assign programming data to AR register and assign programming address to P0/P1 register. When “PM[P0/P1] = AR” instruction is executed, select of flash address will be programmed.

Example: Program 16th word address (0x0010)

```
P0.hh = 0x0000
P0 = 0x0010 // assign programming address
AR = 0x5678 // assign programming data
PM[P0] = AR // word programming
```

Note: Programming time of one word is 41us.



CST1602B 16-bit Speech Processor

8.4 Flash Word Read

CST1602B provide word read instruction. The Word Read instruction needs to assign reading address to P0/P1 register. When “AR = PM[P0/P1]” instruction is executed, select of word will be read out to AR register.

Example: Read 16th word address (0x0010)

P0.hh = 0x0000

P0 = 0x0010 // assign reading address

AR = PM[P0] // read word data

Note: Reading time of one word is two cycles of System Clock.

8.5 Flash unlock/lock for Programming/Erase instruction

Flash unlock instruction need to be executed before flash programming/erase instruction will be executed. This flash unlock instruction is to ensure the safety of the flash operation in order to prevent flash data from being modified by mistake. After the Flash program/erase instruction is executed, the Flash lock instruction needs to be executed to ensure the flash security.

Example1: Flash unlock

ENC_DAT EQU 54H

ar = 0xdb3f

io[ENC_DAT] = ar

ar = 0x8a17

io[ENC_DAT] = ar

Example2: Flash lock

ENC_DAT EQU 54H

ar = 0x1234

io[ENC_DAT] = ar

ar = 0x5678

io[ENC_DAT] = ar



CST1602B 16-bit Speech Processor

9. CST1602B Others

9.1 Dynamic System Clock

Operation frequency can be adjusted by software dynamically. User can adjust operation frequency in order to reduce power consumption.

Write Data	CPU Operation frequency
3	6 MHz
4	8 MHz
5	11 MHz
6	12 MHz
7	13 MHz

Example: Change CPU Operation frequency to 6MHz.

```
SPEED EQU 67H
```

```
ar = 0x0003;  
io[SPEED] = ar;
```



CST1602B 16-bit Speech Processor

9.2 Low Voltage Detector

The voltage detect range of LVD is 1.8V ~ 2.98V for D2ENB = 0 or 2.7V~4.47V for D2ENB=1. When $VCC/2$ or $VCC/3 < VBGI$, LVDO=1, otherwise LVDO=0.

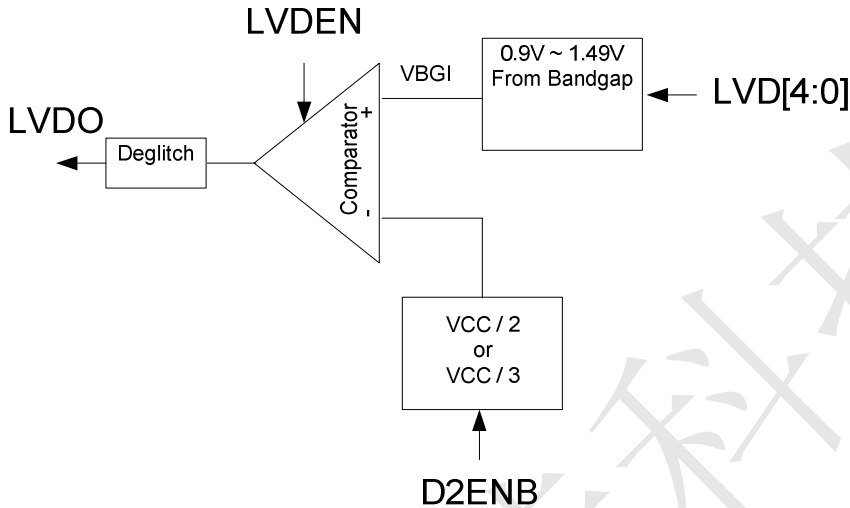

Fig 9.2-1 Function diagram of LVD

Register	MISC3.b6	MISC3.b7	MISC3.b8~12	MISC5.b6
Control signal	LV DEN	D2ENB	LVD[4:0]	LVDO

LVD [4:0]	D2ENB=0		D2ENB=1		LVD [4:0]	D2ENB=0		D2ENB=1	
	Ideal	Real	Ideal	Real		Ideal	Real	Ideal	Real
0x00	1.80	1.79	2.70	2.68	0x10	2.44	2.40	3.66	3.59
0x01	1.84	1.83	2.76	2.74	0x11	2.48	2.44	3.72	3.65
0x02	1.88	1.87	2.82	2.79	0x12	2.52	2.48	3.78	3.70
0x03	1.92	1.91	2.88	2.85	0x13	2.56	2.52	3.84	3.76
0x04	1.96	1.95	2.94	2.91	0x14	2.60	2.56	3.90	3.82
0x05	2.00	1.98	3.00	2.96	0x15	2.64	2.59	3.96	3.87
0x06	2.04	2.02	3.06	3.02	0x16	2.68	2.63	4.02	3.93
0x07	2.08	2.06	3.12	3.08	0x17	2.72	2.67	4.08	3.99
0x08	2.12	2.10	3.18	3.13	0x18	2.76	2.71	4.14	4.05
0x09	2.16	2.14	3.24	3.19	0x19	2.80	2.75	4.20	4.10
0x0A	2.20	2.18	3.30	3.25	0x1A	2.84	2.79	4.26	4.16
0x0B	2.24	2.21	3.36	3.30	0x1B	2.88	2.82	4.32	4.22
0x0C	2.28	2.25	3.42	3.36	0x1C	2.92	2.86	4.38	4.27
0x0D	2.32	2.29	3.48	3.42	0x1D	2.96	2.90	4.44	4.33
0x0E	2.36	2.33	3.54	3.48	0x1E	3.00	2.94	4.50	4.39
0x0F	2.40	2.37	3.60	3.53	0x1F	3.04	2.98	4.56	4.44

It's a COB test result for reference only.



CST1602B 16-bit Speech Processor

10. CST1602B System Control

10.1 Halt Mode & Wake up

CST1602B is changed into HALT mode (system clock stop, RTC stop by Option setup) when HALT instruction executed. It provides a power saving mode for those applications requiring a very low stand-by current. The RTC timer, PA0~PA3, PB0~PB5 and PC0~PC7 are supporting the wake-up MCU function when related I/O port raising/falling edge which selects by program. The program counter will be 04H when HALT instruction executed immediately; in addition, when wake up condition is occurred, MCU will release HALT state and program counter go-to next address after difference stable clock is delayed by option. During the Halt mode period, the SRAM will keep their previous data without changing.

10.2 Watch Dog Timer Reset (WDT)

Symbol	Adr	Reset	RW	b15/b7	b14/b6	b13/b5	b12/b4	B11/b3	b10/b2	b9/b1	b8/b0	Description
ClrWDT	1DH	XX	W									Clear WDT

The watch dog timer (WDT) is used to reset whole chip when detect unexpected execution sequence of instructions caused by accident condition, avoiding dead lock of MCU program. Software shall run an "clear watch dog timer"(CLRWDT) instruction before this timer time out. It will generate a reset signal to reset whole system when WDT overflow.

WDT will be reset when wake-up from halt or after power on or software clear. In test mode, watch dog timer will be disabled no matter watch-dog-timer is time-out or not.

The reset watch dog timer code syntax is strongly recommended as: "**CLRWDT = AR**".

10.3 Low Voltage Reset

When VCC power is applied to the chip, the low voltage reset is initially enabled by default, it will be disabled when in halt mode. The internal system reset will be generated if VCC power below the voltage of LVR(option setup). The normal operation of LVR is always enable expect disable in HALT mode.

10.4 Reset System

CST1602B reset is come from four signals which are power on reset, low voltage reset(LVR), external IO PB3 or PC3 pin (by option) and WDT overflow reset, as shown in Figure 10.1. A dedicated external resetb input pin (by option) is provided to reset this chip, which has 30K ohm pull up resistor. The operation frequency of MCU will go back to BANK0 mode when reset occurred.



CST1602B 16-bit Speech Processor

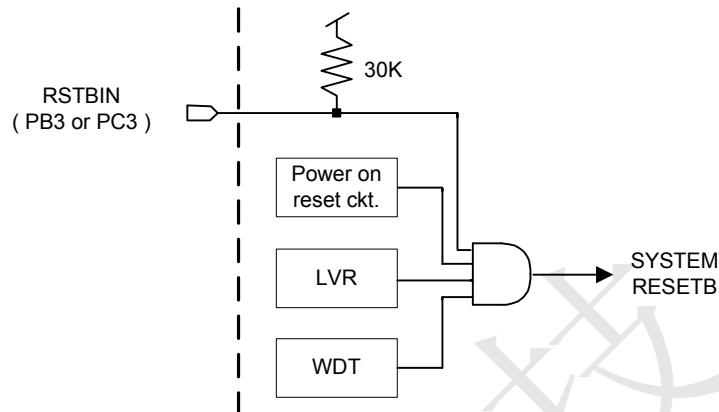

Figure 10.1 Reset system block diagram

10.5 Clock System Architecture

CST1602B clock system supports internal ROSC(65.536MHz) for System Clock, and Low power RC oscillator(32768Hz [-5%@2.0V](#) ~ +15%@5.0V) for RTC function.

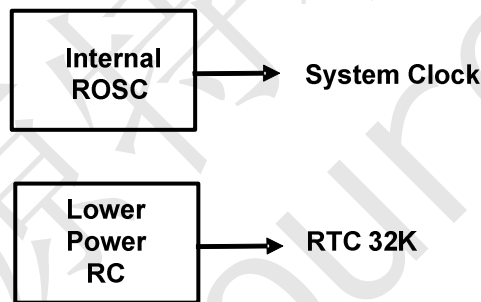

Figure 10.2 Clock System Diagram



CST1602B 16-bit Speech Processor

10.6 Ultra Deep Sleep

- Ultra deep sleep mode only support PortA0~ PortA3 rising edge wake up
- Ultra deep sleep mode only supports execution in bank0
- All power off except necessary in Ultra deep sleep mode
- Typical standby current below 2uA in Ultra deep sleep mode
- Keep all I/O status in Ultra deep sleep mode

10.6.1 Control Registers

Virtual Programming IO Port

Symbol	Adr	Reset	RW	b15/b7	b14/b6	b13/b5	B12/b4	b11/b3	b10/b2	b9/b1	b8/b0	Description
DEEP_SLEEP2.L	1FH	04	R/W	-	-	-	-	-	VDD1EN	CLK	DSENIN	Deep Sleep2 Status Register[7:0]
DEEP_SLEEP2.H	1FH	00	R/W	DSENO	-	-	-	-	WAKE[3:0]			Deep Sleep2 Status Register[15:8]

DSENIN	Ultra deep sleep input enable
CLK	Clock pulse generator
VDD1EN	1: Internal power on 0: Internal power off
WAKE	Default:0, Wake Up Enable Bit0: PortA0 wake up enable bit Bit1: PortA1 wake up enable bit Bit2: PortA2 wake up enable bit Bit3: PortA3 wake up enable bit Note: At least one wake up enable bit must be enabled.
DSENO	Ultra deep sleep wake up flag, 1: wake up from Ultra deep sleep mode occurred

Notice: Ultra deep sleep mode is invalid in ICE debug mode.



CST1602B 16-bit Speech Processor

10.6.2 Flow Chart

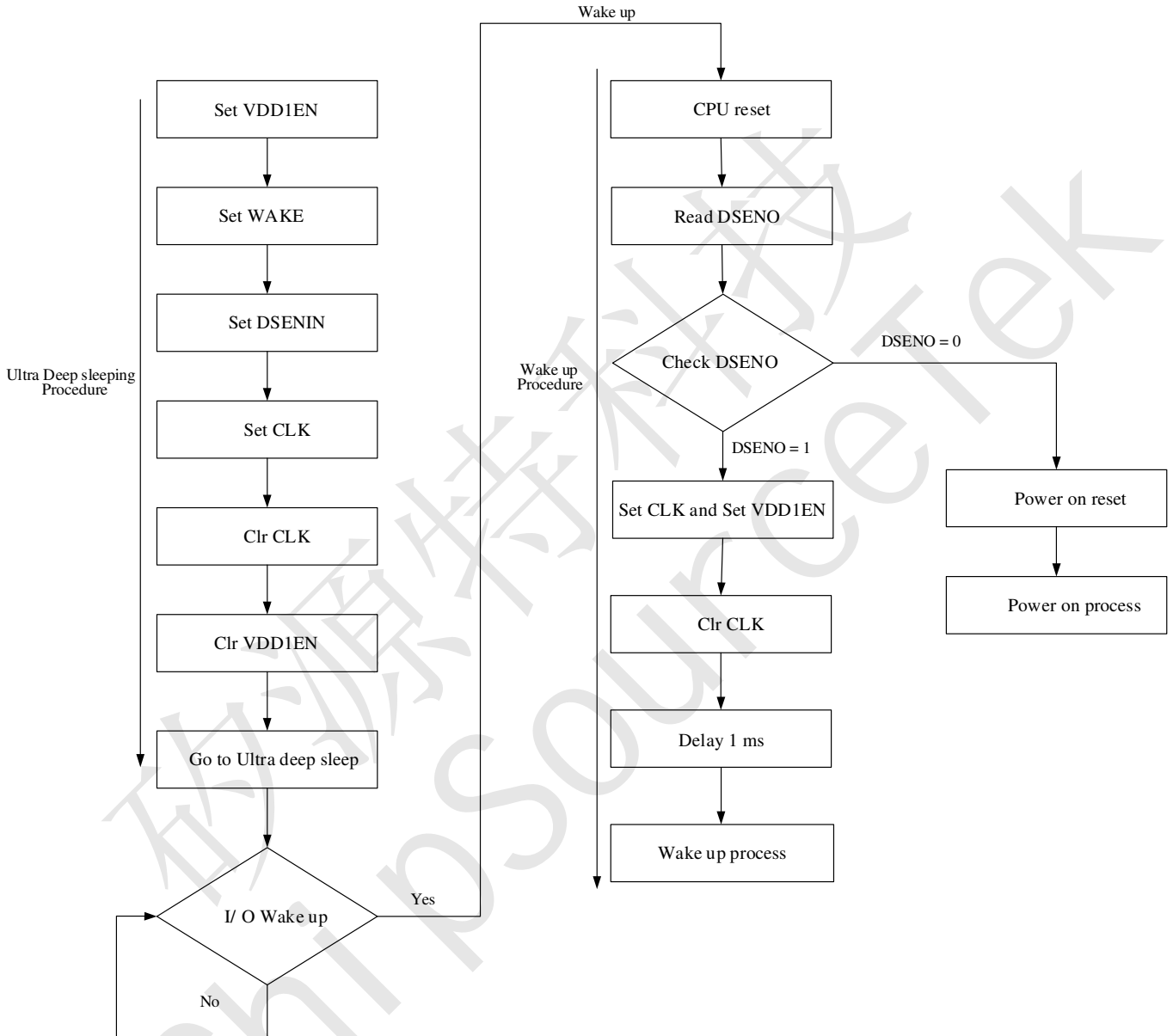



CST1602B 16-bit Speech Processor

10.6.3 Example Code

Ultra_deep_sleep_procedure:

```
ax = 0 // initial value

ar = IOP_DEEP_SLEEP2
IO[IOP_IX] = ar
set ax.b2 // Internal power on
ar = ax
IO[IOP_DAT] = ar

ar = IOP_DEEP_SLEEP2
IO[IOP_IX] = ar
set ax.b8 // PortA0 wake up enable
ar = ax
IO[IOP_DAT] = ar

ar = IOP_DEEP_SLEEP2
IO[IOP_IX] = ar
set ax.b0 // Ultra deep sleep input enable
ar = ax
IO[IOP_DAT] = ar

ar = IOP_DEEP_SLEEP2
IO[IOP_IX] = ar
set ax.b1 // Generate clock pulse high
ar = ax
IO[IOP_DAT] = ar

ar = IOP_DEEP_SLEEP2
IO[IOP_IX] = ar
clr ax.b1 // Generate clock pulse low
```



CST1602B 16-bit Speech Processor

ar = ax

IO[IOP_DAT] = ar

ar = IOP_DEEP_SLEEP2

IO[IOP_IX] = ar

clr ax.b2 // Internal power off

ar = ax

IO[IOP_DAT] = ar

矽源特科技
ChipSourceTek



CST1602B 16-bit Speech Processor

Wake_up_procedure:

```
ar          = IOP_DEEP_SLEEP2
IO[IOP_IX]  = ar

ar = IO[IOP_DAT]
test ar.b15                                // Read Ultra deep sleep wake up flag DSENO
if nz jmp  wake_up_from_ultra_deep_sleep
jmp         power_on_reset                 // Run power on process
```

wake_up_from_ultra_deep_sleep:

```
ax = 0                                     // initial value

ar          = IOP_DEEP_SLEEP2
IO[IOP_IX]  = ar
set ax.b1   // Generate clock pulse high
set ax.b2   // Internal power on
ar= ax
IO[IOP_DAT] = ar

ar          = IOP_DEEP_SLEEP2
IO[IOP_IX]  = ar
clr ax.b1   // Generate clock pulse low
ar =ax
IO[IOP_DAT] = ar
```

Call delay_1ms

Call wake_up_process



CST1602B 16-bit Speech Processor

11. CST1602B Electrical Characteristics

11.1 Absolute Maximum Rating

DC Supply Voltage	VCC	<5.5	V
Input Voltage	Vin	-0.5 to VCC+0.5	V
Operating Temperature Range	Ta	-20 to 75	
Storage Temperature Range	Tstg	-50 to 150	

11.2 DC/AC Characteristics

VCC=3.0V, Ta=25°C unless otherwise noted

Operating voltage	VCC	1.8 V	-	5.5 V	
Operating frequency (BANK0)	Fbank0	6.553MHz ±3%		13.107MHz ±3%	
RC oscillator frequency	Frc1		65.536MHz ±3%		
Low power RC oscillator frequency	Frc2	32768Hz -30%		32768Hz +30%	
Normal Sleep Halt Current	Ihalt1		5uA	9uA	All function off
Ultra Deep Sleep Halt Current	Ihalt2		2uA	3uA	VDD power off
Operating Current	Iop		5mA		no load
input high voltage (PortA, PortB, PortC)	VIH	0.6 VCC			Without schmitt trigger
input low voltage (PortA, PortB, PortC)	VIL			0.5 VCC	Without schmitt trigger
input high voltage (PortI)	VIH	0.7 VCC			With schmitt trigger
input low voltage (PortI)	VIL			0.3 VCC	With schmitt trigger
output high voltage	Voh	0.95 VCC			no load
output low voltage	Vol			0.05 V	no load
output high current	Ioh		16 mA		Vout=VCC-0.4V, PortA, B, C, I select strength driving option
output low current	Iol		-16 mA		Vout=0.4V PortA, B, C, I select strength driving option
pull-down resistance	Rpd		50K/220K/ 1M ohm		pins with pull-down, Port A,B,C, I
PWM driving current			350 mA		VPD=5.0V
PWM sink current			400 mA		VPD=5.0V



CST1602B 16-bit Speech Processor

12. CST1602B Application Circuit and Chip Power Circuit

Application Circuit: Mono16-bit PWM output

Notice:

1. VCC Decoupling Cap 10uF should be close to IC within 0.5cm.
2. VCC Decoupling Cap 0.1uF should be close to IC within 0.5cm.

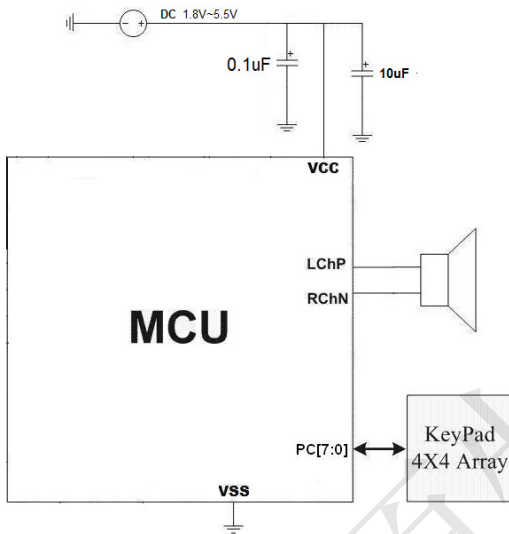



CST1602B 16-bit Speech Processor

13. CST1602B Appendix:

Appendix 1: PORT A PIN MAP RELATE TO FUNCTION

	PORT A[3:0]			
	3	2	1	0
SPI (Master)				
ICE				
IR 38K	IR_38KO			
EXT-RESETB				
EXT-INT		EXT_INT1	EXT_INT0	

Appendix 2: PORT B PIN MAP RELATE TO FUNCTION

	PORT B[5:0]					
	5	4	3	2	1	0
SPI (Master)	CS			SO(in)	SI(out)	CLK
ICE						
IR 38K						
EXT-RESETB			EXT-RSTB(0)			
EXT-INT						

Appendix 3: PORT C PIN MAP RELATE TO FUNCTION

	PORT C[7:0]							
	7	6	5	4	3	2	1	0
SPI (Master)								
ICE								
IR 38K								
EXT-RESETB					EXT-RSTB(1)			
EXT-INT								



CST1602B 16-bit Speech Processor

Appendix 4: PORT I PIN MAP RELATE TO FUNCTION

	PORT I[1:0]	
	1	0
SPI (Master)		
ICE	ICE_SCLK(I)	ICE_SD(I/O)
IR 38K		
EXT-RESETB		
EXT-INT		



CST1602B 16-bit Speech Processor

14. CST1602B Package: SOP8 / SOP16 / SSOP24 / SOP16-2

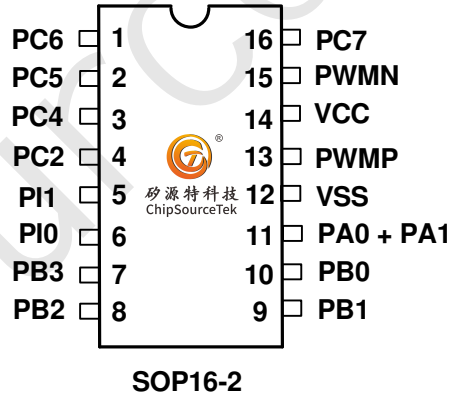
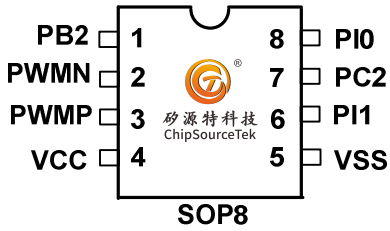



CST1602B 16-bit Speech Processor

PACKAGE INFORMATION

SOP08

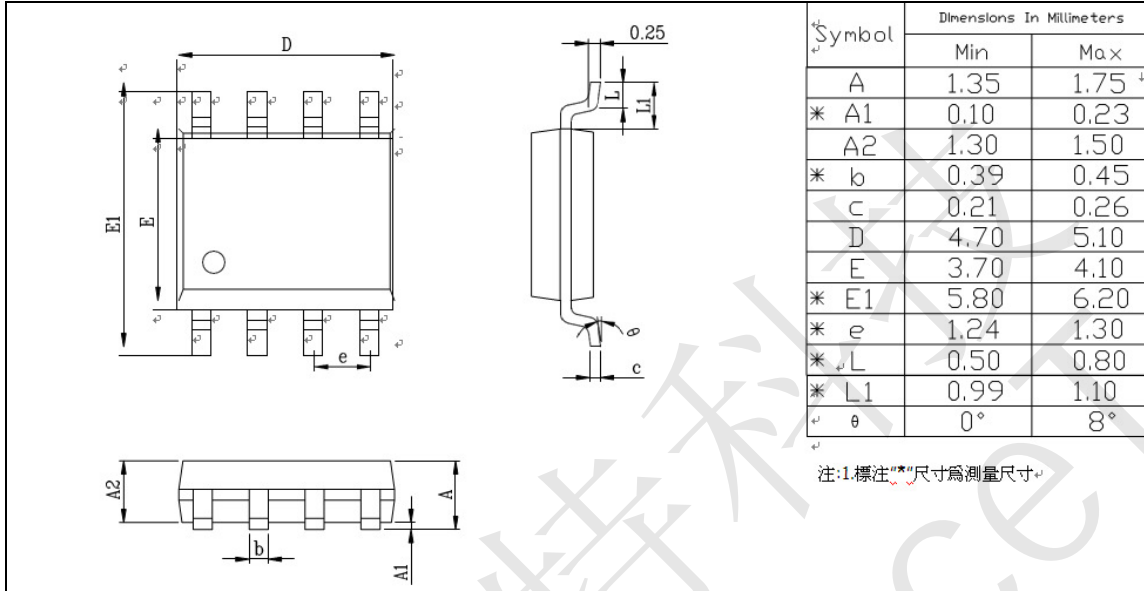

SOP14

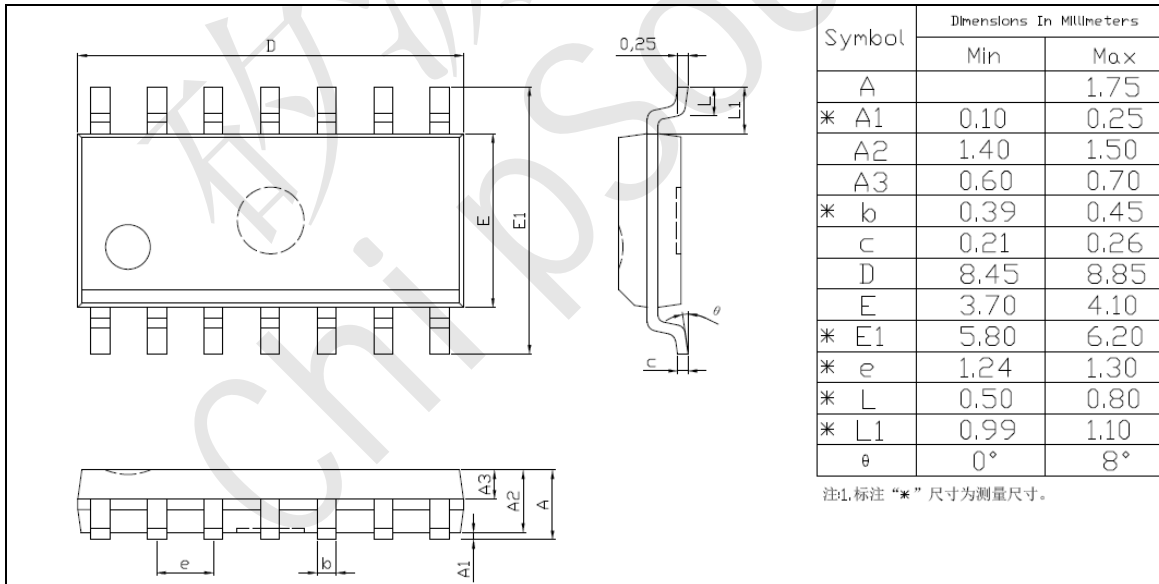



CST1602B 16-bit Speech Processor

SOP16

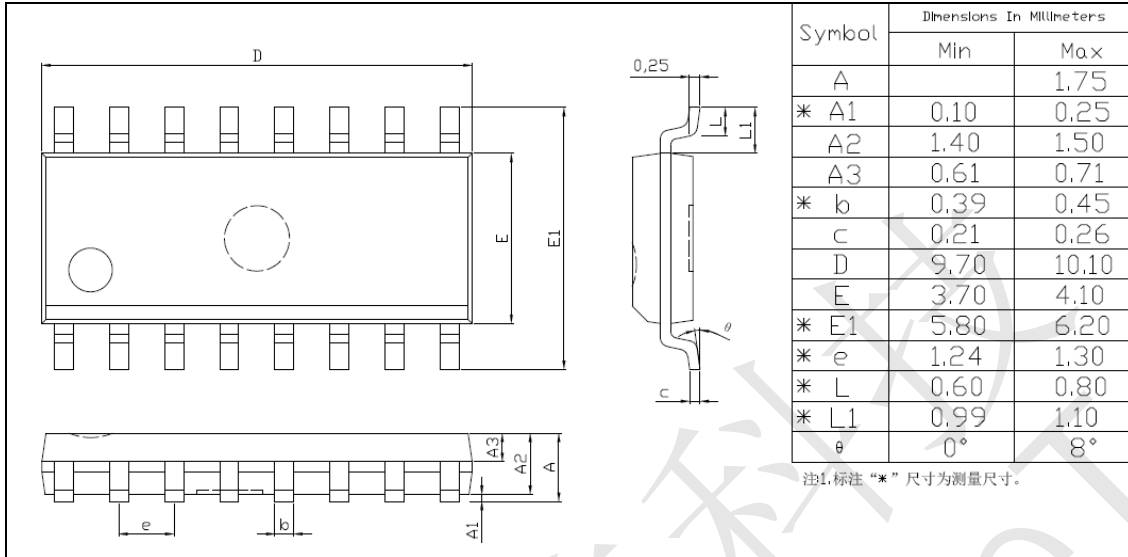

SSOP24

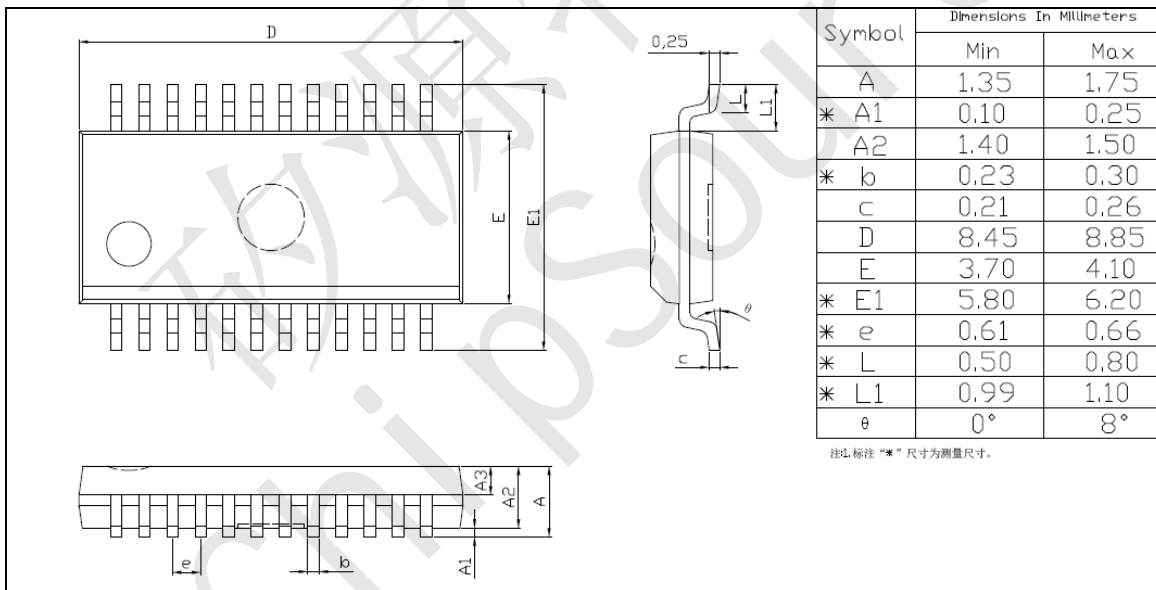



CST1602B 16-bit Speech Processor

SSOP28

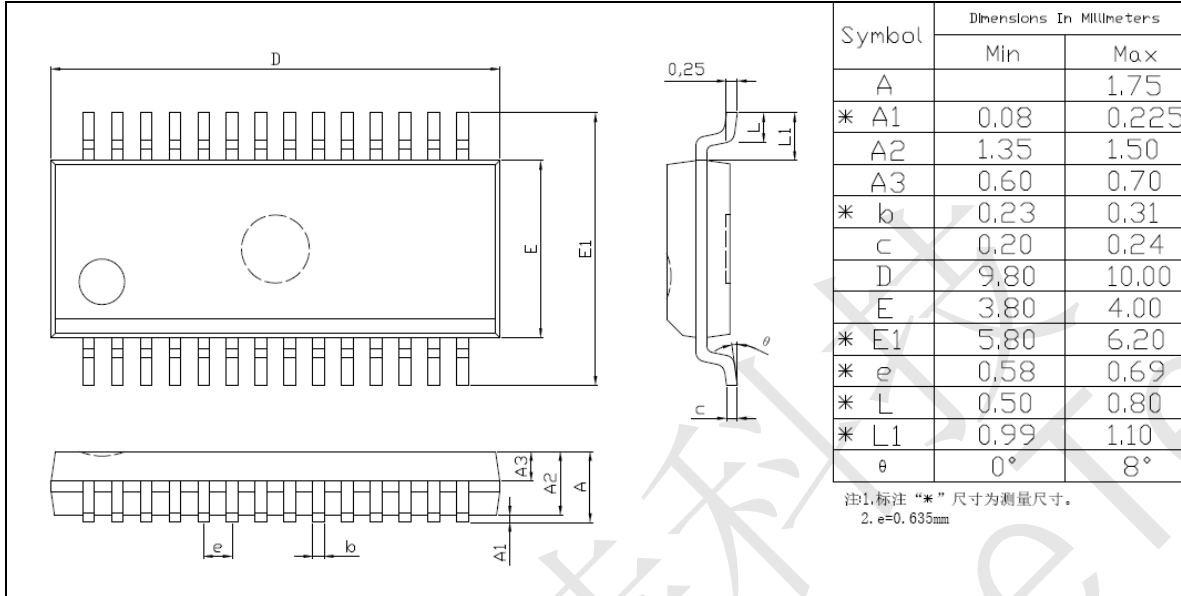



CST1602B 16-bit Speech Processor

15. CST1602B SPI Operation Sequence

A1.0 Initial Process

```
set io[IOC_PB].b5 // set output port
set io[STATUS].b8 // Enable SPI Control

set io[PortB].b5 // CS=1
ar = io[SPI_CTRL]
set ar.b11 // set ICS = 1
io[SPI_CTRL] = ar
```

A1.1 Sending Data Process

```
clr io[PortB].b5 // CS = 0
ar = io[SPI_CTRL]
clr ar.b11 // ICS = 0
io[SPI_CTRL] = ar
```

SPI_write_data:

```
ar = data
io[SPI_DATA] = ar; // write data

ar = 0x12; // set total byte number & send data
ah = 0x10; // speed 16M
io[SPI_CTRL] = ar; //set SEND = 1;
call Check_Tran_OK

set io[PortB].b5 // CS = 1
ar = io[SPI_CTRL]
set ar.b11 // ICS = 1
io[SPI_CTRL] = ar
```

Check_Tran_OK:

```
ar = io[SPI_CTRL]
test ar.b7
if eq jmp Check_Tran_OK
```

Check_Tran_OK_End:

```
rets
```



CST1602B 16-bit Speech Processor

A1.2 Receiving Data Process

```
clr io[PortB].b5          // CS =0
ar = io[SPI_CTRL]
clr ar.b11                // ICS = 0
io[SPI_CTRL] = ar
```

SPI_read_data:

```
ar = 0x22;                // set total byte number & receive data
ah = 0x10;                // speed 16M
io[SPI_CTRL] = ar;        //set RCV = 1;
call Check_Tran_OK
ar = io[SPI_DATA];        // read data

set io[PortB].b5          // CS =1
ar = io[SPI_CTRL]
set ar.b11                // ICS = 1
io[SPI_CTRL] = ar
```

Check_Tran_OK:

```
ar = io[SPI_CTRL]
test ar.b7
if eq jmp Check_Tran_OK
```

Check_Tran_OK_End:

```
rets
```



CST1602B 16-bit Speech Processor

16. CST1602B Revision history

REVISION	DESCRIPTION	PAGE	DATE
V1.0	New establish		2022/3/30

矽源特科技
ChipSourceTek